

# *XPJ-661UF*

## Operation Manual

Operations and Maintenance Methods

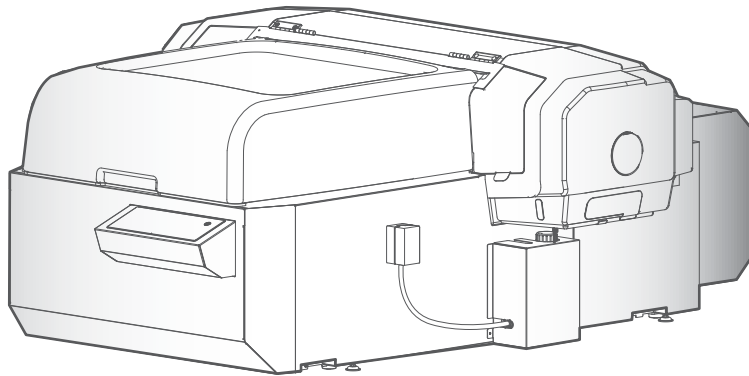

- 
- Unauthorized copying or duplication of the whole or part of the contents of this manual is prohibited.
  - Every care has been taken in writing the contents of this manual, but please contact MUTOH or the dealer you purchased the product from if you find any unclear, erroneous or otherwise unsatisfactory content in the manual.
  - Please be aware that MUTOH will not be liable in any way for failures or accidents that result from handling or operating the printer according to any procedures other than those set forth in this manual.
  - Company names and product names that appear in this manual are registered trademarks of the respective companies.

## For Users in Europe



The CE marking is a mandatory European marking for certain product groups to indicate conformity with the essential health and safety requirements set out in European Directives.

By affixing the CE marking, the manufacturer, his authorized representative, or the person placing the product on the market or putting it into service ensures that the item meets all the essential requirements of all applicable EU directives and that the applicable conformity assessment procedures have been applied.

## For Users in the United States

This equipment has been tested and found to comply with the limits for a Class A digital device, pursuant to Part 15 of the FCC Rules.

These limits are designed to provide reasonable protection against harmful interference when the equipment is operated in a commercial environment.

This equipment generates, uses, and can radiate radio frequency energy and, if not installed and used in accordance with the instruction manual, may cause harmful interference to radio communications.

Operation of this equipment in a residential area is likely to cause harmful interference in which case the user will be required to correct the interference at his own expense.

This system (including the housing and safety device) is a Class 1 laser product.

Laser specifications of this system (including the housing)

Wavelength: 655 nm, maximum output: 390mW or less, pulse duration: 3.0 $\mu$ s

Complies with IEC 60825-1 Edition 3.0 (2014-05-15).

Complies with FDA performance standards for laser products except for deviations pursuant to Laser notice No.56 dated May 8, 2019.

### **CAUTION**

Use of controls or adjustments or performance of procedures other than those specified herein may result in radiation exposure.

## CHAPTER 1 BASIC OPERATIONS

<b>Introduction</b> .....	<b>8</b>
Main components of your printer .....	8
System configurations of this product.....	12
Displaying the Printing Preferences screen of printer driver .....	14
Launching/Displaying/Exiting MUTOH Status Monitor (MSM) .....	15
Launching MUTOH LFP Finder .....	16
Launching Layout and Print Tool 2 .....	16
Launching MUTOH Layer Editor.....	16
Displaying Help .....	17
Requirements for usable media .....	18
Table Dimensions & Diagrams .....	20
Precautions when using this product.....	21
<b>Powering ON / OFF</b> .....	<b>24</b>
Turning the power ON.....	24
Turning the power OFF .....	24
If not using the printer for a long time.....	26
<b>Sleep Mode</b> .....	<b>30</b>
<b>Printing</b> .....	<b>32</b>
Printing area .....	32
Loading media .....	33
Nozzle check and cleaning.....	38
Starting printing.....	41
Pausing/Restarting printing.....	44
Canceling printing.....	44
Menus you can access while printing .....	45
Checking the printing area.....	49
Applying additional UV light after printing .....	54
Calibrating table height .....	55
Layer printing .....	56

## CHAPTER 2 ADVANCED OPERATIONS

<b>Introduction</b> .....	<b>58</b>
Operating the keys to use the menus.....	58
Panel setup menu .....	60
<b>Menu1: Setup</b> .....	<b>63</b>
Setup 1: User Type.....	63
Setup 2: Advanced .....	79
Setup 3: Initial Settings .....	89

Setup 4: Initialization .....	92
<b>Menu2: Test Print .....</b>	<b>93</b>
Test Print 1: Nozzle Check .....	93
Test Print 2: Nozzle Check B. ....	93
Test Print 3: Mode Print. ....	94
Test Print 4: Setup List .....	94
Test Print 5: Palette .....	95
<b>Menu3: Maintenance .....</b>	<b>96</b>
Maintenance 1: Cleaning .....	96
Maintenance 2: Reset Waste Ink .....	97
Maintenance 3: CR Maintenance .....	97
Maintenance 4: UV Scan .....	97
Maintenance 5: Ink Discharge .....	98
Maintenance 6: Plug Life .....	99
Maintenance 7: Calibration .....	100
Maintenance 8: Moving Printer .....	100
Maintenance 9: Table Maintenance .....	100
Maintenance 10: Daily Maintenance .....	101
<b>Menu4: Printer Status .....</b>	<b>102</b>
Printer Status 1: Ink .....	102
Printer Status 2: Lifetimes .....	103
Printer Status 3: Job Status .....	104
Printer Status 4: Version .....	104
Printer Status 5: Serial No. ....	104
Printer Status 6: Total Print Area .....	105
<b>Menu5: Option .....</b>	<b>106</b>
Option 1: Rotary Unit .....	106
<b>Menu6: Sleep Mode .....</b>	<b>107</b>
Sleep Mode1: Start .....	107
Sleep Mode2: Cleaning Timer .....	107
<b>Menu chart .....</b>	<b>108</b>
Setting menu 1 .....	108
Setting menu 2 .....	109
Setting menu 3 .....	110
Setting menu 4 .....	111
Menu during printing .....	111

## CHAPTER 3 MAINTENANCE

<b>Maintenance .....</b>	<b>114</b>
<b>Wearing the protective equipment .....</b>	<b>115</b>

How to wear the supplied gloves .....	115
<b>Agitating ink.....</b>	<b>116</b>
Agitating ink .....	116
<b>Checking ink level and replacing ink.....</b>	<b>119</b>
Checking ink level .....	119
When ink needs to be replaced soon .....	119
Replacing ink.....	120
Replacing Adapter's plug for high capacity ink pack adapter .....	123
<b>Emptying waste ink tank .....</b>	<b>124</b>
Emptying waste ink tank.....	124
<b>Daily Maintenance .....</b>	<b>128</b>
Flow of Daily Maintenance.....	128
Preparing for Daily Maintenance .....	129
Performing Daily Maintenance.....	131
<b>Printer Maintenance .....</b>	<b>137</b>
Head cleaning.....	137
Clean daily maintenance parts .....	139
Inside cleaning .....	142
<b>Replacing consumable parts .....</b>	<b>147</b>
Replacing absorption material for the flushing box .....	147
Replacing the cleaning wiper .....	151
Replacing the Emitting Window Glass on the UV-LED Lamp.....	154
Replacing UV-LED Lamp Filter .....	157
<b>Moving and Transporting.....</b>	<b>160</b>
Moving the printer .....	160
Transporting .....	161
How to perform initial ink charging after ink discharge .....	168

## CHAPTER 4 APPENDIX

<b>Messages and Error Messages.....</b>	<b>172</b>
Status messages.....	172
Error message display and possible solutions.....	173
Error requiring restart.....	176
<b>Troubleshooting .....</b>	<b>177</b>
Installation and initial setup troubleshooting.....	177
Boot-up troubleshooting .....	178
Media-related troubleshooting .....	178

Table-related troubleshooting .....	179
Printing-related troubleshooting .....	180
<b>Specifications of this product .....</b>	<b>183</b>
List of specifications .....	183
<b>Options / Supply list .....</b>	<b>185</b>
<b>Revision History .....</b>	<b>185</b>

# Chapter 1 Basic Operations

Introduction .....	8
Main components of your printer .....	8
System configurations of this product .....	12
Displaying the Printing Preferences screen of printer driver .....	14
Launching/Displaying/Exiting MUTOH Status Monitor (MSM) .....	15
Launching MUTOH LFP Finder .....	16
Launching Layout and Print Tool 2 .....	16
Launching MUTOH Layer Editor .....	16
Displaying Help .....	17
Requirements for usable media .....	18
Table Dimensions & Diagrams .....	20
Precautions when using this product .....	21
Powering ON / OFF .....	24
Turning the power ON .....	24
Turning the power OFF .....	24
If not using the printer for a long time .....	26
Sleep Mode .....	30
Printing .....	32
Printing area .....	32
Loading media .....	33
Nozzle check and cleaning .....	38
Starting printing .....	41
Pausing/Restarting printing .....	44
Canceling printing .....	44
Menus you can access while printing .....	45
Checking the printing area .....	49
Applying additional UV light after printing .....	54
Calibrating table height .....	55
Layer printing .....	56

# Introduction

## Main components of your printer

### Front side

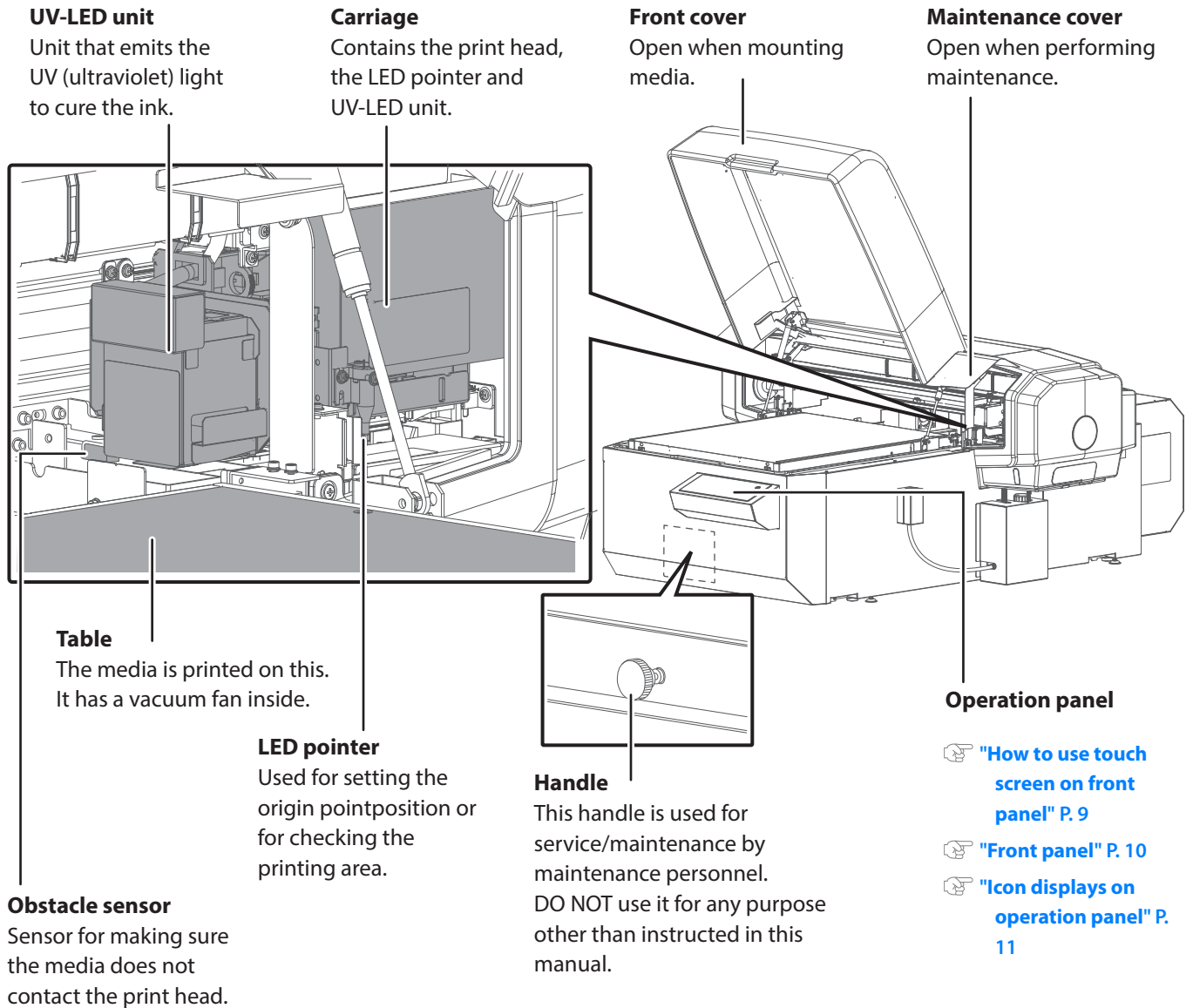



## Rear side

---

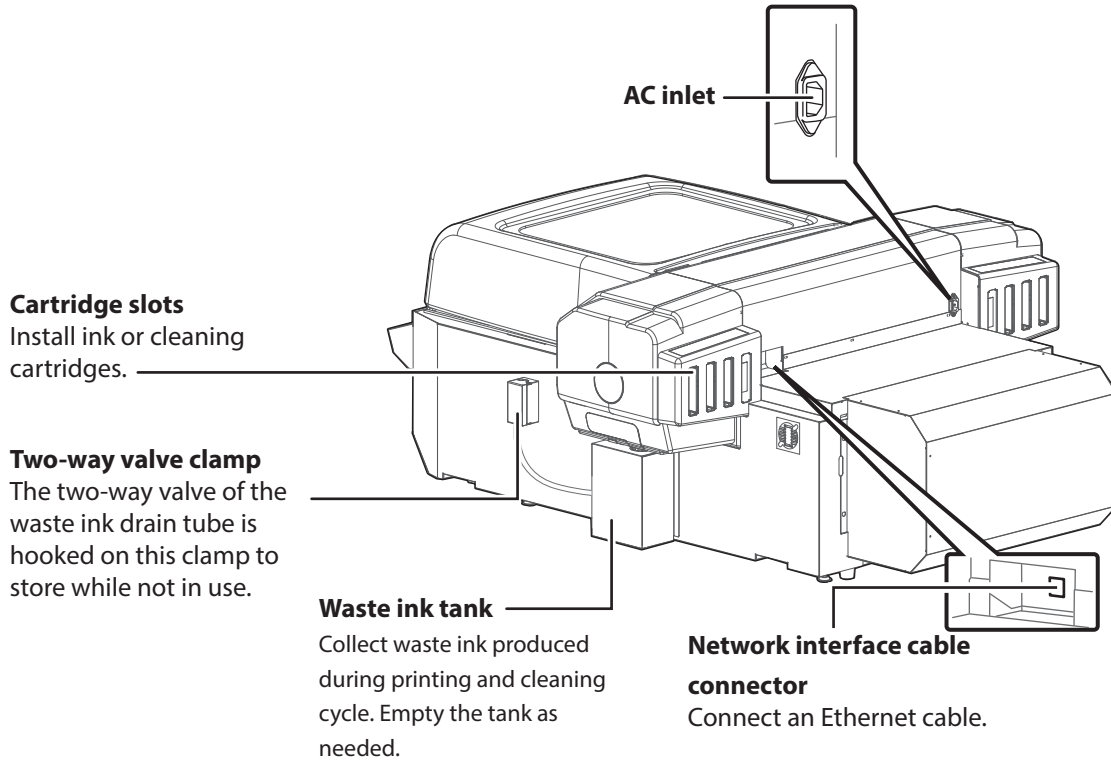

## How to use touch screen on front panel

---

The printer has a touch-screen panel located on the front right of the printer. The active keys are lit up on the panel for guidance.

- Tap: Lightly touch the key with your finger, then immediately release.
- Long-touch: Keep touching the key.

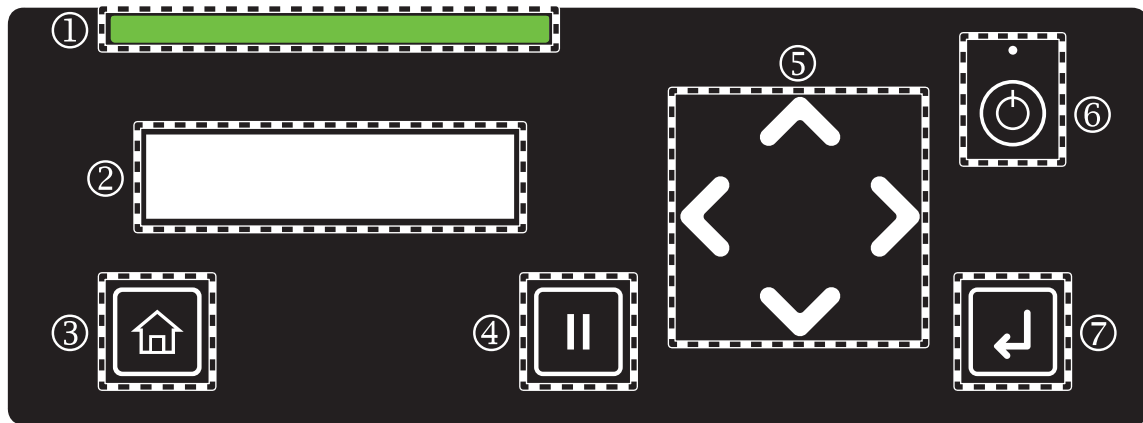

- 1 Status Bar

Indicates the printer status by LED light.

  - Working normally: Solid green or flashing green
  - Error/Alert state: Solid red (error) or flashing red (alert)
  
- 2 Display

Displays the printer status, setting menu, errors and so on.
  
- 3



[Home] key:  
Access to or exit the menu.
  
- 4







[Cancel] key:





  - Pause the print job. While pausing, tap the key again to resume printing.
  - While the printer is not printing, tap the key to cut the media.
  
- 5



Arrow keys:  
When you have entered the setup menu, the arrow keys are used to select a menu or enter a value.

  -  key: Go to the previous item.
  -  key: Return to the upper level menu without saving the change.
  -  key: Go to the sub menu.
  -  key: Go to the next item.

While the printer is in standby mode, it is used to load media, remove media, run a nozzle check, or perform head cleaning.

  -  key: Tap after loading media to put the printer into ready-to-print status.
  -  key: Tap to run a nozzle check.
  -  key: Tap to perform cleaning.
  -  key: Tap after printing to remove media from the table.
  
- 6



[Power] button:

  - Long press to power on the printer.
  - While the power is on, long press the button to power off the printer.

 **Note**

The  symbol means “standby”. Even the Power LED turns off, the device still consumes some power unless the power cords are disconnected. This state is referred to as the power being “off” in this Manual.

When the power cord is plugged in, the small LED light above the Power button turns on.
  
- 7



[Enter] key:  
Use the Enter key to select a menu or confirm a value.

## Icon displays on operation panel

Icons to indicate the status of the ink or cartridges are displayed in the following situations:

- When no menu is displayed
- When there is an ink or cartridge error

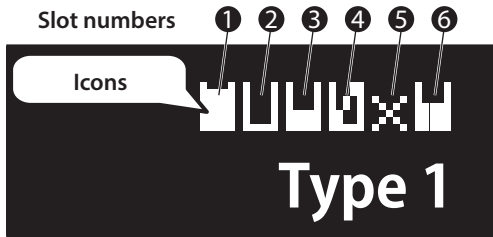

- Each indicator corresponds to the cartridge slots from Slot 1 through Slot 6. The leftmost indicator represents the ink level of the cartridge in Slot 1.
- In the display shown on the left, the slot 2 cartridge's ink is low, the slot 4 cartridge's ink has run out, and no cartridge has been inserted in slot 5.
- The following icons indicate the status of each slot:

	Remaining ink amount : More than 80%, less than 100%		Remaining ink amount : Less than 20%
	Remaining ink amount : More than 60%, less than 80%		• The blinking indicates that smartchip recovery is being performed. <a href="#">"Smartchip recovery" P. 175</a>
	Remaining ink amount : More than 40%, less than 60%		Ink Low
	Remaining ink amount : More than 20%, less than 40%		Ink End
			No cartridge

The ink colors and slot locations for each color are shown below.

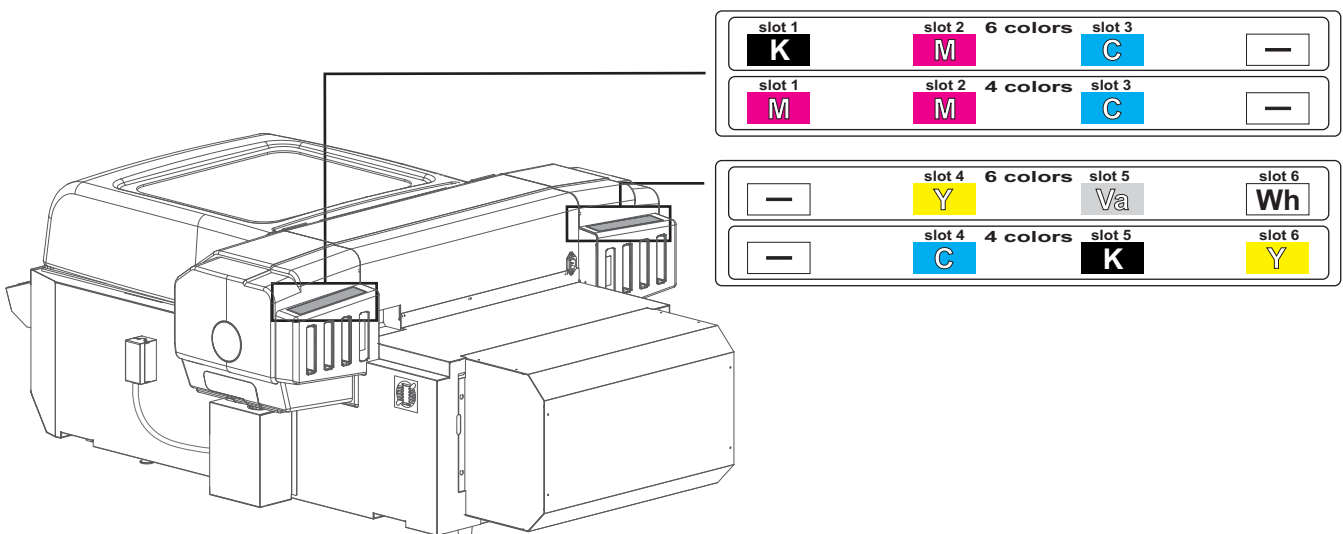

# System configurations of this product

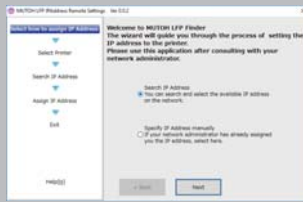

## MUTOH LFP Finder

It is included in the Startup Wizard to find your printer on the network and assign available IP address. (To change your IP address, please use MUTOH Status Monitor.)

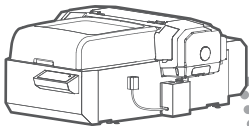

## Layout and Print Tool 2

Easy layout and print application that allows you to arrange multiple images and texts on a page and print it on your printer. You can save it with the printer settings you specified for reprint.



## MSM Mobile

Enables you to remotely monitor printer status and control your printer through remote panel on your smartphone or tablet.



## MUTOH Layer Editor

Mutoh layer printing application that enhances layer printing capability of printer driver and Layout and Print Tool 2.

### Main functions:

- Converts multiple data into a single print data set.
- Enables reutilization of layer print data.
- Prevents interruption by other print jobs, erroneous operations, etc.



## Printer driver

A printer driver that supports each OS in Windows.

### Main functions:

- Equipped with "White Print" functions that cope with white ink and varnish (clear top coat).
- Equipped with "Layer Print" functions that tie in with MUTOH Layer Editor.



## MUTOH Status Monitor (MSM)

Offers wide range of service including

- Monitor printer status, ink level and media remaining in real time.
- Control your printer through remote panel.
- Perform printer maintenance.

By signing up for MUTOH Club\*<sup>1</sup>, you can get the latest service.

Some of the service require internet access.

## \*1 MUTOH Club

By signing up for MUTOH Club, it offers free useful contents including

- Download the latest version of application, operation manual.
- Download media profile.
- Check printer information. (printer information uploaded through MSM can be viewed)



Internet

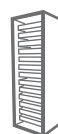

## MUTOH Club server



Log into MUTOH Club.

<https://club.mutoh.co.jp/mutoh/guser>

## Appropriate Use of Layout and Print Tool 2 and MUTOH Layer Editor

The CDROM supplied with this printer contains two print application; Layout and Print Tool 2 and MUTOH Layer Editor. To perform layer printing on XPJ-661UF, please use Layout and Print Tool 2.

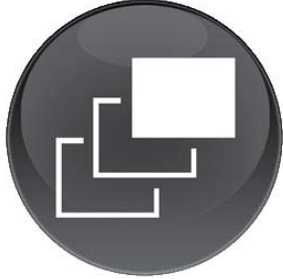
Each print application has following features.

	Layout and Print Tool 2	MUTOH Layer Editor
		
Functions	<p>Enables to print more than one image layer by layer on the same media. Users can edit layer printing layout for up to 15 layers and save them.</p>	<ul style="list-style-type: none"> <li>• Receives print data from the printer driver. Users can assign the received data to each layer to perform layer printing.</li> <li>• To create print data file, use Layout and Print Tool 2 or other graphic applications.</li> </ul>
Intended use	<ul style="list-style-type: none"> <li>• Suitable for small print production or adding text to an image.</li> <li>• Recommended to use MUTOH Layer Editor for large print production.</li> </ul>	<p>Saves print data with format converted for the printer to print soon after sending from MUTOH Layer Editor and efficiently reprint the same data.</p>
Image printing (PNG/TIFF)	○	×
Multi layer printing (Print layer by layer on the same media)	○	○
Single layer printing (Print 2 or 3 layers in one pass)	×	○
Change printer settings on output data	×	○ (Change carriage speed, vacuum fan and more)

### Note

For more details of layer printing and supported file format, see the Layout and Print Tool 2 Operation Manual and MUTOH Layer Editor Operation Manual.

## Displaying the Printing Preferences screen of printer driver

### [1] Windows 11

Press the [Win] - [R] keys on your keyboard to open the Run command window.  
In the search field, type "control", then click [OK] or press the [Enter] key on your keyboard.  
Click [Control Panel], then [Devices and Printers].

### Windows 10

Click [Start], [All Apps], [Windows System], then [Control Panel].  
In the screen that appears, click [Devices and Printers].

### Windows 8.1

Display the charm bar on Desktop, and click [Settings]. Click [Control Panel] - [View devices and printers].

### Note

Printer driver can run on Windows 11.

### [2]

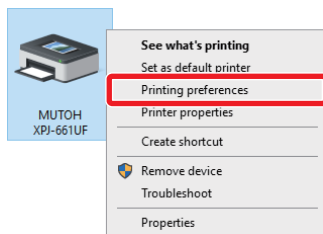

Right click the "MUTOH XPJ-661UF" icon and click [Printing preferences].

- The "Printer Configuration" dialog box opens only at the first time.
- The Printing Preferences screen of printer driver opens from the second time.

### [3]

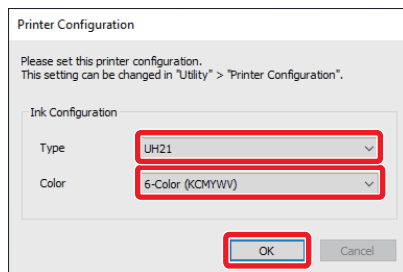

Select the ink type and the ink configuration settings and click [OK].

- After clicking, the Printing Preferences screen of printer driver opens.

### Note

- If you use the Windows printer driver, make sure to select the ink type and the ink configuration settings of your printer.
- If you selected the wrong ink configuration, go to [Utility] > [Printer Configuration] and select the correct one.



Printing Preferences screen of printer driver

# Launching/Displaying/Exiting MUTOH Status Monitor (MSM)

## Launching MSM



### Windows 11 / Windows 10

- Double click the MSM icon on the Desktop.

### Windows 8.1

- In the [Start] screen, click [Desktop].
- Double click the MSM icon on the Desktop.

### Note

Launching from the Start Menu of Windows

- Windows 11 / Windows 10  
From the [Start] menu, click [All Programs] (or [All Apps]) - [MUTOH] - [MUTOH Status Monitor].
- Windows 8.1  
Right click somewhere the [Start] screen tiles are not displayed to display the application bar, and click [All Apps].  
Click [MUTOH Status Monitor].

## Displaying MSM

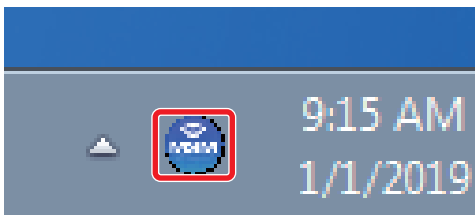

Double click the MSM icon in the task tray.

## Displaying remote panel

The remote panel allows you to view the printer status or remotely operate your printer.

Click [Remote Panel].

- The remote panel opens.

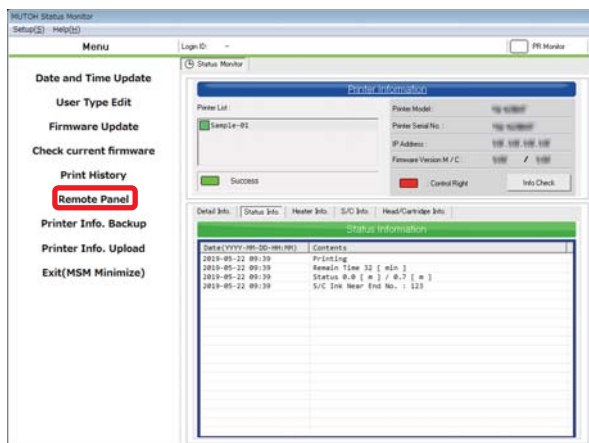

## Exiting MSM

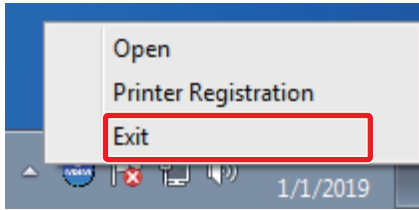

Right click the MSM icon in the task tray, and click [Exit].



While using your printer, do not exit MSM. To close the MSM window, click [Settings] - [Close].

### Windows 8.1

Click the Down Arrow in the [Start] screen.  
Click [MUTOH Status Monitor].

## Launching MUTOH LFP Finder

From the [Printer Registration] menu on the MUTOH Status Monitor, click "3. Search printer Assign/Change IP address".



If ValueJet Finder has been already installed, uninstall the ValueJet Finder.

## Launching Layout and Print Tool 2

### Windows 11 / Windows 10

From the [Start] menu, click [All Programs] (or [All Apps]) – [MUTOH] – [Layout and Print Tool 2].

### Windows 8.1

Display the charm bar on the desktop, and then click [Search].

Enter "Layout and Print Tool 2", and then click .

Click the "Layout and Print Tool 2" icon displayed in the search result.



Layout and Print Tool 2 can run on Windows 11.

## Launching MUTOH Layer Editor

### Windows 11 / Windows 10

From the [Start] menu, click [All Programs] (or [All Apps]) – [MUTOH] – [MUTOH Layer Editor] in order.

### Windows 8.1

Display the charm bar on the desktop, and then click [Search].

Enter "MUTOH Layer Editor", and then click .

Click the "MUTOH Layer Editor" icon displayed in the search result.

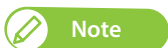

MUTOH Layer Editor can run on Windows 11.



## Displaying Help

A Help menu is available in the printer driver and MUTOH LFP Finder.

### Printer driver

Open the Printing Preferences screen of printer driver, and click [Help].

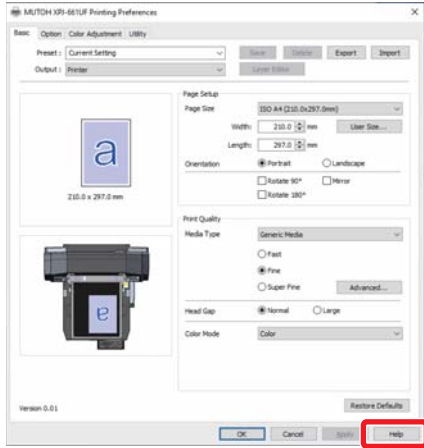

### MUTOH LFP Finder

Launch MUTOH LFP Finder, and click [Help].

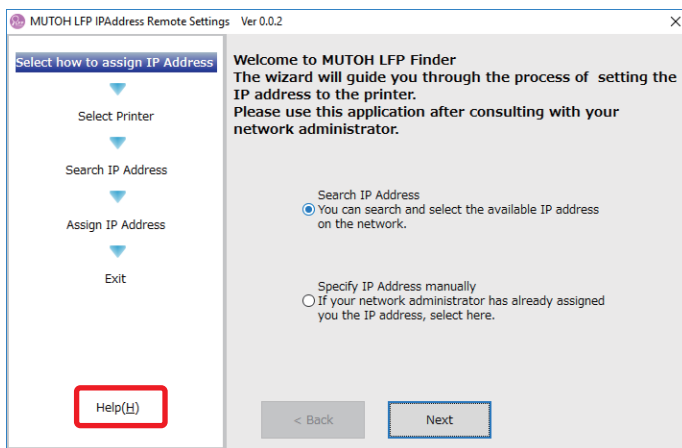

## Requirements for usable media

Media that meet the requirements below can be used with this printer.

### Usable sizes

Maximum width	483 mm
Maximum length	594 mm
Maximum thickness	150 mm
Surface height difference	approximately -0.5 mm maximum
Weight	up to 6 kg (including jig)

#### Important!

**The minimum media width and length that are settable in the User Type for the printer are 30 mm x 30 mm. To print onto media with dimensions smaller than these, you should take precautions to prevent the table from being dirtied with ink.**

#### Note

Contact your local MUTOH dealer about roll media recommended for your printer.

### Cautions for handling media

To achieve expected print quality, follow the instructions below.

Failure to follow these instructions could result in damage to the printer.

- Use media with no wrinkle, fold or curl.  
If media does not sit flat on the table, secure it on the table using a thin tape to avoid any warps.
- If media has a chance to be deformed while printing, secure it on the table using a thin tape to avoid head strike.
- Do not use media that is sensitive to heat.  
The heat given off by the UV rays could deform such media, or affect its image quality, or cause it to contact with the head.
- If printing onto a solid object that is liable to roll (such as a golf ball or ballpoint pen), use a jig or similar to stop it from rolling.
- When loading a small and heavy object or a jig on the table, place it as close to the center of the table as possible.
- Printing on non-flat surface media will generate ink mist, causing malfunction or damage to the printer.
- If you are printing on non-flat surface media and there is large distance between the print head and media, you may not be able to achieve predictable print quality.  
To print on such media with more than 0.5 mm height difference, it is recommended to use the "Low Speed" printing mode. It allows you to print on media up to 2.0 mm height difference and helps to minimize the ink mist, ink bleeding or layer shift.  
 [\\*\\*\\* > 7: Low Speed" P. 77](#)
- Printing on a light reflective material may have a chance to cure the ink on the print head, causing malfunction or damage to the product. To print on such materials, it is recommended to mask the non-print area on the material.

## Cautions for handling media

---

- When loading a new media, make sure to place it on an appropriate position and input correct media information. If wrong information is entered, the printer can print on an unintended position of the table. If UV ink stains on the table, it will be cured by UV lamp and will not be removed from the table.
- When using this product, do not place any object in the table height detection area. This will cause false detection and the printer will not be able to print correctly.  
Also, the area in front of the guide groove on the front side of the table is outside the sensing area of the obstacle detection sensor. Do not place any object thicker than the media being loaded in this area. This will cause head strike, leading to damage to the print head.  
For details, see the following section:

 ["Printing area" P. 32](#)

## Table Dimensions & Diagrams

The diagram below show the dimension of the table on this product.

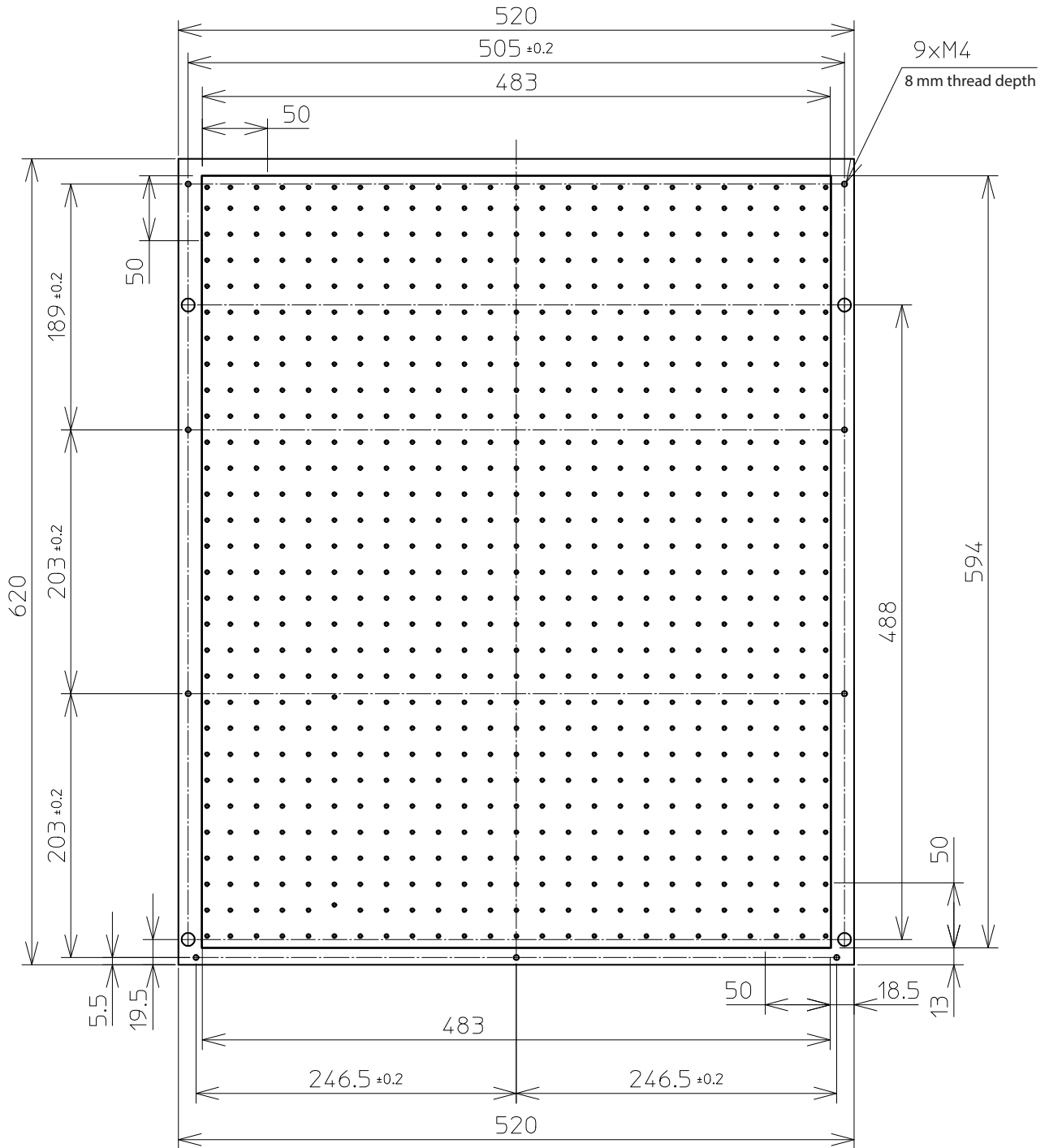

## Precautions when using this product

### Do not turn the power off

---

Use the printer with its power turned permanently on. When you are not using the printer, always leave the power on and put the printer into the sleep mode. In the sleep mode, the printer will periodically circulate the ink inside the printer and carry out head cleaning automatically. If you do not put the printer into the sleep mode, the ink inside the printer could settle out and/or coagulate, causing poor image quality or printer failure.

### Please handle ink carefully

---

- Before operation, make sure to read the Safety Data Sheet (SDS).
- Do not disassemble ink cartridge (or ink bag).  
Ink may come into contact with your eyes or skin, causing irritation or allergic reaction.
- Wear gloves, goggles or protective eyewear, protective mask, protective clothing when handling ink.
- DO NOT drop or hit an ink cartridge (or ink bag).  
Ink may leak from the container.
- Be sure to use the ink before it expires.  
Using expired ink can cause damage to the printer. Replace with a non-expired one even it has ink remaining.  
The expired ink should be disposed of as industrial waste. The empty ink cartridge (or ink bag) should be put in a plastic bag and should be disposed of according to the local regulations.
- MUTOH strongly recommends to use genuine ink.  
This printer is designed to bring out the best performance when using with the MUTOH genuine ink.  
Non-MUTOH ink may cause print defects or damage to the printer.

### Avoid direct contact with uncured ink

---

- The curing time for Mutoh UV ink varies by surface properties of media you use. Particularly a low ink density area on a print takes longer time to be cured (approximately one hour).  
When you check if your print is fully cured, be sure to wear protective gloves.
- When using this product, wear personal protective equipment (supplied gloves or solvent-resistant gloves, goggles or protective eyewear, protective mask, protective clothing) to avoid skin contact with ink.
- Especially during operations where ink might contact you (e.g. handling ink or waste fluid, cleaning of print head/cap/wiper), always wear personal protective equipment (supplied gloves or solvent-resistant gloves, goggles or protective eyewear, protective mask, protective clothing) to avoid skin contact with ink.
- If glove becomes contaminated with ink, replace it with new.
- If ink gets on skin, immediately wash with soap and plenty of water for 15 minutes. Seek medical advice/attention if irritation or inflammation are present.
- If ink gets in eyes, flush eyes with plenty of water for 15 minutes and seek medical advice/attention immediately.
- If swallowed, rinse mouth immediately and do not induce vomiting. Seek medical advice/attention.

## Agitate the ink

---

Before installing a new ink cartridge (or ink bag), invert it back and forth to agitate ink. Periodical ink agitation is also required when prompted on the operation panel.

Otherwise, the ink inside the ink cartridges (or ink bags) settles or coagulates and may cause poor print quality or a malfunction.

## Please use this product at least once a week

---

If the printer is not used for a long time, the print head nozzles can get clogged causing damage to the printer.

## Conduct periodic maintenance

---

This product requires daily maintenance.

- Perform the Nozzle check before and after printing.  
If nozzle clog is found, conduct a head cleaning.
- Make sure to perform daily maintenance after you finish printing for the day.  
Failure to perform daily maintenance may affect print quality or result in damage to the printer.  
 ["Daily Maintenance" P. 128](#)
- If you are not using the printer for an extended period\*, put it into sleep mode and then perform followings.  
\*"Extended period" means one to four weeks.
  - Agitate the ink.
  - Check the ink level and replace the relevant ink cartridge if "Ink Low" is displayed.

If you may not be able to perform above, follow the instructions of ["If not using the printer for a long time" P. 26](#) and power off the printer.

- Empty the waste ink tank when needed.
- Clean the interior of the printer once a month.

## Some parts need to be replaced periodically

---

In this product, following parts need to be replaced after a long-term use.

- Parts required to be replaced by users: Absorption material for the flushing box, Cleaning wiper, UV-LED lamp filter, UV-LED lamp emitting window glass.
- Parts required to be replaced by service personnel: Various motors, Pumps, Print head, Head cap unit, UV-LED lamp

## Safety precautions to open and close the maintenance cover

---

### CAUTION



- **Do not open or close the cover while you are off balance.**

You may pinch your finger or get injured.



- **Always fully open the maintenance cover.**

If you leave it half-open, the maintenance cover can suddenly close.

- **When closing the maintenance cover, hold the tab on the maintenance cover to gently close it.**

Do not place your fingers on the edges of the printer's opening portion, or on any parts around those edges. Your fingers could get caught and be injured.

To access to the wiper and the head cap unit for daily maintenance, you can open and close the maintenance cover on this printer.

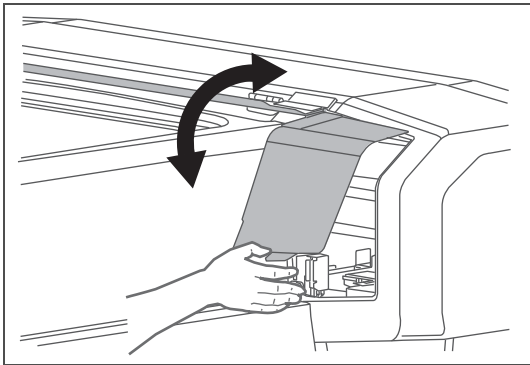

Hold the tab on the maintenance cover as shown on the left to gently open or close the cover.

# Powering ON / OFF

## Turning the power ON

[1] Close the front cover.

[2]

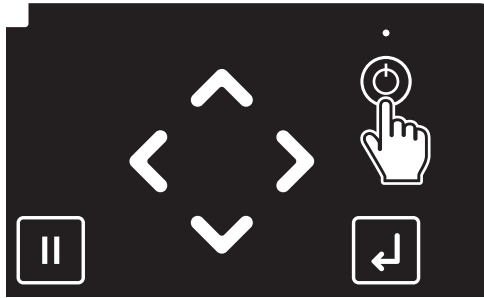

Long press the Power button.

- The keys on the operation panel light up.
- The printer will start mechanical initialization.

### Note

When the message "Welcome" appears and the LED lights on the panel turns on, release the button.

### Note

- During printer initialization, the printer performs table height calibration to optimize the gap between the print head and media.
- The table height calibration can be also performed from the operation panel "Maintenance 7: Calibration" menu.

👉 ["Calibrating table height" P. 55](#)

### Important!

When using this product, do not place any object in the table height detection area. This will cause false detection and the printer will not be able to print correctly.

Also, the area in front of the guide groove on the front side of the table is outside the sensing area of the obstacle detection sensor. Do not place any object thicker than the media being loaded in this area. This will cause head strike, leading to damage to the print head.

For details, see the following section:

👉 ["Printing area" P. 32](#)

## Turning the power OFF

If you need to power off your printer temporarily, follow these steps.

### Important!

- **Use the printer with its power turned permanently on. When you are not using the printer, always leave the power on and put the printer into the sleep mode while not in use. If you do not put the printer into the sleep mode, the ink inside the printer could settle out and/or coagulate, causing poor image quality or printer failure.**

👉 ["Sleep Mode" P. 30](#)

- If you are not using the printer for an extended period of time (up to one month), follow these steps to power off the printer.

👉 ["If not using the printer for a long time" P. 26](#)

[1] Check that the printer completes printing and no object including a jig is loaded on the table.

[2] Prepare items required for daily maintenance.

👉 ["Preparing for Daily Maintenance" P. 129](#)



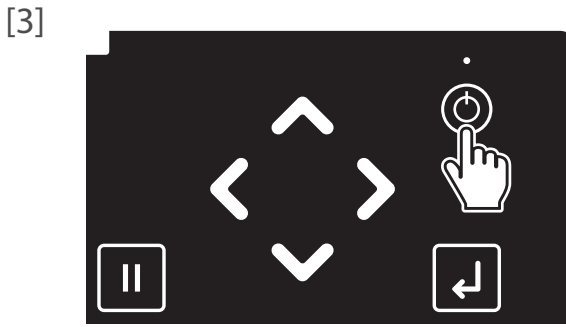

Long press the Power button.



To skip a daily maintenance and power off the printer, tap [Cancel].

👉 ["Powering off the printer without daily maintenance" P. 29](#)

- Powering off the printer without daily maintenance will cause ink accumulation around the print head, leading to damage to the printer. Normally, be sure to perform daily maintenance.

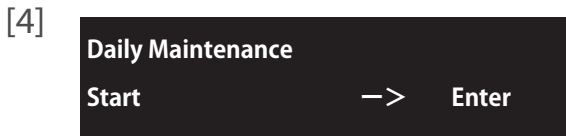

Tap [Enter].



The table moves to the front side of the printer.

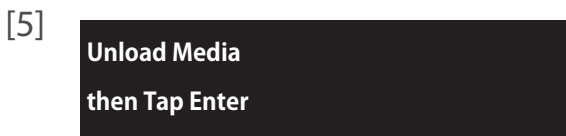

Remove the media and the jig on the table, and then tap [Enter].



- The table, carriage and cleaning wiper move to gain access to daily maintenance.

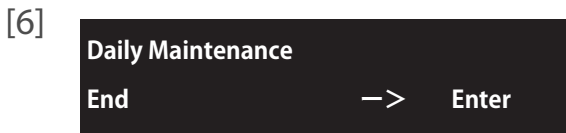

The message on the left will appear.

- You can start daily maintenance.

👉 ["Performing Daily Maintenance" P. 131](#)

- After the daily maintenance is complete, tap [Enter].



The message on the left will appear.



The printer automatically performs the Short cleaning.



After the Short cleaning, this printer will start turning off.

## If not using the printer for a long time

If your printer will be not in use for a long period of time (up to one month), follow these steps to power off the printer.

### 1. Performing Daily Maintenance

[1] Check that the media and jig are removed from the printer.

[2] Prepare items required for daily maintenance.

 ["Preparing for Daily Maintenance" P. 129](#)

[3] Tap [Home].

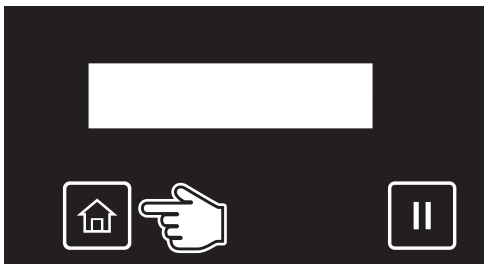

[4] 

- Use  to choose the menu shown left.
- Tap .

[5] 

- Use  to choose the menu shown left.
- Tap .

[6] Tap [Enter].

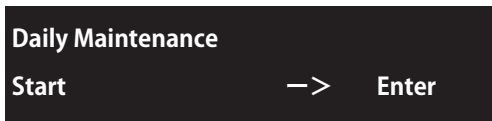

The table moves to the front side of the printer.



[7] Remove the media and the jig on the table, and then tap [Enter].



- The table, carriage and cleaning wiper move to gain access to daily maintenance.

[8] You can start maintenance.

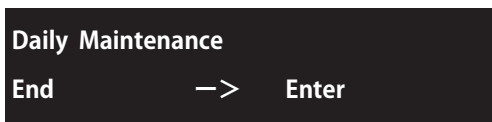









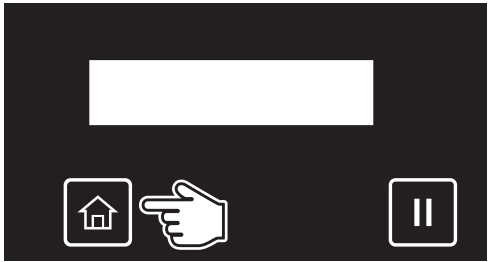





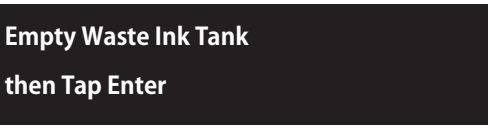

 ["Performing Daily Maintenance" P. 131](#)

- Once the maintenance is finished, close the front cover, then tap [Enter].

 ["Finishing maintenance" P. 141](#)

## 2. Discharging ink from the printer

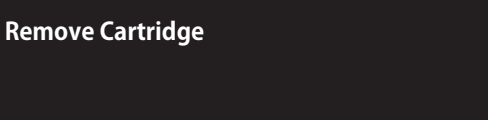
- [1]  Tap [Home].
- [2] 
  - Use  to choose the menu shown left.
  - Tap .
- [3] 
  - Use  to choose the menu shown left.
  - Tap .
- [4]  Tap [Enter].  

- [5]  Drain the waste ink into the container, then tap [Enter].  
  
 ["Drain waste ink into a container" P. 125](#) under ["Emptying waste ink tank"](#)
- [6] 
  - Use  or  to choose the message "Empty the Tank? Yes".
  - Tap [Enter]. 
-  The message on the left will appear.

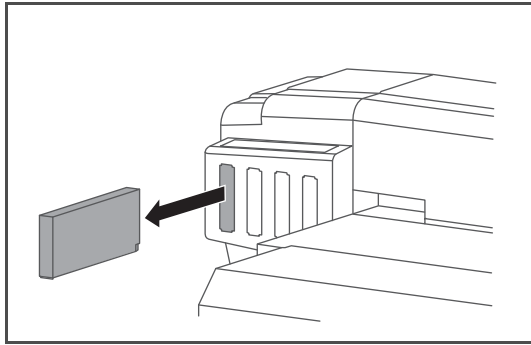
[7]



Remove the ink cartridges (or high-capacity ink pack adapters) from all the cartridge slots.

Discharging \*\*%

The message on the left will appear.

- Discharging the ink will start.

No Cart. XXXXXX

When the message on the left appears, transfer the waste ink into a container.

 ["Drain waste ink into a container" P. 125](#) under ["Emptying waste ink tank"](#)

[8]

Reset the waste ink counter.

 ["Resetting waste ink counter" P. 127](#)

### 3. Powering off the printer without daily maintenance

---

[1]

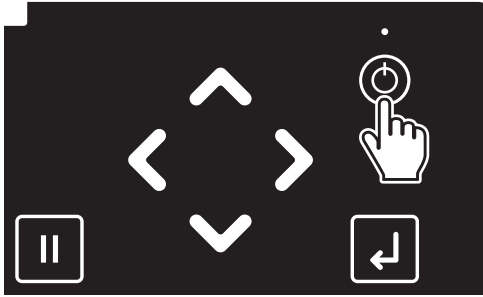

Long press the Power button.

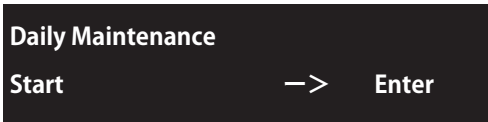

The message on the left will appear.

[2]



Tap [Cancel].



This will skip a daily maintenance.



**Make sure to perform daily maintenance before powering off the printer.  
Failure to do so will cause nozzle clogging.**

[3]



The printer will start turning off.

# Sleep Mode

When you are not using the printer, always leave the power on and put the printer into the sleep mode while not in use. If you do not put the printer into the sleep mode, the ink inside the printer could settle out and/or coagulate, causing poor image quality or printer failure.



Make sure to follow the instructions on the operation panel to perform daily maintenance.

The following operations are performed during sleep mode.

- Automatic Head cleaning by timer set in the "SetTimer" Menu.
- Ink circulation
- "Little Charge"

## Important!

To leave the printer in sleep mode for seven days or more, perform followings once a week:

- Check the ink level and replace the relevant ink if "Ink Low" is displayed.  
 ["Replacing ink" P. 120](#)
- Agitate the ink.  
 ["Agitating ink" P. 116](#)

## Steps

- [1] Make sure that the printer's operating condition is as follows:
- The Front cover and the maintenance cover are closed.
  - No object including a jig is loaded on the table.
  - The remaining ink level is sufficient.
  - The waste ink bottle has enough space.

## Important!

If you are going to use the sleep mode for a prolonged period of time, first empty the waste ink tank.

 ["Emptying waste ink tank" P. 124](#)

- [2] Prepare items required for daily maintenance.

 ["Preparing for Daily Maintenance" P. 129](#)

- [3]  Tap [Home].

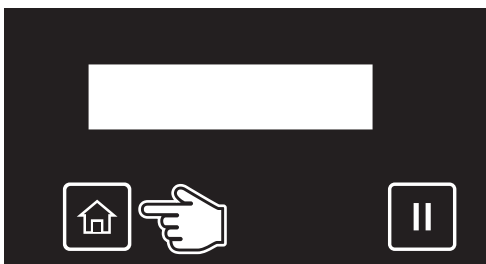

- [4]  • Use  to choose the menu shown left.  
• Tap .



- [5]  Tap .



[6] Sleep Mode  
Start —> Enter

Tap [Enter].



[7] Daily Maintenance  
Start —> Enter

Tap [Enter].



Please Wait

The table moves to the front side of the printer.

[8] Unload Media  
then Tap Enter

Remove the media and the jig on the table, and then tap [Enter].



Please Wait

- The table, carriage and cleaning wiper move to gain access to daily maintenance.

[9] Daily Maintenance  
End —> Enter

The message on the left will appear.

- You can start daily maintenance.

 ["Performing Daily Maintenance" P. 131](#)

After the daily maintenance is complete, tap [Enter].



Please Wait

The message on the left will appear.

Cleaning \*\*%

The printer automatically performs the Short cleaning.

[10] Sleep Mode  
End —> Enter

- The sleep mode will start.
- To exit the sleep mode, tap [Enter].



 Note

- While in sleep mode, the small LED light above the power button flashes every 5 seconds.
- To set the timer for automatic head cleaning during sleep mode, see ["Sleep Mode2: Cleaning Timer" P. 107](#).
- Depending on the elapsed time from the previous automatic maintenance, the printer may automatically execute head cleaning and/or ink charging, etc., when it exits the sleep mode. Such operation does not depend on the sleep mode settings. It is an automatic maintenance function of the printer.

## Printing area

- When loading new media, you need to enter the media size (width and length) and origin position (print start position) from the operation panel.
- The guide groove on the table shows the maximum printable area (483 mm x 594 mm).
- Use the screw hole (M4) to attach your own jig.
- Printing is always started from Origin position (print start point). See the figure below as example.
- See "[Table Dimensions & Diagrams](#)" P. 20 for detailed dimension.

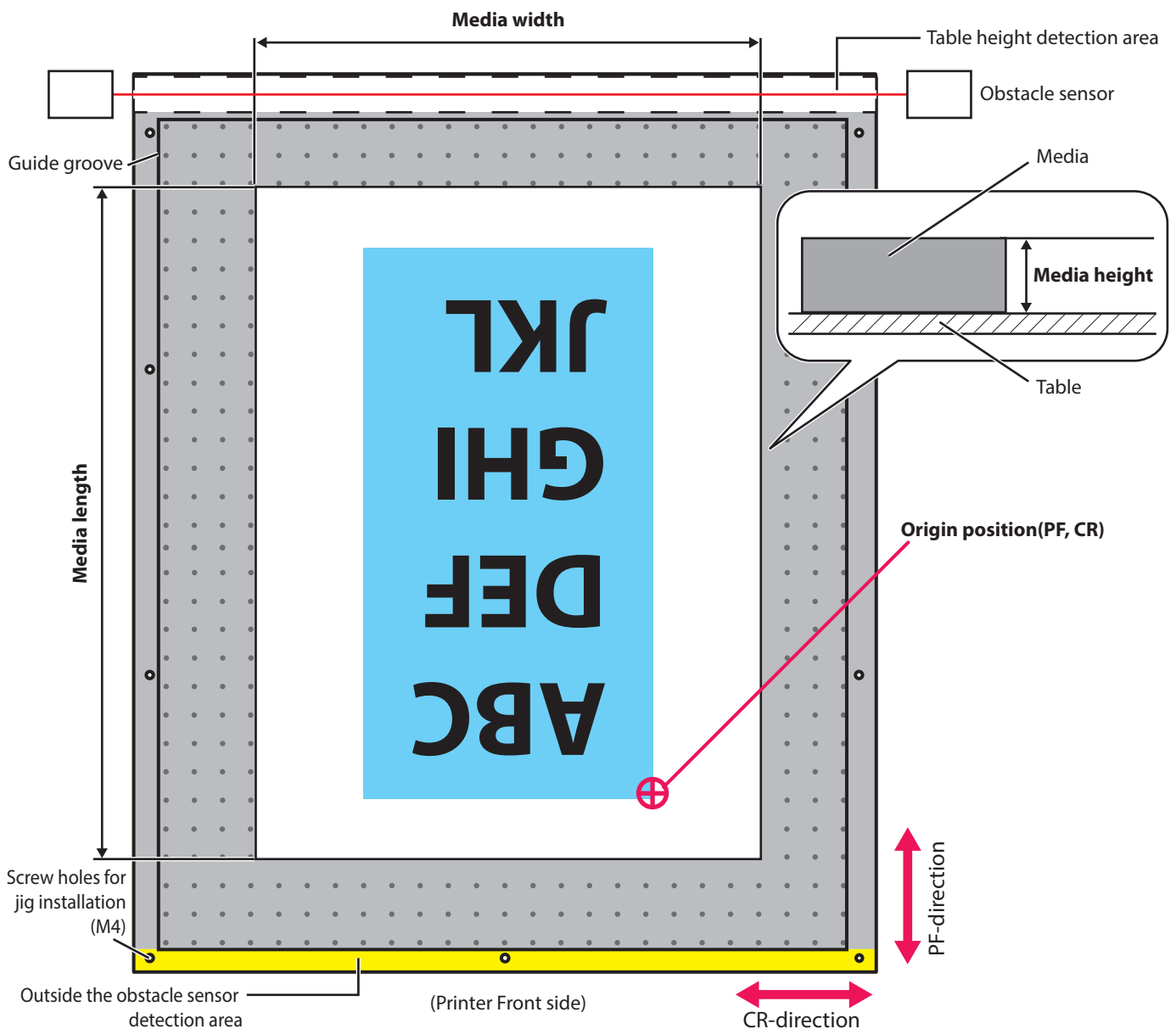

### Important!

**When using this printer, DO NOT place any objects in the table height detection area. Otherwise, it will cause false detection of the obstacle sensor and the printer may not be able to print correctly.**

**Also, the area in front of the guide groove on the front side of the table is outside the sensing area of the obstacle detection sensor. Do not place any object thicker than the media being loaded in this area. This will cause head strike, leading to damage to the print head.**



## Loading media

### Important!

- When loading a new media, make sure to place it on an appropriate position and input correct media information. If wrong information is entered, the printer can print on an unintended position of the table. Once UV ink stains on the table, it will be cured by UV lamp and will not be removed from the table.
- When using this product, do not place any object in the table height detection area. This will cause false detection and the printer will not be able to print correctly. Also, the area in front of the guide groove on the front side of the table is outside the sensing area of the obstacle detection sensor. Do not place any object thicker than the media being loaded in this area. This will cause head strike, leading to damage to the print head.

For details, see the following section:

 ["Printing area" P. 32](#)

### 1. Placing the media on the table

- [1] **Set media, then**  
**Tap [^] key.**

Check that the message on the left is displayed.  
If not displayed, tap .

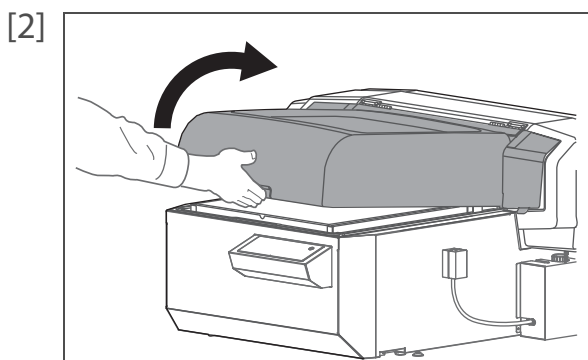





Hold the handle on the front cover to gently open it.

- Set media, then**  
**close cover.**  

The message on the left will appear.

#### Note

When using the optional vacuum table, you can change the vacuum power of the current job by tapping  or  while the message on the left appears on the panel. The vacuum power can be selected between 0 and 4 (0: turn the vacuum fan off).

The vacuum fan turns on by tapping  or .

The change made will be saved in the user type currently selected.

[3]

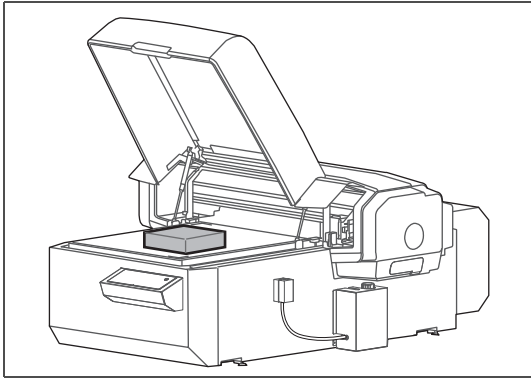

Place the media on the table.

[4]

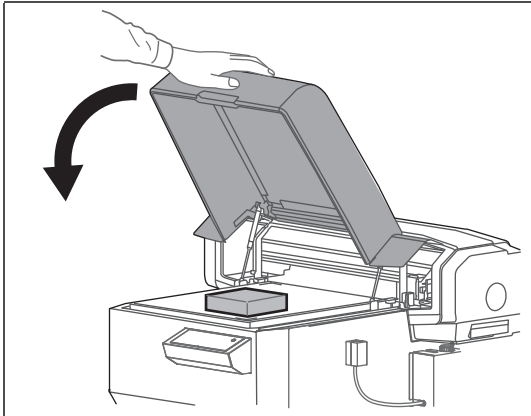

Hold the position shown on the left and gently close the cover.

[5]

Set media, then  
Tap [^] key.

Tap .





[6]

\*\*Detailed-Set:  
  
On

Tap [Enter].



 Note

- This menu only appears when the User Type are selected for the first time.
- If you select "On", you will have to input the media height, obstacle detect, media size and origin position after tapping  each time you set a media on the table.
- If you select "Off" via , "Ready to Print" will be displayed after tapping  each time you set a media on the table. In that case, the currently selected User Type values will be used for the media height, obstacle detect, media size and origin position.
- Even if "Off" is selected, you can enter media height, obstacle detect, media size and origin position from the "\*\*\*: Media Setting1 Set Media" by tapping [Cancel] while the message "Print Ready" or "Set media, then Tap[^] key." appears on the panel.

## 2. Media Height Setting & Printer Response Setting for Obstacle Detection

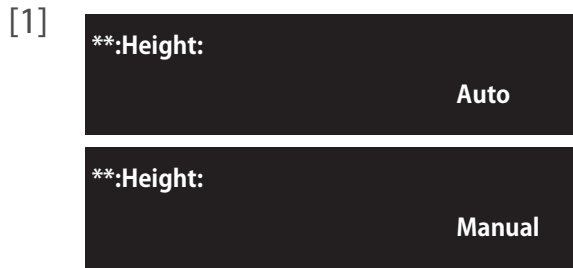

Use  or  to configure media height setting.

- “Auto”: Printer automatically detects height of media and lowers the table until the obstacle sensor detects no obstacle.
- “Manual”: User manually input height of media.

Tap [Enter].



In “Auto” Setting



Use  or  to specify the offset value between the print head and media.

Tap [Enter].



Note

The default head gap from the surface of media is set to 1.2 mm.

When you want to increase the head gap, use this menu to specify value in range of 0.0 mm to 1.5 mm.

- Example: If “PG Offset” is set to 0.5 mm, the head gap from the surface of media will be 1.7 mm (1.2 mm + 0.5 mm).

In “Manual” Setting

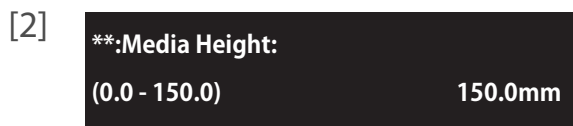

Use  or  to input the media height.

Tap [Enter].





Note

Any value from 0.0 mm to 150.0 mm can be set for the height.

[3]

**:.Obstacle Detect:	Auto
**:.Obstacle Detect:	Print Cancel
**:.Obstacle Detect:	Confirm

Use  or  to configure the printer response setting for obstacle detection.

- "Auto": The printer pause the printing. It lowers the table until the sensor does not detect any obstacle, and then resumes the job.
- "Print Cancel": The printer cancels printing and prompts the obstacle error message.
- "Confirm": The printer pauses the printing and allows users to choose from two options; Print Continue or Print Cancel.

Press the [Enter] key.



 Note

- If the sensor still detects the obstacle after the table moves down to its lowest position, the printer cancels printing and prompts the obstacle error message.
- For details on the related sections of the Panel Setting menu, see the following. ["\\*\\*\\*>9: Obstacle Detect" P. 78](#)

[4]

Please Wait

The message on the left will appear.

- While the table is moving to the print start position, the obstacle sensor will detect the media.

If no obstacle is detected, move to the next step.

 ["Inputting the media width, length and the origin position" P. 36](#)

If any obstacle is detected, an obstacle error message will appear on the operation panel.

- Tap  and then enter the height of media.

 ["Loading media" P. 33](#)

 ["Media Height Setting & Printer Response Setting for Obstacle Detection" P. 35](#)

### 3. Inputting the media width, length and the origin position

[1]

\*\*:.Width:  
(30 - 483) 483 mm



Use the  or  to input the media width. Tap [Enter].



 Note

- Any value from 30 mm to 483 mm can be set for the width.

[2] **\*\*Length:**  
(30 - 329) 329 mm





Use the  or  to input the media length.  
Tap [Enter].



 **Note**

Any value from 30 mm to 594 mm can be set for the length.

[3] **\*\*Origin:**  
PF: 0.0 CR: 0.0

- Use  or  to enter the PF (longitudinal) value.
- Use  or  to enter the CR (lateral) value.
- Tap [Enter].



 **Note**

any value between the following range can be entered:

PF value: 0.0 to 574.0





CR value: 0.0 to 463.0

**Moving To  
Origin Position**

- The table will move inward.
- The carriage will move to the set position, with its LED pointer lit steady.

[4] **\*\*Origin:**  
PF: 0.0 CR: 0.0

Check the position of the LED pointer.

- If it shows the correct position, tap [Enter].
- If it is not in the intended position, adjust the origin position as follows:
  - Use  or  to move the table forward/backward.
  - Use  or  to move the LED pointer leftward/rightward.
- Tap [Enter].



**Please Wait**

The message on the left will appear.

**Print Ready**



**Type 1**

That completes setting of the media.

## Nozzle check and cleaning

Before starting everyday operation, please perform nozzle check printing to check the print head condition. If nozzle clog is found, conduct cleaning.

This printer offers the following 2 kinds of nozzle checks:

- Nozzle Check - Prints the nozzle check patterns  
 ["For the Nozzle Check pattern printing" P. 38](#)
- Nozzle Check B - Prints the nozzle check patterns on the partially colored background.  
 ["For the Nozzle Check B pattern printing" P. 39](#)

### Note

- "Nozzle Check B" will only appear in the menu if 6-color is set.
- When using white ink, colored media, transparent films or semi-transparent films (such as OHP film, tracing paper and more) are recommended to use for nozzle check.

## 1. Run a nozzle check print

### For the Nozzle Check pattern printing

- [1] Load a roll media for Nozzle check.
- Load an A4 or larger size media in landscape orientation on the table.
-  ["Loading media" P. 33](#)

### Important!

**The minimum required media size for nozzle check printing is width 260 mm x length 35 mm. If you use a media that is smaller than this, the printing will overshoot it.**

**Once UV ink stains on the table, it will be cured by UV lamp and will not be removed from the table.**

- [2]  Check that the message on the left is displayed.



- [3]  Tap .

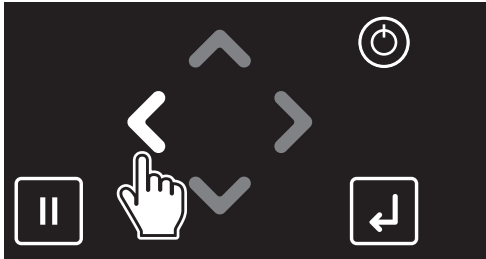

- [4]  Tap [Enter].
- The printer will print the nozzle check pattern.



- [5] Look at the print.
- If you find missing or thin lines on the print, go to ["Perform cleaning" P. 40.](#)
  - If all lines are clearly printed, go to ["Starting printing" P. 41.](#)
  - The figure below are examples of the Nozzle Check patterns.

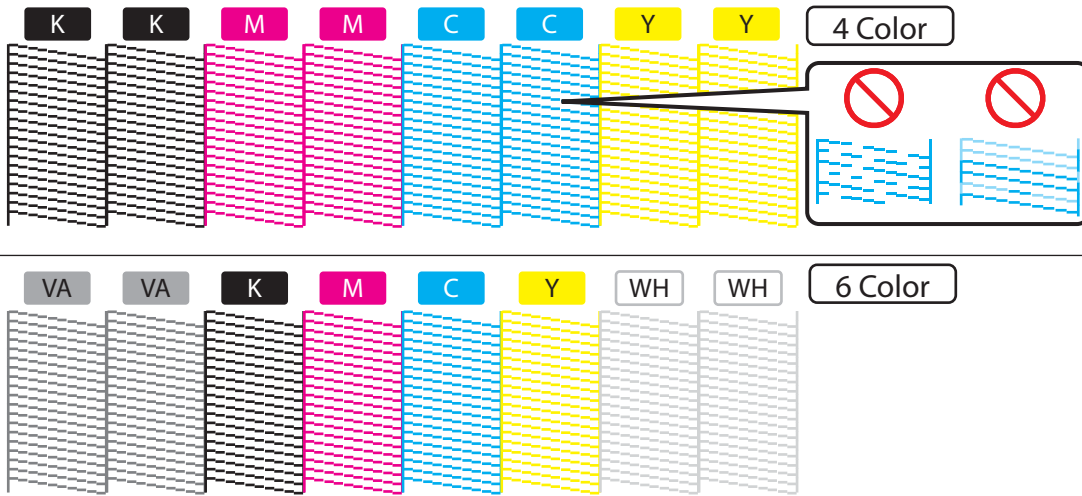

Note

The printer information (date and time of printing, printer's serial number, firmware version) is printed on the nozzle check pattern.

### For the Nozzle Check B pattern printing

- [1] Load a roll media for Nozzle check.

["Loading media" P. 33](#)



Check that the message on the left is displayed.



Tap [Home].



- Use to choose the menu shown left.
- Tap .



- Use to choose the menu shown left.
- Tap [Enter].



- [6] Look at the print.
- If you find missing or thin lines on the print, go to ["Perform cleaning" P. 40.](#)
  - If all lines are clearly printed, you can start printing.

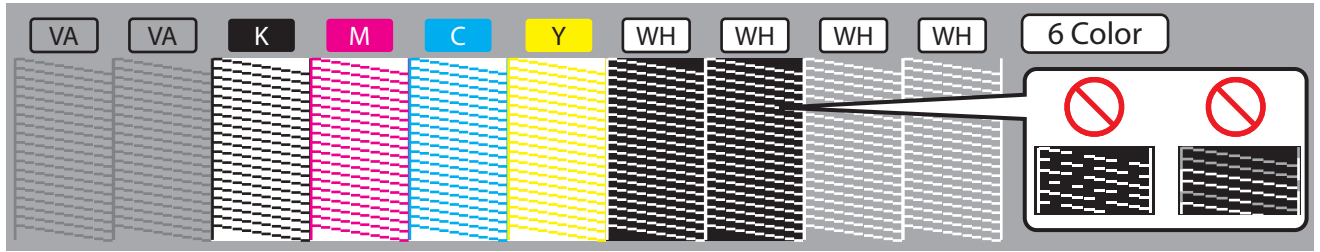

Note

- The figure above is an example of the Nozzle Check B pattern. In this example, non-colored background area is shown in gray.
- Printer information (Data and time printed, serial number, firmware version) is printed next to the pattern.

## 2. Perform cleaning

- [1] Check that the message on the left is displayed.

- [2] Tap .

- [3] Use or to choose the cleaning mode. Tap [Enter].
- The printer will start cleaning.



- [4] Run a nozzle check print again.  
["Run a nozzle check print" P. 38](#)

- If the nozzles do not recover after several normal cleaning attempts, try "Long" or "Little Charge" cleaning. For the details of cleaning, see ["Head cleaning" P. 137.](#)

Note

If "Long" or "Little Charge" cleaning does not help to recover the nozzles, go to ["Advanced Settings 10: Select Nozzle" P. 87](#) to select the nozzles that fire properly.



# Starting printing

## Printing from the Layout and Print Tool 2

You can lay out and print out the images using the bundled CD-ROM software, Layout and Print Tool 2.

This section explains the basic printing instructions only. For the details, see the operation manual for Layout and Print Tool 2.

Layout and Print Tool 2 supports following graphic file formats:

- PNG (.png)
- TIFF (.tif)

### Note

For the details of supported file format, see the Layout and Print Tool 2 Operation Manual.

[1] Start Layout and Print Tool 2.

 ["Launching Layout and Print Tool 2" P. 16](#)

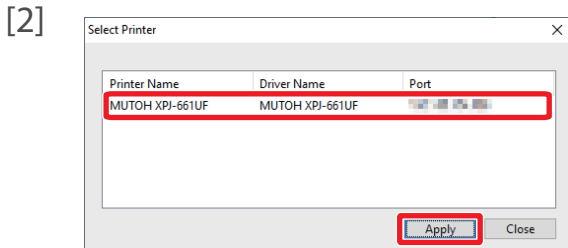

Select the printer driver.

- Click [Apply].

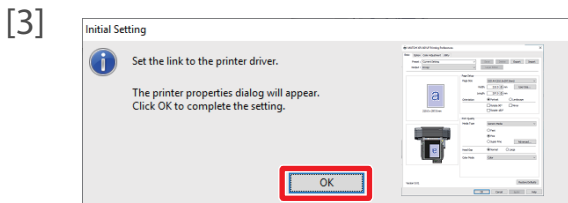

If the driver settings have not been completed, the dialog on the left will appear.

- Click [OK].

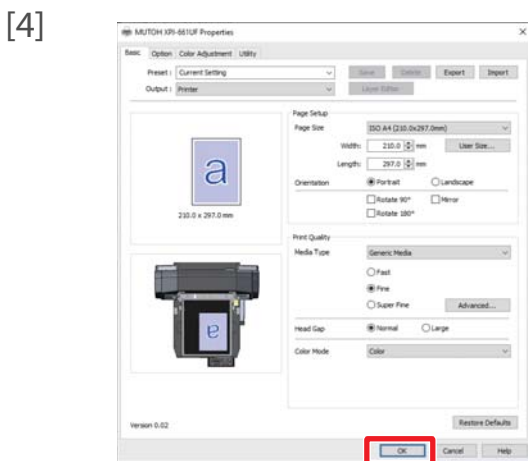

The dialog on the left will appear.

- Click [OK].

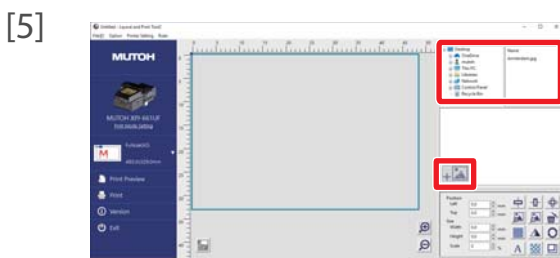

Select the image to be used in printing.

- Click the  button to insert the image.

[6]

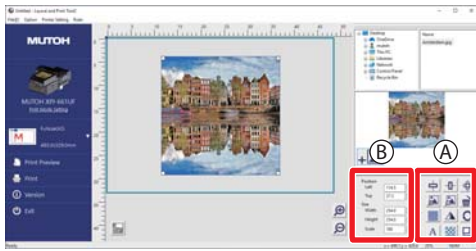

Align the image by using the following methods:

- Click the edit buttons (A on the left illustration).
- Enter values directly (B on the left illustration).

[7]

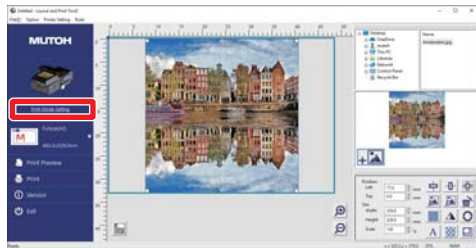

Click [Print Mode Setting].

[8]

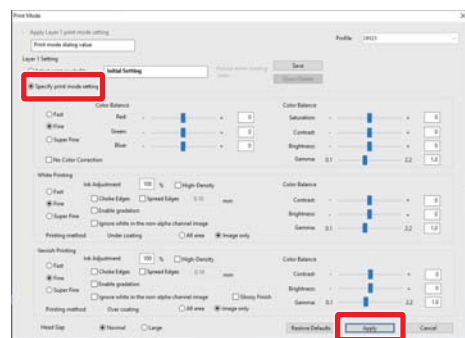

- Select [Specify print mode setting].
- After specifying all the settings, click [Apply].

[9]

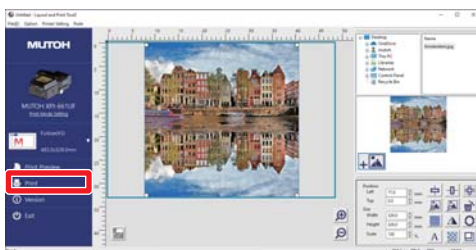

Click [Send to Layer Editor].

- The “Choose Print Mode” dialog will appear.

[10]

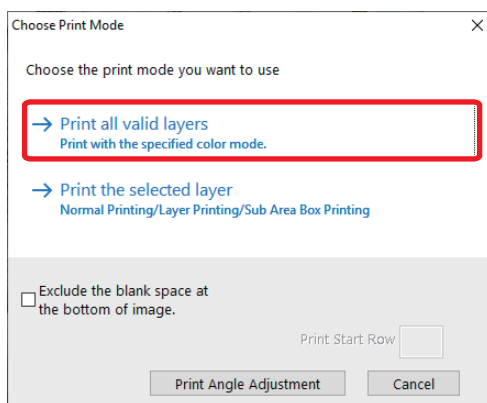

Select the Print Mode.

- Printing is executed.



Note

For more details of layer printing, see the Layout and Print Tool 2 Operation Manual.

## Printing from the Printer driver

In this section, a method to print from the printer driver is explained.

- [1] Open printing data from application software to execute printing.
- [2] Open the print setup screen of the XPJ-661UF printer driver from the application software.

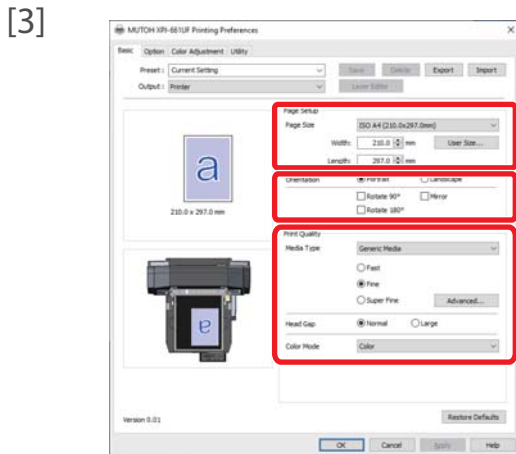

Conduct print setup.

- Set [Page Size], [Orientation] and [Print Quality].

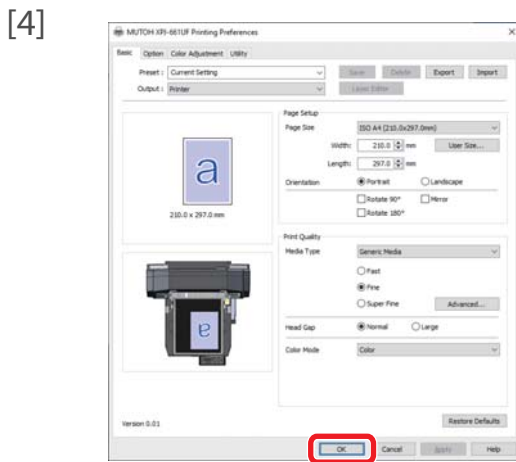

Click [OK].

- [5] Printing is executed.

## Pausing/Restarting printing

[1]

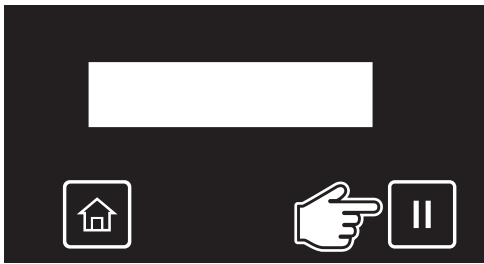

- Tap [Cancel] while printing.
- The printer will pause printing.

### Note

- You cannot cancel the job by tapping [Cancel].
- To cancel the job, see the following section.

 ["Canceling printing" P. 44](#)

[2]



- Tap [Cancel] again to resume printing.



### Important!

**MUTOH cannot guarantee the print quality when you resume the printing.**

## Canceling printing

[1]

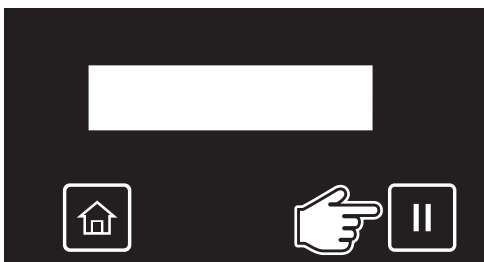

- Tap [Cancel] while printing.
- The printer will pause printing.

### Note

To resume printing, tap [Cancel] again.

[2]



- Tap [Enter] to cancel printing. (Once canceled, you cannot resume the job again.)

- The data sent to the printer will be deleted.



### Note

You can also cancel the job from the remote panel on MSM.

## Menus you can access while printing

- [1] Tap [Home] while one of the three messages on the left appears on the touch panel.

Receiving

Printing

Converting



- [2] Use  or  to choose the menu, then tap .

Menu1

PF Micro Adjust

Menu2

Backup

Menu3

Job Status

Menu4

Reset Waste Ink



 ["Menu1: PF Micro Adjustment" P. 46](#)

 ["Menu2: Backup" P. 46](#)

 ["Menu3: Job Status" P. 47](#)

 ["Menu4: Reset Waste Ink" P. 48](#)

## Menu1: PF Micro Adjustment

---

You can change the micro adjustment value to correct media feeding for the currently print job.

- See the following related sections of Panel Setting Menus

 ["\\*\\*\\*>4: PF Adjust" P. 72](#)

[1]

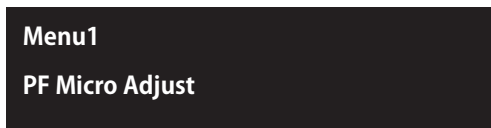



Tap .

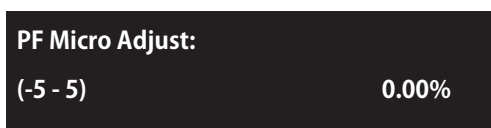

[2]



Use  or  to change the value.

- Tap [Enter] to confirm the change.



 Note

- The change made is applied to the current job only and is not saved in the printer.
- To save the change in the user type currently selected, go to ["Menu2: Backup" P. 46](#).

## Menu2: Backup

---

With this menu item, you can have a change that you made via "Menu1: PF Micro Adj." reflected in the currently selected User Types.

[1]



Tap .



[2]

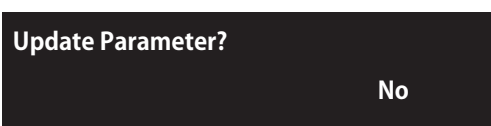

Use  or  to select "Yes".

- Tap [Enter].

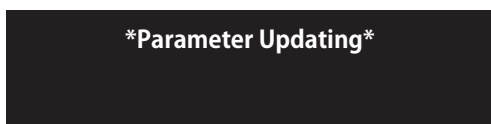

The change is saved in the selected user type.

## Menu3: Job Status

---

You can check the current status of the print job being printed.



- See the following related sections of Panel Setting Menus:

 ["Printer Status 3: Job Status" P. 104](#)



Tap .



Use  or  to choose the information you want to check.



- ToDoLength: displays the length of the current job (in media feeding direction).
- Done: displays the length of the current job that has been already printed.
- Remain: displays the remaining length to finish printing.
- Remain time: displays remaining time to finish printing.

### Note

- Indicated value is approximate. The accuracy of the value is not guaranteed.
- If the print job data does not contain length information, "0" will be displayed in the Job Status menu.

## Menu4: Reset Waste Ink

---

Use this menu to reset the waste ink counter to zero, if you empty out the waste ink tank during printing.

[1]



Tap .



[2]

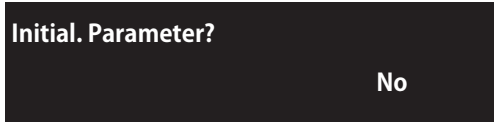

Use  or  to select "Yes".

• Tap [Enter].

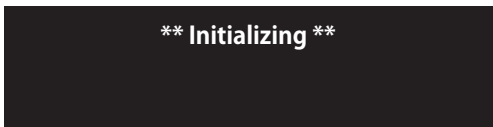

The counter will be reset to zero.



## Checking the printing area

To avoid printing on an unwanted area on your media, the Show Edges function helps to check the printing area of the print data before printing. By specifying this setting before printing, LED pointer shows where the image will be printed on the media. This helps to avoid misprinting especially when printing on an object that you do not have more than one pieces.

With this function, you can check the following:

- Whether an image can be printed on the intended area on the media.
- Whether the print data can be fitted on the media.

### Operation

- Locate the four corners of the printing area by the LED pointer.
- The LED pointer flashes (every second) on the point.
- The LED pointer lights up when moving from point to point.
- If the print data is too big for the media, the LED pointer flashes fast (twice a second) on the point.
- Move the LED pointer from the "position1" to "position4" in order in the following illustration.

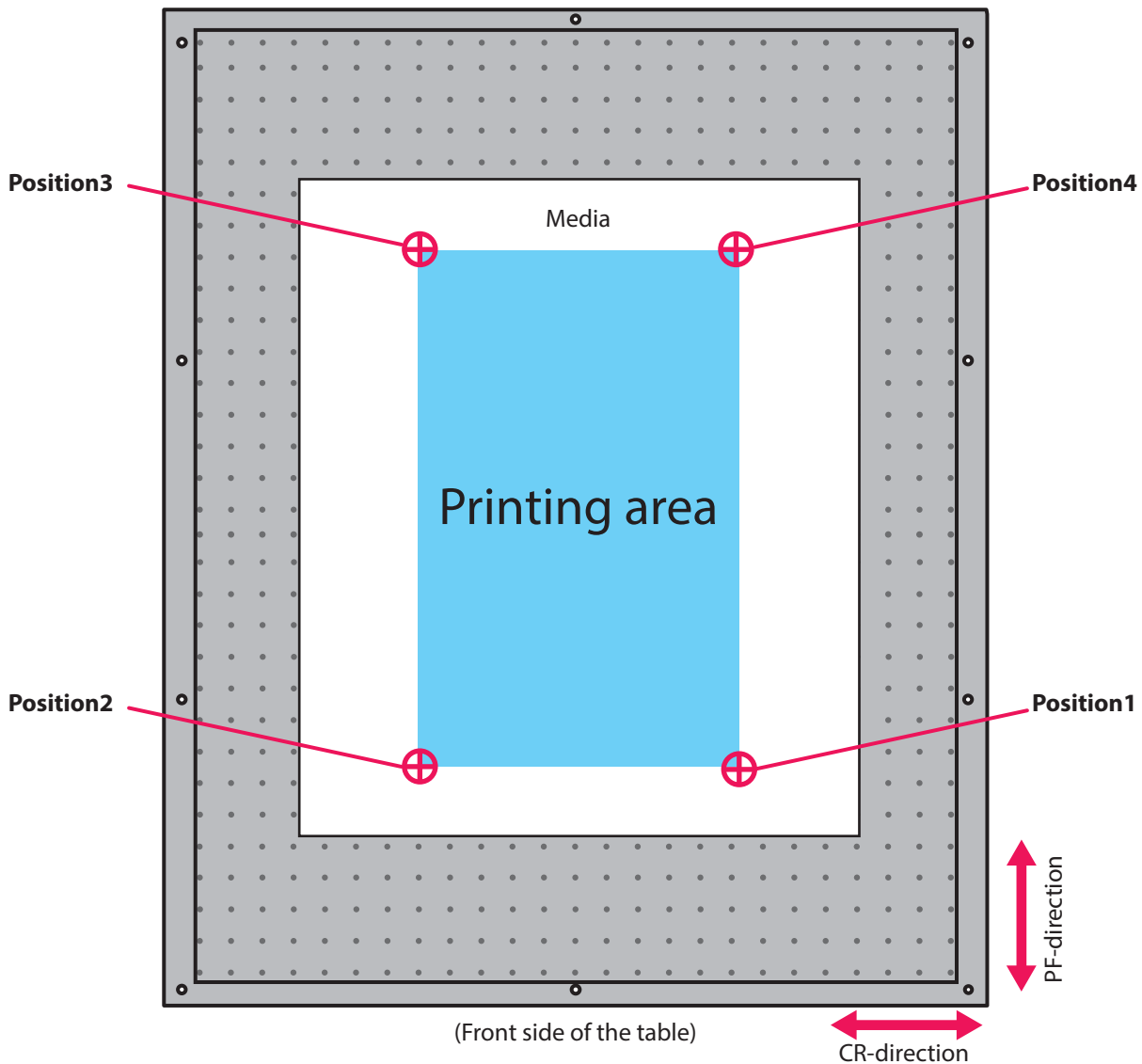

#### Note

When the print data does not have the length information (PF direction length), the LED pointer does not move from Position3 and 4.

# 1. Setting "Show Edges" function



Tap [Home].



Tap



Tap



Use or to select the user type.  
• Tap [Enter].



Important!

If you have changed the user type to another type, all settings that can be changed by user type settings change to the settings of the selected user type.

- When the "media setting" for the user type settings have been changed, the settings for the "media height", "obstacle detect", "media size" and "origin position" are changed to the settings of the selected user type. Therefore, be careful with the print start position. Images might be printed at the position that was not intended or outside the media.
- You can change the settings for the "media setting" from the Panel Setting menu.

[\\*\\*\\*>6: MediaSetting" P.75](#)



- Use to choose the menu shown left.
- Tap .

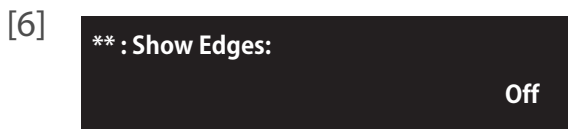

Use or key to select the setting.

- Off: LED pointer does not show the printing area. This is the default setting.
- Step: LED pointer shows where the image will be printed on the media and the printer will ask you at each point of corner if the position is OK.
- Auto: LED pointer shows where the image will be printed on the media without checking with the user.

• Tap [Enter].

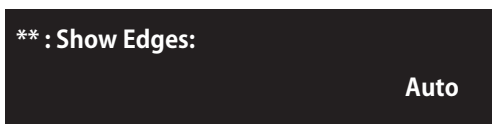
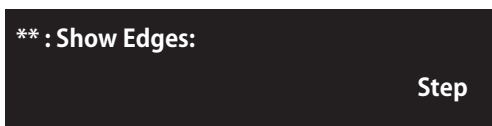

## 2. How to check the printing area

This section explains about when the checking method is set to "Step".

### Note

When it is set to "Auto", the following steps 2 to 5 are skipped. After step 1, the LED pointer moves from the "position1" to "position4" in order

[1]

Show Edges  
Start →Enter

- When the media is loaded and the print data is sent to the printer, the left message is displayed.
- Tap [Enter].



### Note

If you tap , the printer starts printing without showing printing area.

Please Wait

- The LED pointer moves to the bottom right corner of the print range (position1) while the LED is turned off.

Showing Print Area

- After moving, the LED pointer flashes every second, for a total of 3 times.

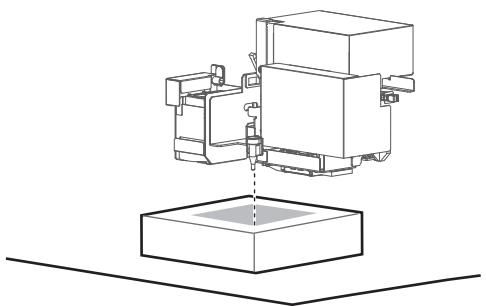



[2]

Position 1 OK? Yes

Check that the LED pointer's position is not misaligned with the media position, and then tap [Enter].



### Note

- The LED pointer remains on until [Enter] is tapped.
- To cancel the job, use  or  to choose "No", then tap [Enter].

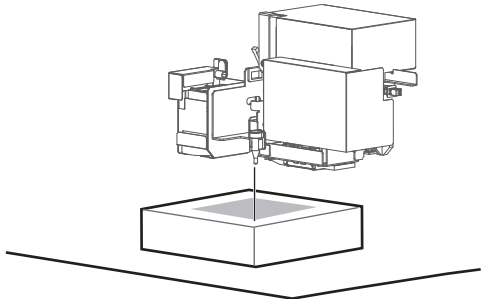

### Showing Print Area

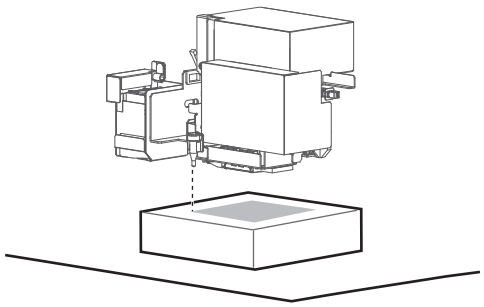

- The LED pointer moves to the bottom left corner of the print range (position2).
- The LED pointer remains on while moving.
- After moving, the LED pointer flashes every second, for a total of 3 times.

#### Note

When the print data's width (CR direction length) is too big for the media, the LED pointer flashes twice a second, for a total of 6 times after moving.

[3]

### Position 2 OK?

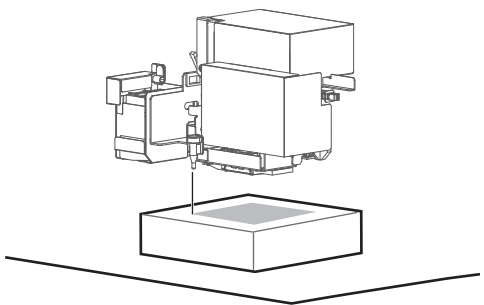

Yes



Check that the LED pointer's position is not misaligned with the media position, and then tap [Enter].



#### Note

- The LED pointer remains on until [Enter] is tapped.
- To cancel the job, use  or  to choose "No", then tap [Enter].

### Showing Print Area

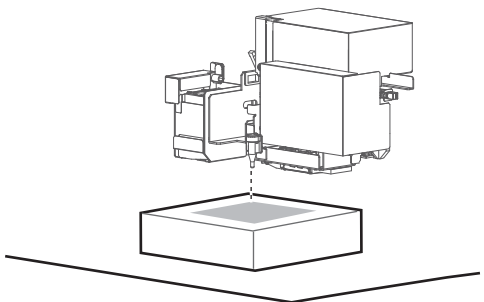

- The LED pointer moves to the top left corner of the print range (position3).
- The LED pointer remains on while moving.
- After moving, the LED pointer flashes every second, for a total of 3 times.

#### Note

When the print data's width (CR direction length) is too big for the media, the LED pointer flashes twice a second, for a total of 6 times after moving.

[4]

### Position 3 OK?

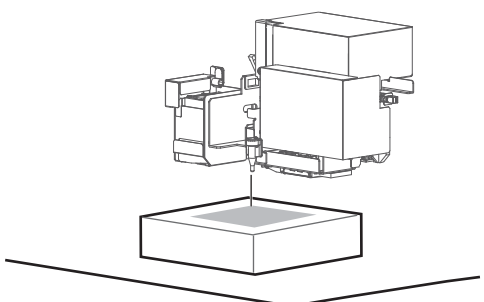

Yes



Check that the LED pointer's position is not misaligned with the media position, and then tap [Enter].



#### Note

- The LED pointer remains on until [Enter] is tapped.
- When the print data's length (PF direction length) is too big for the media, the LED pointer flashes twice a second, for a total of 6 times after moving.
- To cancel the job, use  or  to choose "No", then tap [Enter].

### Showing Print Area

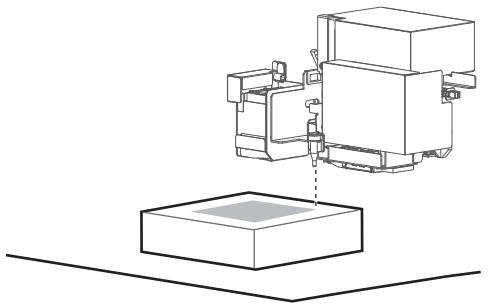

- The LED pointer moves to the top right corner of the print range (position4).
- The LED pointer remains on while moving.
- After moving, the LED pointer flashes every second, for a total of 3 times.

#### Note

When the print data's length (PF direction length) is too big for the media, the LED pointer flashes twice a second, for a total of 6 times after moving.

[5]

### Position 4 OK?

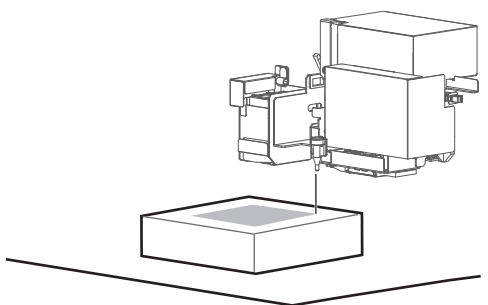

Yes



Check that the LED pointer's position is not misaligned with the media position, and then tap [Enter].



#### Note

- The LED pointer remains on until [Enter] is tapped.
- To cancel the job, use  or  to choose "No", then tap [Enter].

### Showing Print Area

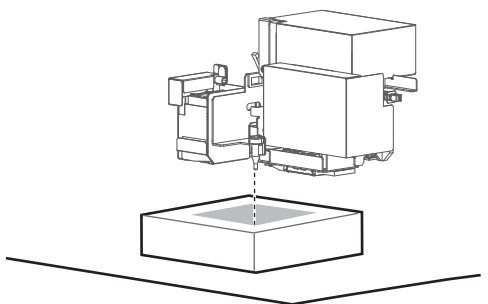

- The LED pointer moves to the bottom right corner of the print range (position1).
- The LED pointer remains on while moving.
- After moving, the LED pointer flashes every second, for a total of 1 time.



### Please Wait

- The carriage returns to the original position (capping station).
- Checking the print range is complete.

[6]

### Start Printing?

No

Use  or  to select "Yes".

- Tap [Enter].



#### Note

To cancel the job, use  or  to choose "No", then tap [Enter].

## Applying additional UV light after printing

If the print does not cure completely, you can apply extra UV curing after printing.

This is useful for the following cases.

- When printing on media that soaks ink, such as a cloth and so on.
- When printing an image that uses a lot of ink.
- When the multi-layered ink on the media is thick.

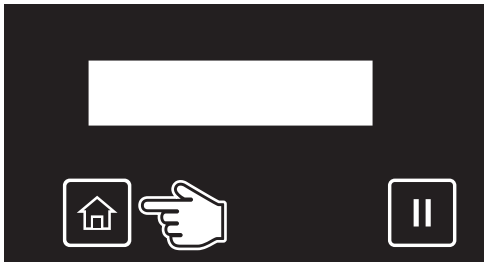

[1]



After printing, tap [Home].



[2]



- Use  to choose the menu shown left.
- Tap .

[3]



- Use  to choose the menu shown left.
- Tap .

[4]



Tap .

[5]





Tap [Enter].

- The printer applies UV light on the print.



### Note

- The range to apply the UV light depends on the user type's [MediaSetting] – [Size] and [Origin] settings that are currently selected.
- See the following when changing the number of reciprocating motions for every 1 inch in the media feeding direction while performing UV scanning.  
 ["UV Scan2: Number of Scan" P. 98](#)
- To apply additional UV-LED light automatically every time after printing, see the following.  
 ["UV Scan3: Post Cure" P. 98](#)

For details on the related sections of the Panel Setting menu, see the following.

 ["Maintenance 4: UV Scan" P. 97](#)

## Calibrating table height

To optimize the gap between the print head and media, calibrate the table height position.

This menu helps to correct following symptoms on your print:

- Ink bleeding
- Faint print
- Ink mottling

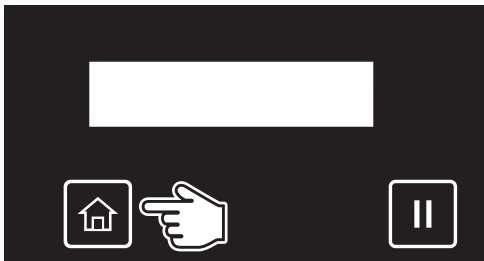

[1]



After printing, Tap [Home].



[2]



- Use  to choose the menu shown left.
- Tap .

[3]



- Use  to choose the menu shown left.
- Tap .

[4]



Tap [Enter].



The message on the left will appear.

- The table moves to the front side of the printer.

[5]



The message on the left will appear.

- Remove the media, and then tap [Enter].



The message on the left will appear.

- The printer starts table height calibration.

[6]



The calibration is now complete.

## Note

If the problem still persists after the calibration, go to following menus to perform printing adjustment and media feeding adjustment.

 **\*\*>2: Adjust Print" P. 66**

 **\*\*>4: PF Adjust" P. 72**

## Important!

When using this product, do not place any object in the table height detection area. This will cause false detection and the printer will not be able to print correctly.

Also, the area in front of the guide groove on the front side of the table is outside the sensing area of the obstacle detection sensor. Do not place any object thicker than the media being loaded in this area. This will cause head strike, leading to damage to the print head.

For details, see the following section:

 **"Printing area" P. 32**

For details on the related sections of the Panel Setting menu, see the following.

 **"Maintenance 7: Calibration" P. 100**

## Layer printing

This printer has the capability for layer printing.

- To perform layer printing using Layout and Print Tool 2 or MUTOH Layer Editor, see Layout and Print Tool 2 Operation Manual or MUTOH Layer Editor Operation Manual.

 **"Displaying Help" P. 17**

- See the following related sections of Panel Setting Menus (Chapter 2 below):

 **\*\*>3: Adjust Layer Print" P. 68**

 **"Advanced Settings 1: Multi Strike" P. 80**

 **"Advanced Settings 8: Multi Layer" P. 85**



# Chapter 2 Advanced Operations

<b>Introduction</b> .....	<b>58</b>
Operating the keys to use the menus .....	58
Panel setup menu .....	60
<b>Menu1: Setup</b> .....	<b>63</b>
Setup 1: User Type .....	63
Setup 2: Advanced .....	79
Setup 3: Initial Settings .....	89
Setup 4: Initialization .....	92
<b>Menu2: Test Print</b> .....	<b>93</b>
Test Print 1: Nozzle Check .....	93
Test Print 2: Nozzle Check B. ....	93
Test Print 3: Mode Print .....	94
Test Print 4: Setup List .....	94
Test Print 5: Palette .....	95
<b>Menu3: Maintenance</b> .....	<b>96</b>
Maintenance 1: Cleaning .....	96
Maintenance 2: Reset Waste Ink .....	97
Maintenance 3: CR Maintenance .....	97
Maintenance 4: UV Scan .....	97
Maintenance 5: Ink Discharge .....	98
Maintenance 6: Plug Life .....	99
Maintenance 7: Calibration .....	100
Maintenance 8: Moving Printer .....	100
Maintenance 9: Table Maintenance .....	100
Maintenance 10: Daily Maintenance .....	101
<b>Menu4: Printer Status</b> .....	<b>102</b>
Printer Status 1: Ink .....	102
Printer Status 2: Lifetimes .....	103
Printer Status 3: Job Status .....	104
Printer Status 4: Version .....	104
Printer Status 5: Serial No. ....	104
Printer Status 6: Total Print Area .....	105
<b>Menu5: Option</b> .....	<b>106</b>
<b>Option 1: Rotary Unit</b> .....	<b>106</b>
<b>Menu6: Sleep Mode</b> .....	<b>107</b>
Sleep Mode1: Start .....	107
Sleep Mode2: Cleaning Timer .....	107
<b>Menu chart</b> .....	<b>108</b>
Setting menu 1 .....	108
Setting menu 2 .....	109
Setting menu 3 .....	110
Setting menu 4 .....	111
Menu during printing .....	111

# Introduction

Using the panel setting menus, configure various kinds of settings for the printer.

## Operating the keys to use the menus

[1] To access to the setup menu, tap [Home].

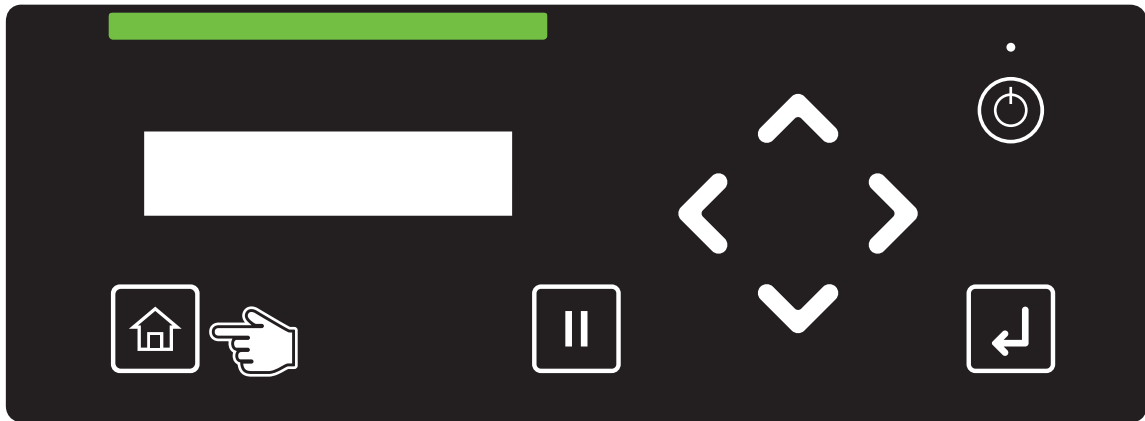

### Note

You cannot access to the setup menu while printing or receiving data (the power button is flashing).

[2]

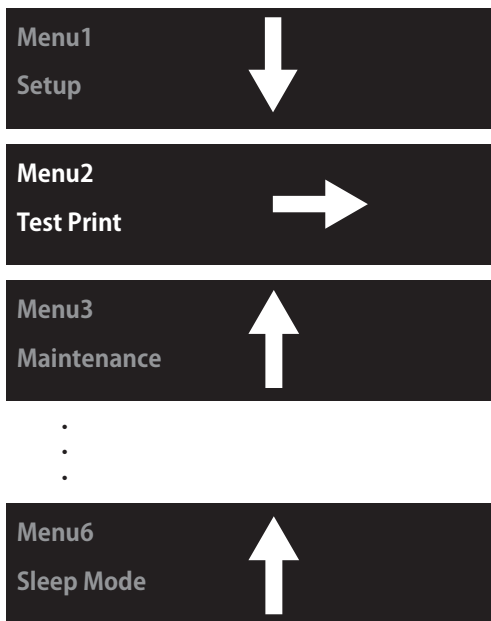

Use or to go to the previous item or next item.





Use to go to the sub menu.

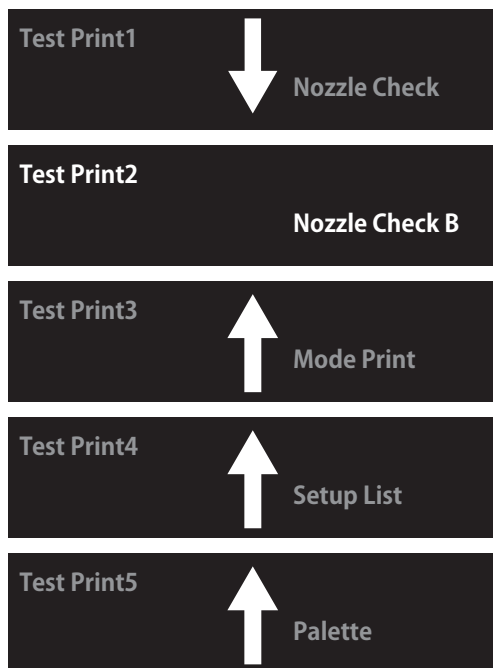

[3]



Use  or  to choose the option from the sub menu or enter the value.



To confirm the value or execute the selected function, tap [Enter].



Use  to return to the upper level menu.  
(In the example on the left, the display will return to "Menu2: Test Print".)



## Panel setup menu

### Menu 1: Setup

Menu 1  
Setup

Configure printer settings.

#### Submenus

Setup1  
User Type

 [Setup 1: User Type](#)

Setup2  
Advanced Settings

 [Setup 2: Advanced](#)

Setup3  
Initial Settings

 [Setup 3: Initial Settings](#)

Setup4  
Initialization

 [Setup 4: Initialization](#)

### Menu 2: Test Print

Menu2  
Test Print

Performs nozzle check of the print head and prints a printer setup list.

#### Submenus

Test Print1  
Nozzle Check

 [Test Print 1: Nozzle Check](#)

Test Print2  
Nozzle Check B

 [Test Print 2: Nozzle Check B](#)

Test Print3  
Mode Print

 [Test Print 3: Mode Print](#)

Test Print4  
Setup List

 [Test Print 4: Setup List](#)

Test Print5  
Palette

 [Test Print 5: Palette](#)



Note

“Nozzle Check B” will only appear in the menu if 6-color is set.

## Menu 3: Maintenance

---

Menu3  
Maintenance

Performs maintenance for print head and ink.

---

### Submenus

---

Maintenance1  
Cleaning

 [Maintenance 1: Cleaning](#)

Maintenance2  
Reset Waste Ink

 [Maintenance 2: Reset Waste Ink](#)

Maintenance3  
CR Maintenance

 [Maintenance 3: CR Maintenance](#)

Maintenance4  
UV Scan

 [Maintenance 4: UV Scan](#)

Maintenance5  
Ink Discharge

 [Maintenance 5: Ink Discharge](#)

Maintenance6  
Plug Life

 [Maintenance 6: Plug Life](#)

Maintenance7  
Calibration

 [Maintenance 7: Calibration](#)

Maintenance8  
Moving Printer

 [Maintenance 8: Moving Printer](#)

Maintenance9  
Table Maintenance

 [Maintenance 9: Table Maintenance](#)

Maintenance10  
Daily Maintenance

 [Maintenance 10: Daily Maintenance](#)

## Menu 4: Printer Status

Menu4  
Printer Status

Provides printer status information.

### Submenus

Printer Status1  
Ink

 [Printer Status 1: Ink](#)

Printer Status2  
Life Times

 [Printer Status 2: Lifetimes](#)

Printer Status3  
Job Status

 [Printer Status 3: Job Status](#)

Printer Status4  
Version

 [Printer Status 4: Version](#)

Printer Status5  
Serial No.

 [Printer Status 5: Serial No.](#)

Printer Status6  
Total Print Area

 [Printer Status 6: Total Print Area](#)

## Menu 5: Option

Menu5  
Option

Use this menu to attach the Rotary Unit (option).  
For more details of this menu, see the Rotary Unit Operation Manual.

### Submenus

Option1  
Rotary Unit

 [Option 1: Rotary Unit](#)

## Menu 6: Sleep Mode

Menu6  
Sleep Mode

Configures or activates sleep modes.

### Submenus

Sleep Mode1  
Start

 [Sleep Mode1: Start](#)

Sleep Mode2  
Cleaning Timer

 [Sleep Mode2: Cleaning Timer](#)

# Menu1: Setup

## Setup 1: User Type

The User Type is one of user-settings to set media types and printing conditions for printing.

Setup1  
User Type

You can have up to 10 groups of User Type, labeled "Type1" to "Type10". When you select a User Type group ("Type") and tap [Enter], that definition group will be set for the printer. Also, a submenu will be displayed.

### Setting values

User Type:  
Type1



Select a "Type" number, from "Type1" to "Type10".

### Important!

When you have changed to another User Type, all the settings that are alterable via the User Type will be changed to the values in the currently selected User Type.

- When the "media setting" for the user type settings have been changed, the settings for the "media height", "obstacle detect", "media size" and "origin position" are changed to the settings of the selected user type. That means the print start position will also change. Make sure that the printer will start printing from the intended position. If not, the printer could print onto the wrong part(s) of the media or print outside it.

"Detailed-Set: On" (on/off for the set check display when a media is set on the table) only appears when the User Type is selected for the first time. Use  or  to select "On" or "Off", and tap [Enter].

- If you select "Detailed-Set: On", you will have to input the media height, obstacle detect, media size and origin position after tapping  each time you set a media on the table.
- If you select "Detailed-Set: Off", "Ready to Print" will be displayed after tapping  each time you set a media on the table. The currently selected User Type values will be used for the media height, obstacle detect, media size and origin position.
- Even when "Detailed-Set" is set to Off, you can enter media height, obstacle detect, media size and origin position from the "\*\*\*: Media Setting1 Set Media" by tapping [Cancel] while the message "Print Ready" or "Set media then tap [^] key." appears on the panel.

User Type:











Type1

Configures the printer settings for selected User Type.

---

Submenus

---

Type ** : 1 Print Mode	 <b>**&gt;1: Print Mode</b>
Type ** : 2 Adjust Print	 <b>**&gt;2: Adjust Print</b>
Type ** : 3 Adj. Layer Prn.	 <b>**&gt;3: Adjust Layer Print</b>
Type ** : 4 PF Adjust	 <b>**&gt;4: PF Adjust</b>
Type ** : 5 Vacuum Fan	 <b>**&gt;5: Vacuum Fan</b>
Type ** : 6 Media Setting	 <b>**&gt;6: MediaSetting</b>
Type ** : 7 Low Speed	 <b>** &gt; 7: Low Speed</b>
Type ** : 8 Show Edges	 <b>**&gt;8: Show Edges</b>
Type ** : 9 Obstacle Detect	 <b>**&gt;9: Obstacle Detect</b>
Type ** : 10 Copy User Type	 <b>**&gt;10: User Copy</b>
Type ** : 11 Initialization	 <b>**&gt;11: Initialization</b>



## \*\*>1: Print Mode

Type\*\* : 1  
Print Mode

Selects the print mode.

- After setting the print mode, go on to setting of effect.
- The number of passes in the print mode varies between 4-color and 6-color ink configuration. See [Details of print mode](#) for more details.

### Setting values

\*\* : Mode : Fast  
720 × 1080      12 pass      Uni

High-speed printing

\*\* : Mode : Fine  
720 × 1440      16 pass      Uni

This is the default setting.

\*\* : Mode : Super Fine  
1440 × 1440      32 pass      Uni

High-quality printing

## Details of print mode

Print Mode	Color set	Resolution	Pass	Direction	Initial values for effect
Fast	6 Colors	720 × 1080	12pass	Uni (unidirectional)	i-Weave UV
	4 Colors	720 × 1080	6pass	Uni (unidirectional)	i-Weave UV
Fine	6 Colors	720 × 1440	16pass	Uni (unidirectional)	i-Weave UV
	4 Colors	720 × 1440	8pass	Uni (unidirectional)	i-Weave UV
Super Fine	6 Colors	1440 × 1440	32pass	Uni (unidirectional)	i-Weave UV
	4 Colors	1440 × 1440	16pass	Uni (unidirectional)	i-Weave UV

## Effect

\*\* : Mode : Fast  
720 × 1080      12 pass      Uni

Selects the effect.

Set up this menu when you want to improve print quality by adjusting the set print mode.

### Setting values

\*\* : Effect :  
None

The Effect function is not applied.

\*\* : Effect :  
i-Weave UV

The printing joint will shade off.  
This is the default setting.

## \*\*>2: Adjust Print

Type \*\*: 2  
Adjust Print

Adjusts the printer to optimize the print quality for the media.

- Required media size: width 210 mm x length 100 mm.

 ["Confirm pattern" P. 88](#)

 ["Rough adjustment pattern" P. 67](#)

 ["Fine adjustment pattern" P. 67](#)

### Submenus

** : Adjust Print1 Confirm Pattern	Print a confirm pattern.
** : Adjust Print2 Rough Pattern ALL	Print rough adjustment patterns A to C and enter adjustment values.
** : Adjust Print3 Rough Pattern A	Print rough adjustment pattern A only and enter an adjustment value.
** : Adjust Print4 Rough Pattern B	Print rough adjustment pattern B only and enter an adjustment value.
** : Adjust Print5 Rough Pattern C	Print rough adjustment pattern C only and enter an adjustment value.
** : Adjust Print6 Fine Pattern ALL	Print fine adjustment patterns A to C and enter adjustment values.
** : Adjust Print7 Fine Pattern A	Print fine adjustment pattern A only and enter an adjustment value.
** : Adjust Print8 Fine Pattern B	Print fine adjustment pattern B only and enter an adjustment value.
** : Adjust Print9 Fine Pattern C	Print fine adjustment pattern C only and enter an adjustment value.

### Steps



1. Print a confirm pattern and check it for printing errors.
2. Print rough adjustment patterns and enter correction values.
  - Select "ALL", or one of "A" to "C".
3. Print fine adjustment patterns and enter correction values.
  - Select "ALL", or one of "A" to "C".

## Confirm pattern

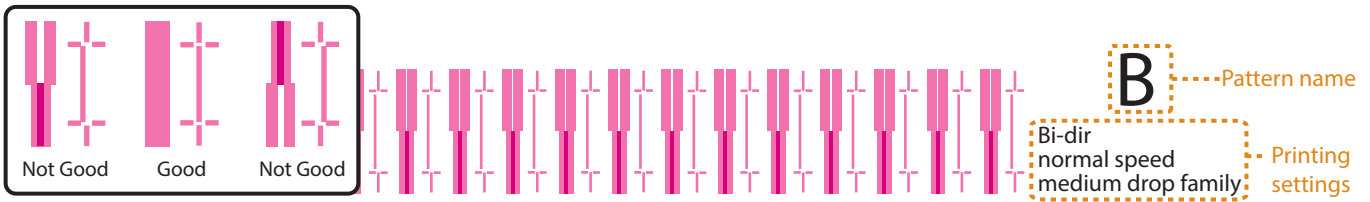
- Tap [Enter] to carry out printing.
- Check the pattern print. If there are misalignments, proceed to rough adjustment pattern printing.
- In the picture below, there are misalignments.



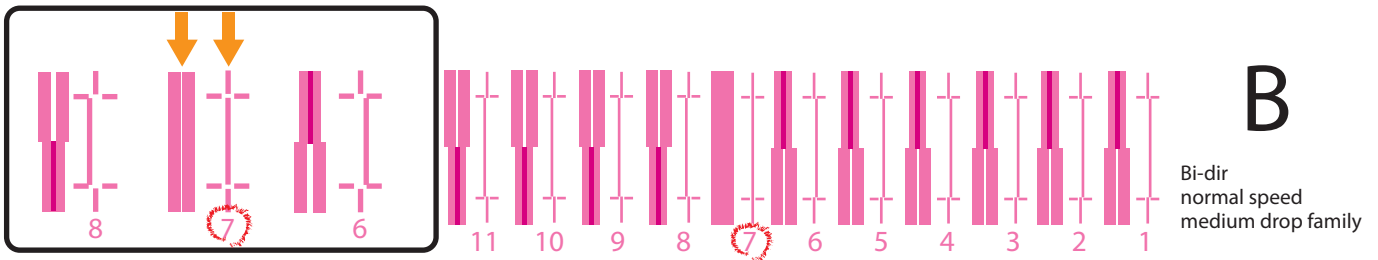

## Rough adjustment pattern

- Tap [Enter] to carry out printing.
- Look for and mark a number printed under a pattern that has least misalignment.
- "Pattern B: 6" or similar will appear in the display. Use  or  to enter in the display the number that you marked, and tap [Enter].
- In the case of the picture below, enter "7", so that the display reads "Pattern B: 7".



## Fine adjustment pattern

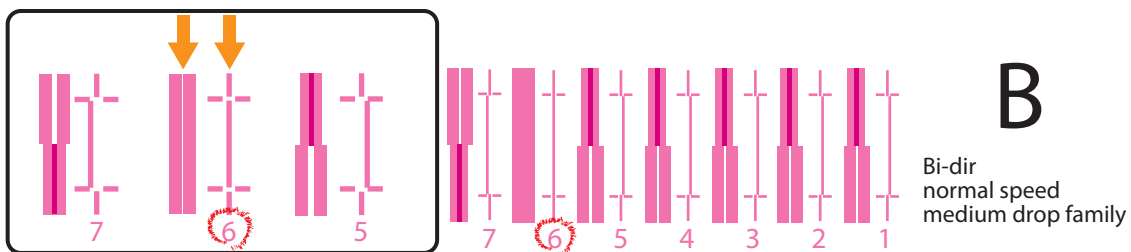

- Tap [Enter] to carry out printing.
- Look for and mark a number printed under a pattern that has least misalignment.
- "Pattern B: 4" or similar will appear in the display. Use  or  to enter in the display the number that you marked, and tap [Enter].
- In the case of the picture below, enter "6", so that the display reads "Pattern B: 6".



## \*\*>3: Adjust Layer Print

Type \*\*: 3  
Adj. Layer Prn.

Use this option when you want to correct layer shifting.

- Required media size: width 210 mm x length 100 mm.
- "Adj. Layer Prn." menu only appears for printer with 6-color configuration.
- The menus "Adj. Layer Prn.1" through "Adj. Layer Prn.5" are used for white layer alignment to correct white layer shifting in single-layer or multi-layer printing.  
 ["Procedure for white layer alignment" P. 69](#)
- If layer shifting still occurs in multi-layer printing after performing white layer alignment, perform layer alignment using the menus "Adj. Layer Prn.6" through "Adj. Layer Prn.12". This will correct misalignment between layers in multi-layer printing.  
 ["Procedure for layer alignment" P. 70](#)

### Submenus

** : Adj. Layer Prn. 1 Wh Confirm Pattern	Print a white confirm pattern.
** : Adj. Layer Prn. 2 White Pattern ALL	Print white adjustment patterns A to C and enter adjustment values.
** : Adj. Layer Prn. 3 White Pattern A	Print white adjustment pattern A only and enter an adjustment value.
** : Adj. Layer Prn. 4 White Pattern B	Print white adjustment pattern B only and enter an adjustment value.
** : Adj. Layer Prn. 5 White Pattern C	Print white adjustment pattern C only and enter an adjustment value.
** : Adj. Layer Prn. 6 Layer Confirm Ptn.	Print a layer confirm pattern.
** : Adj. Layer Prn. 7 Layer Rough Ptn. ALL	Print rough layer adjustment patterns B to C and enter adjustment values.
** : Adj. Layer Prn. 8 Layer Rough Ptn. B	Print rough layer adjustment pattern B only and enter an adjustment value.
** : Adj. Layer Prn. 9 Layer Rough Ptn. C	Print rough layer adjustment pattern C only and enter an adjustment value.
** : Adj. Layer Prn. 10 Layer Fine Ptn. ALL	Print fine layer adjustment patterns B to C and enter adjustment values.
** : Adj. Layer Prn. 11 Layer Fine Ptn. B	Print fine layer adjustment pattern B only and enter an adjustment value.
** : Adj. Layer Prn. 12 Layer Fine Ptn. C	Print fine layer adjustment pattern C only and enter an adjustment value.

## Procedure for white layer alignment

1. Print a white confirm pattern and check it for printing errors.
2. Print white adjustment patterns and enter correction values.
  - Select "ALL", or one of "A" to "C".

### White confirm pattern



- Tap [Enter] to carry out printing.
- Check the pattern print. If there are misalignments, proceed to white adjustment pattern printing.
- In the picture below, there are misalignments.



### Note

The figure above is an example of the white adjustment B pattern. In this example, non-colored background area is shown in gray.

### White adjustment pattern

- Tap [Enter] to carry out printing.
- Look for and mark a number printed under a pattern that has least misalignment.
- "Pattern B: 4" or similar will appear in the display. Use  or  to enter in the display the number that you marked, and tap [Enter].
- In the case of the picture below, enter "6", so that the display reads "Pattern B: 6".



## Procedure for layer alignment

1. Print a layer confirm pattern and check it for printing errors.
2. Print rough layer adjustment patterns and enter correction values.
  - Select "ALL", or one of "B" to "C".
3. Print fine adjustment patterns and enter correction values.
  - Select "ALL", or one of "B" to "C".

### Layer confirm pattern

- Tap [Enter] to carry out printing.
- Check the pattern print. If there are misalignments, proceed to rough layer adjustment pattern printing.
- In the picture below, there are misalignments.



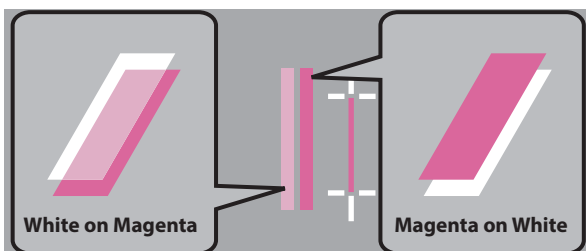

### Note

- The figure above is an example of the layer adjustment B pattern. In this example, non-colored background area is shown in gray.
- Two types of layer patterns are printed; "White on Magenta" prints a white layer over a magenta layer and "Magenta on White" prints a magenta layer over a white layer.



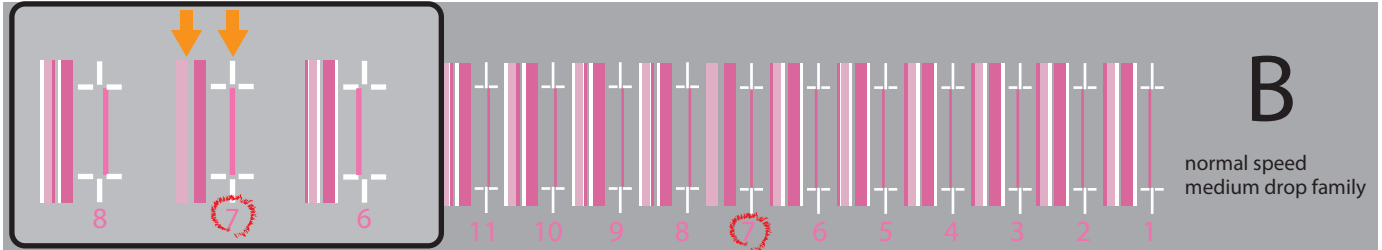

### Rough layer adjustment pattern

- Tap [Enter] to carry out printing.
- Look for and mark a number printed under a pattern that has least misalignment.
- "Pattern B: 6" or similar will appear in the display. Use  or  to enter in the display the number that you marked, and tap [Enter].
- In the case of the picture below, enter "7", so that the display reads "Pattern B: 7".



### Fine layer adjustment pattern

- Tap [Enter] to carry out printing.
- Look for and mark a number printed under a pattern that has least misalignment.
- "Pattern B: 4" or similar will appear in the display. Use  or  to enter in the display the number that you marked, and tap [Enter].
- In the case of the picture below, enter "6", so that the display reads "Pattern B: 6".

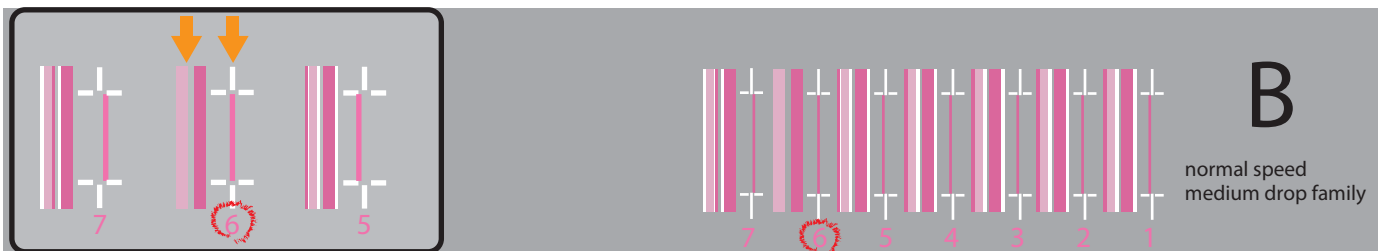

## \*\*>4: PF Adjust

Type \*\*: 4  
PF Adjust

Performs media feed adjustment.

- Required media size: width 210 mm x length 110 mm.
- A ruler is required for this adjustment. Please prepare a commercially available ruler.

When the following defects are found in your prints, they may improve by conducting a paper feed correction.

- Images are overlapping.
- There are white lines in images.

---

### Submenus

---

\*\* : PF Adjust1  
Initial Print

 ["PF 1. Initial Print" P. 73](#)

\*\* : PF Adjust2  
Initial Change

 ["PF2. Initial Change" P. 73](#)

\*\* : PF Adjust3  
Confirm Print

 ["PF3. Confirm Print" P. 74](#)

\*\* : PF Adjust4

Micro Print

 ["PF4. Micro Print" P. 74](#)

\*\* : PF Adjust5  
Micro Change

 ["PF5. Micro Change" P. 75](#)

## Steps

1. Determine the feed length for the "PF1 Initial Print", print it, and measure the distance between the "+" marks with a ruler.
2. Enter the distance measured as the "PF2 Initial Change".
3. Determine the feed length for the "PF3 Confirm Print", print it, and measure the distance between the "+" marks with a ruler.
  - Check that there is no deviation from the feed length.
4. Print a "PF4 Micro Print", and find the pattern with the least white streaks and image overlaps.
  - The numeral below that pattern is the micro adjustment value.
5. Enter the micro adjustment value according to the test pattern print in Step 4.

## When you know the adjustment value (when changing the media or for similar operations)

1. Enter the adjustment value for "PF Adjust 5: Micro Change".



## PF 1. Initial Print

\*\* : PF Adjust1  
Initial Print

Performs initial adjust print. Enter the "FeedLength", and tap [Enter].  
Print a "+" mark at the beginning, feed the media according to the setting value, and print another "+" mark.

---

### Setting values

---

\*\* : Initial Print  
FeedLength : 250 mm

100 mm to <250 mm> to 550 mm  
<> indicates the default setting.

- With a ruler, measure the length between "+" in the pattern.
- In the example below, the measured place is shown in blue dotted lines and arrows (the blue parts are not actually printed).

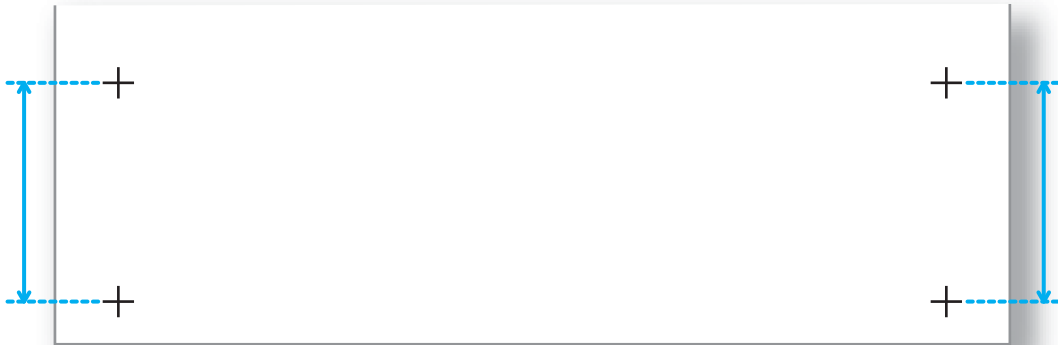



### Important!

- The maximum setting value for the feed length will vary depending on the settings for "MediaSetting", "Size" and "Length" in the User Type. (The same applies to "Confirm Print".)
- Some media lengths cannot be used.  
For example, if a media has a length of 100 mm or below, "Media size error: Length" will appear on the panel and printing will not be carried out.

## PF2. Initial Change

\*\* : PF Adjust2  
Initial Change

Use  or  to enter the adjustment value, and tap [Enter].

---

### Setting values

---

\*\* : Initial Change  
Init. : 260 mm / 250 mm

<Initial Print menu setting value>  
± 10.0 mm  
<> indicates the default setting.

### PF3. Confirm Print

\*\* : PF Adjust3  
Confirm Print

Performs Confirm Print. Enter the "FeedLength", and tap [Enter].  
Print a "+" mark at the beginning, feed the media according to the setting value, and print another "+" mark.

#### Setting values

\*\* : Confirm Print  
FeedLength : 250 mm

100 mm to <250 mm> to 550 mm  
<> indicates the default setting.

- With a ruler, measure the length between "+" in the pattern.
- If there is discrepancy between the value set for "FeedLength" and the value measured, carry the procedure out again from 1. "Initial Print". If there is no discrepancy, go to 4. "PF4. Micro Print".
- In the example below, the measured place is shown in blue dotted lines and arrows (the blue parts are not actually printed).

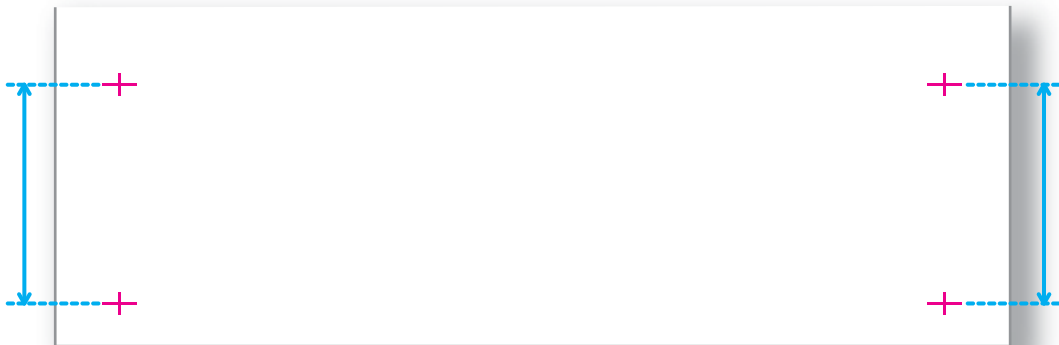

### PF4. Micro Print

\*\* : PF Adjust4  
Micro Print

Performs Micro adjustment print.  
Enter the appropriate micro adjustment value according to the test pattern print.

- Observe the pattern and verify the micro adjustment value. In the pattern, look for a place that has least white lines or overlapping in images. The number printed below the pattern is the micro adjustment value.
- Enter the Micro adjustment value according to the test pattern print.

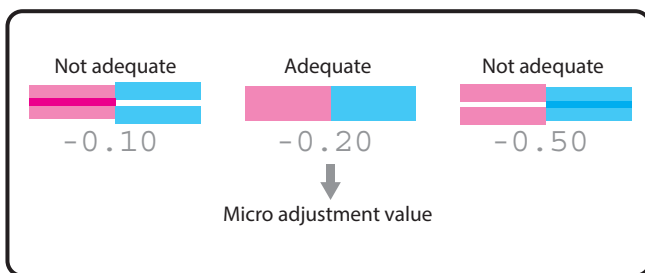



#### Note

The micro adjustment value saved becomes the pattern's standard value.

For example, if "-0.20" is saved as the micro adjustment value and a pattern is printed again, the number below the center pattern changes from "0.00" to "-0.20", and the left edge to "+0.30" and right edge to "-0.70".

## PF5. Micro Change

\*\* : PF Adjust5  
Micro Change

Use  or  to enter the micro adjustment value, and tap [Enter].

---

### Setting values

---

\*\* : Micro Change  
(-5 - 5)                      0.00%

-5.00% to <0.00%> to 5.00%  
<> indicates the initial value.

## \*\*>5: Vacuum Fan

Type \*\* : 5  
Vacuum Fan

Sets up vacuum fan operation. It has the role of fixing the media to the table.

- If you are using a thin or delicate media and there is risk of it wrinkling due to the fan, set a lower value for the fan.
- If you are not using the optional vacuum table on the printer, this menu does not appear on the panel. The rest of the menus will be displayed with a different menu number.

---

### Setting values

---

\*\* : Vacuum Fan :                      High

<High> / Medium-Hi / Medium / Low / Off  
<> indicates the default setting.

\*\* : Vacuum Fan :                      Medium-Hi

\*\* : Vacuum Fan :                      Medium

\*\* : Vacuum Fan :                      Low

\*\* : Vacuum Fan :                      Off

## \*\*>6: MediaSetting

Type \*\* : 6  
Media Setting

This is for setting the conditions for placing the media on the table.

---

### Submenus

---

\*\* : Media Setting1  
Set Media

For entering the media width and length, and setting the origin position.

- Carry these out with the media set in place on the table.

 ["Loading media" P. 33](#)

\*\* : Media Setting2

Size

For entering the media width and length only.

 ["Inputting the media width, length and the origin position" P. 36](#), Step 1 and Step 2.

\*\* : Media Setting3

Height

Select Auto or Manual to determine the table height and specify the printer response when detecting obstacle while printing.

 ["Media Height Setting & Printer Response Setting for Obstacle Detection" P. 35](#)

\*\* : Media Setting4

Origin

Enter the origin of the job.



 ["Inputting the media width, length and the origin position" P. 36](#), Step 3 and Step 4.

\*\* : Media Setting5

Detailed-Set

Off / <On>

<> indicates the default setting.

- If you select "Detailed-Set: On", you will have to input the media height, obstacle detect, media size and origin position after tapping  each time you set a media on the table. However, you can eliminate the need for such input by tapping the [Cancel]. If you do so, the values set in the User Type will be used.
- If you select "Detailed-Set: Off", "Ready to Print" will be displayed after tapping  each time you set a media on the table.  
The currently selected User Type values will be used for the media height, obstacle detect, media size and origin position.
- Even when "Detailed-Set" is set to Off, you can enter media height, obstacle detect, media size and origin position from the "\*\*: Media Setting1 Set Media" by tapping [Cancel] while the message "Print Ready" or "Set media then tap [^] key." appears on the panel.

\*\* : Media Setting5

Obst. Check Mode

Select the detection accuracy of the obstacle sensor when loading media into the printer.

If printing fails due to failure to detect media warp with "Normal" mode, try "High-Accuracy" mode.

Normal / <High-Accuracy>

<> indicates the default setting.

## \*\* > 7: Low Speed

Type\*\* :7  
Low Speed

Use this when you want a slower printing speed.

- It helps to enhance print quality when you print on an uneven surface media or curved object (e.g. golf ball, ballpoint pen, smart phone case).

### Setting values

** : Low Speed: Off	The printing speed will not be lowered. This is the default setting.
** : Low Speed: 75%	The printing speed will be lowered to 75%.
** : Low Speed: 50%	The printing speed will be lowered to 50%.
** : Low Speed: 25%	The printing speed will be lowered to 25%.

## \*\* > 8: Show Edges

Type\*\* :8  
Show Edges

To check the printing area before printing, LED pointer shows where the image will be printed on the media.

 ["Checking the printing area" P. 49](#)

### Setting values

** : Show Edges: Off	LED pointer does not show the printing area. This is the default setting.
** : Show Edges: Step	LED pointer shows where the image will be printed on the media and the printer will ask you at each point of corner if the position is OK.
** : Show Edges: Auto	LED pointer shows where the image will be printed on the media without checking with the user.

## \*\*>9: Obstacle Detect

Type\*\* :9  
Obstacle Detect

Selects the printer operation when the obstacle sensor has detected an obstacle.

### Submenus

\*\* : Obstacle Detect:  
Auto

The printer pause the printing. It lowers the table until the sensor does not detect any obstacle, and then resumes the job. This is the default setting.



#### Note

If the sensor still detects the obstacle after the table moves down to its lowest position, the printer cancels printing and prompts the obstacle error message.

\*\* : Obstacle Detect:  
Print Cancel

The printer cancels printing and prompts the obstacle error message. This is the default setting.

\*\* : Obstacle Detect:  
Confirm

The printer pauses the printing and allows users to choose from two options; Print Continue or Print Cancel.



#### Note

- "Obstacle Detected Print Continue"  
Hold the media flat on the table without any warp, fold or curl.  
Tap [Enter] to resume the job.
- "Obstacle Detected Print Cancel"  
Tap [Enter] to cancel the job and prompts the obstacle error message.

## \*\*>10: User Copy

Type\*\* :10  
Copy User Type

This is for copying the currently selected User Type setting into another User Type.

- The items that will be copied are: "Print Mode", "Effect", "Adjust Print", "Adjust Layer Print" and "PF Adjust" adjustment values, "Vacuum Fan", "Media Setting", "Low Speed", "Show Edges" and "Obstacle Detect".

### Setting values

\*\* : Copy Use Type:  
Type\*\*-> 1

Here you can select the User Type to copy the settings into. If you select ALL, the settings will be copied into all the User Type.

\*\* : Copy Use Type:  
Type\*\*->ALL

## \*\*>11: Initialization

Type\*\* :11  
Initialization

Returns all settings of the currently selected User Type to factory default.

## Setup 2: Advanced

Setup2  
Advanced Setting

Configures various advanced settings.

---

### Submenus

---

Advanced Settings1  
Multi Strike

 ["Advanced Settings 1: Multi Strike" P. 80](#)

Advanced Settings2  
Pass Wait

 ["Advanced Settings 2: Pass Wait" P. 81](#)

Advanced Settings3  
Head Travel

 ["Advanced Settings 3: Head Travel" P. 81](#)

Advanced Settings4  
Header Dump

 ["Advanced Settings 4: Header Dump" P. 82](#)

Advanced Settings5  
Spitting

 ["Advanced Settings 5: Spitting" P. 83](#)

Advanced Settings6  
Cleaning Type

 ["Advanced Settings 6: Cleaning Type" P. 83](#)

Advanced Settings7  
Auto Cleaning

 ["Advanced Settings 7: Auto Cleaning" P. 84](#)

Advanced Settings8  
Multi Layer

 ["Advanced Settings 8: Multi Layer" P. 85](#)

Advanced Settings9  
Ink Maintenance

 ["Advanced Settings 9: Ink Maintenance" P. 86](#)

Advanced Settings10  
Select Nozzle

 ["Advanced Settings 10: Select Nozzle" P. 87](#)

## Advanced Settings 1: Multi Strike

Advanced Settings1  
Multi Strike

Sets the number of times to print the same line.

- The display will shift to setting of layer printing number of strikes only when "Strike Cnt" is set to 1 in 6-color configuration.

### Setting values

Multi Strike:  
(1-9) 1cnt

<1 times> to 9 times  
<> indicates the default setting.

## Layer Multi Strike

Multi Strike:  
(1-9) 1cnt

The display will shift to layer selection.

### Submenus

Layer Multi Strike1  
Color Layer

 [Layer Multi Strike1: Color Layer](#)

Layer Multi Strike2:  
White Layer

 [Layer Multi Strike2: White Layer](#)

Layer Multi Strike3:  
Varnish Layer

 [Layer Multi Strike3: Varnish Layer](#)

## Layer Multi Strike1: Color Layer

Layer Multi Strike1  
Color Layer

Sets the number of times to print the same line in color (CMYK) layer.

### Setting values

Color Layer:  
(1-9) 1cnt

<1 times> to 9 times  
<> indicates the default setting.

## Layer Multi Strike2: White Layer

Layer Multi Strike2:  
White Layer

Sets the number of times to print the same line in white layer.

### Setting values

White Layer:  
(1-9) 1cnt

<1 times> to 9 times  
<> indicates the default setting.



## Layer Multi Strike3: Varnish Layer

Layer Multi Strike3:  
Varnish Layer

Sets the number of times to print the same line in varnish layer (clear topcoat).

---

### Setting values

---

Varnish Layer:  
(1-9) 1cnt

<1 times> to 9 times  
<> indicates the default setting.

## Advanced Settings 2: Pass Wait

Advanced Settings2  
Pass Wait

Sets the waiting time between passes in multi-strike setting and normal printing.

---

### Setting values

---

Pass Wait:  
(0.0-5.0) 5.0sec

<0.0 sec.> to 5.0 sec.  
<> indicates the default setting.

## Advanced Settings 3: Head Travel

Advanced Settings3  
Head Travel

Sets up the range that print head moves while printing.

---

### Setting values

---

Head Travel:  
Data

Print head moves the range of the print data width.

Head Travel:  
Machine

- The print head will travel the maximum distance possible with the printer.

Head Travel:  
Media

Print head shifts within the media width. This is the default setting.

## Advanced Settings 4: Header Dump

---

**Advanced Settings4**  
**Header Dump**

Sets whether to print the following information when printing.  
(Required media size: width 250 mm x length 50 mm.)

- Data header
- Data dot number (printed only when Header Dump setting is ON)
- Printer serial number
- Firmware version

---

### Setting values

---

<b>Header Dump:</b> <b>Off</b>	Dump data is not printed. This is the default setting.
<b>Header Dump:</b> <b>On</b>	Dump data is printed after the original image is printed.
<b>Header Dump:</b> <b>Dump</b>	Prints only header dump. "Data dot number" is not printed.

 **Note**

- The data will be useful when contacting technical support.
- Performing printing if the printer is connected to PC, the print settings of RIP soft you are using are printed on data header.

## Advanced Settings 5: Spitting

### Advanced Settings5 Spitting

Enables or disables the spitting function while printing.

- The display will shift to setting of the pass count only if "On" is set for "Spitting".

#### Setting values

Spitting:  
On

Off / <On>

<> indicates the default setting.



#### Note

Spitting is a maintenance operation for preventing clogging of the print head's nozzles. It consumes ink.

## Pass Count

Spitting:  
On

Sets the frequency that the printer spits ink from the print head.

- The head will carry out spitting operation every time it completes the number of passes that you set here.

#### Setting values

Pass Count:  
(1-999) 1cnt

<1 time> to 999 times

<> indicates the default setting.



#### Important!

**If the number of spitting returns is set high, there is a higher chance of nozzle clogging when printing for a long time. In such a case, print quality cannot be guaranteed.**

## Advanced Settings 6: Cleaning Type

### Advanced Settings6 Cleaning Type

Configure the settings for the auto cleaning (standby mode, during printing, before print) and cleaning while in sleep mode.

#### Setting values

Cleaning Type:  
Short

Consumes less ink than Normal cleaning.

Cleaning Type:  
Normal

Conduct nozzle check before and after printing, and use when nozzle missing is found.

Cleaning Type:  
Long

Consumes more ink than Normal cleaning. When nozzle missing still occurs after Normal cleaning, conduct Long cleaning.

## Advanced Settings 7: Auto Cleaning

### Advanced Settings7 Auto Cleaning

Set the auto cleaning to be performed while in standby mode, during printing, before print, and by total print time.

#### Submenus

Auto Cleaning1  
Standby Mode

 [Standby mode](#)

Auto Cleaning2  
While Printing

 [While Printing](#)

Auto Cleaning3  
Before Print

 [Before Print](#)

Auto Cleaning4  
Accum. Print Time

 [Accum. Print Time](#)

### Standby mode

#### Auto Cleaning1 Standby Mode

Set the timer for auto cleaning to be performed while in standby mode.

#### Setting values

Cleaning Interval:  
(10-1440) 1440min

<Off> / 10 min. to 1,440 min.  
<> indicates the default setting.

### While Printing

#### Auto Cleaning2 While Printing

Set the timer for auto cleaning to be performed while printing.

#### Setting values

Cleaning Interval:  
(5-180) 180min

<Off> / 5 min. to 180 min.  
<> indicates the default setting.

### Before Print

#### Auto Cleaning3 Before Print

Enables or disables auto cleaning before printing.

#### Setting values

Before Print:  
Off

<Off> / On  
<> indicates the default setting.

## Accum. Print Time

Auto Cleaning4  
Accum. Print Time

Set the timer for auto cleaning to be performed by total print time. The auto cleaning is performed before printing by timer.

---

### Setting values

---

Accum. Print Time:  
(1-4) 4h

<Off> / 1h / 2h / 3h / 4h  
<> indicates the default setting.



#### Note

The auto cleaning mode for "Accum. Print Time" is fixed to "Long" and is unable to be changed.

## Advanced Settings 8: Multi Layer

Advanced Settings8  
Multi Layer

Enables or disables to print more than one image data on the same media layer by layer.

---

### Setting values

---

Multi Layer:  
Off

<Off> / On  
<> indicates the default setting.



#### Note

- If you select "Off", the printer will ask you to remove media after printing one data and load a new media to print next data.
- If you select "On", just sending the next data to the printer, you can print more than one data on the same area of the media.
  - For "Adjust Print", "Adj. Layer Prn.", "PF Adjust" and "Test Print", you have to load a media each time when performing a test / pattern printing.

## Advanced Settings 9: Ink Maintenance

### Advanced Settings9 Ink Maintenance

To ensure its performance, the printer runs automatic ink maintenance which spits out some ink when it is used after a certain period of time from the last use.

#### Setting values

Ink Maintenance:  
Normal

Ink maintenance operation will be carried out at a normal frequency. This is the default setting.

Ink Maintenance:  
Light

Ink maintenance operation will be carried out less frequently than Normal mode.

Ink Maintenance:  
Full

More powerful ink maintenance operation than Normal mode will be carried out.

#### Note

Ink (especially white ink) has tendency to settle or coagulate inside the print head or the ink tubes. To prevent this, the printer regularly discharges a small amount of ink even while in ready to print state to maintain its performance.

The maintenance mode available for each ink configuration setting are as follows:

#### • 4-color configuration

Normal	Default setting.
Full	Perform more powerful ink maintenance so that color consistency can be maintained more easily than Normal mode. Use this mode when color inconsistencies appear on the print.

#### • 6-color configuration

Light	If you do not usually use white ink for regular printing, set to "Light" to minimize white ink consumption in standby status. • If you are using white ink, cleaning should be performed as needed to ensure color consistency.
Normal	Default setting.
Full	Perform more powerful ink maintenance so that color consistency can be maintained more easily than Normal mode. Use this mode when color inconsistencies appear on the print.

## Advanced Settings 10: Select Nozzle

---

Advanced Settings10  
Select Nozzle

If missing lines still persist after several attempts of cleaning, you can check the nozzle conditions by printing the select nozzle patterns and choose only good nozzles for printing.

- This feature is disabled for single-layer printing.
- This feature is enabled only when the effect setting is set to "i-Weave UV" or "None".

---

### Setting values

---

Select Nozzle1

Print



["Confirm pattern" P. 88](#)

Select Nozzle2

Nozzle Settings



["Nozzle Settings" P. 88](#)

## Nozzle Settings

Goes to the nozzle settings menu.

Select Nozzle2  
Nozzle Settings

---

### Submenus

---

Nozzle Settings:

Nozzle ALL

<Nozzle All> / Nozzle A to Nozzle D  
<> indicates the default setting.

## Steps



1. Print the select nozzle patterns and find the pattern that does not have missing lines.
2. Go to "Nozzle Settings" and choose the pattern selected in the Step 1.
  - Select "ALL", or one of "A" to "D".

## Confirm pattern

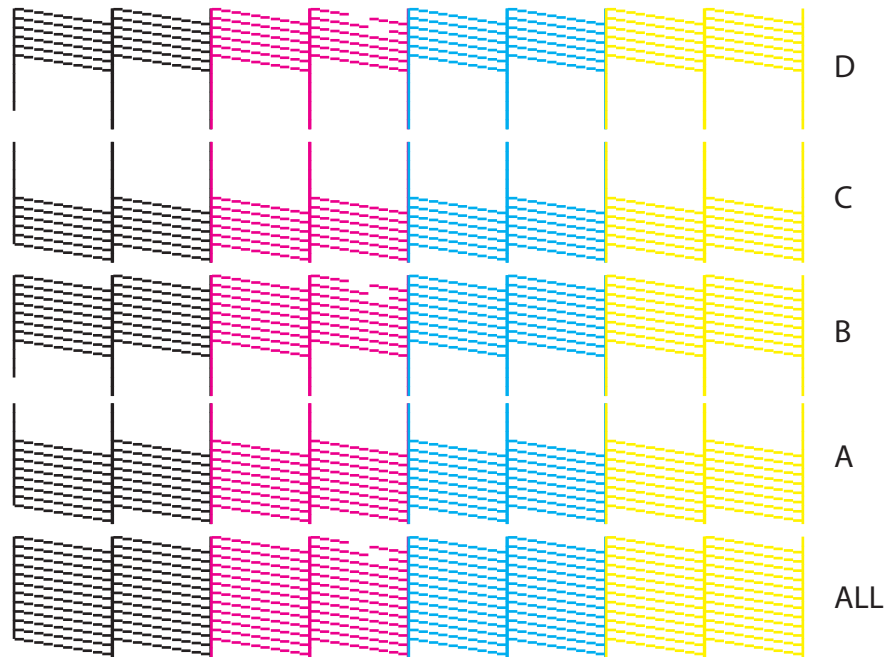
- Tap [Enter] to carry out printing.
- Look at the print and find the pattern that all the lines appear clean.
- In the example here, the pattern A and pattern C do not have missing lines.



## Nozzle Settings

- Tap .
- Use  or  to choose the pattern that does not have missing lines, then tap [Enter].
- If there is more than one patterns not suffering from missing lines, choose the one that has more nozzles available for printing.  
ALL has the most available nozzles for printing, followed by A and B, C and D (More ALL > A = B > C = D Less).  
For example, if the pattern A and pattern C do not suffer from blocked nozzles, you should choose A.



## Setup 3: Initial Settings

Setup3  
Initial Settings

Select a language, unit and IP Address displayed on the LCD.

---

### Submenus

---

Initial Settings1  
Language

 ["Initial Settings 1: Language" P. 90](#)

Initial Settings2  
Length

 ["Initial Settings 2: Length" P. 90](#)

Initial Settings3  
Remain Ink

 ["Initial Settings 3: Remain Ink" P. 91](#)

Initial Settings4  
IP Address

 ["Initial Settings 4: IP Address" P. 91](#)

Initial Settings5  
Subnet Mask

 ["Initial Settings 5: Subnet Mask" P. 91](#)

Initial Settings6  
Gateway

 ["Initial Settings 6: Gateway" P. 92](#)

Initial Settings7  
Alert Buzzer

 ["Initial Settings 7: Alert Buzzer" P. 92](#)

## Initial Settings 1: Language

---

Initial Settings1  
Language

Selects a language to be displayed on the operation panel.

---

### Setting values

---

Language: English

Default setting.

Language: Dutch

Language: Spanish

Language: French

Language: Italian

Language: Portuguese

Language: German

Language: Japanese

## Initial Settings 2: Length

---

Initial Settings2  
Length

Selects a length unit to be displayed on the operation panel.

---

### Setting values

---

Length: mm

Displays the length in millimeters (mm).  
This is the default setting.

Length: inch

Displays the length in inches (inch).

## Initial Settings 3: Remain Ink

---

Initial Settings3  
Remain Ink

Selects how the remaining ink amount will be displayed.

---

### Setting values

Remain Ink: Off

Remaining ink icons will not be displayed. Slot numbers and remaining ink will be displayed in numerals.

Remain Ink: On



Remaining ink icons will be displayed. This is the default setting.

## Initial Settings 4: IP Address

---

Initial Settings4  
IP Address

Sets the IP address of the printer.

- Use  to increase a setting value.
- Use  to decrease a setting value.
- Tap [Enter] to confirm your input for a value. The cursor will move on to the next setting value.
- Confirm your input for each value.

---

### Setting values

IP Address:  
192. 168. 1. 253



0.0.0.0 to <192.168.1.253> to 255.255.255.255  
<> indicates the default setting.

## Initial Settings 5: Subnet Mask

---

Initial Settings5  
Subnet Mask

Sets the subnet mask of the printer.

- Use  to increase a setting value.
- Use  to decrease a setting value.
- Tap [Enter] to confirm your input for a value. The cursor will move on to the next setting value.
- Confirm your input for each value.

---

### Setting values



Subnet Mask:  
255. 255. 255. 0

0.0.0.0 to <255.255.255.0> to 255.255.255.255  
<> indicates the default setting.

## Initial Settings 6: Gateway

Initial Settings6  
Gateway

Sets the gateway.

- Use  to increase a setting value.
  - Use  to decrease a setting value.
  - Tap [Enter] to confirm your input for a value. The cursor will move on to the next setting value.
- Confirm your input for each value.

### Setting values

Gateway:  
192. 168. 1. 254

0.0.0.0 to <192.168.1.254> to  
255.255.255.255  
<> indicates the default setting.

## Initial Settings 7: Alert Buzzer

Initial Settings7  
Alert Buzzer

Selects how to turn off the printer beep sound when an error occurs.

- For unattended printing, you can select "Off" setting to avoid continuous buzzer beep.

### Setting values

Alert Buzzer:  
Off

After several beeps, the printer automatically turns off beep sound.

Alert Buzzer:  
On

Press any key on Operation panel to turn off beep sound.  
This is the default setting.

## Setup 4: Initialization

Setup4  
Initialization

Restore the settings of the printer to factory default.

### Submenus

Initialization1  
User Type ALL

Initialize the User Type settings (Type1 to Type10) in all the submenus of the "**Setup 1: User Type**".

Initialization2  
Advanced Settings

Initialize the settings in all the submenus of the "**Setup 2: Advanced**".

Initialization3  
Initial Settings

Initialize the settings in all the submenus of the "**Setup 3: Initial Settings**".

Initialization4  
ALL

Initialize the settings of all the menus.

# Menu2: Test Print

## Test Print 1: Nozzle Check

Test Print1

Nozzle Check

It is used to check whether there are any clogged heads, or missing or blurred prints.

(Required media size: width 260 mm x length 35 mm.)

["Run a nozzle check print" P. 38](#)

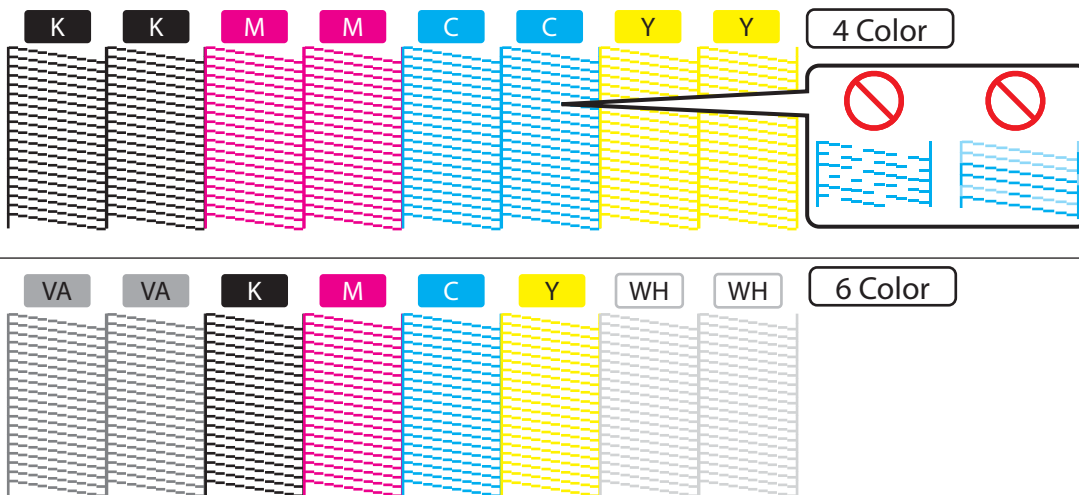

### Note

The printer information (date and time of printing, printer's serial number, firmware version) is printed on the nozzle check pattern.

## Test Print 2: Nozzle Check B

Test Print2

Nozzle Check B

This is nozzle check for white ink.

The background for some of the nozzle check pattern is printed in color so that the nozzle condition is easy to see.

- Part of the background for the white nozzles is black.
  - The background of the KCMY nozzles are white.
  - For varnish (and part of white) nozzles, the background is not printed.
- (Required media size: width 260 mm x length 35 mm.)

["Run a nozzle check print" P. 38](#)

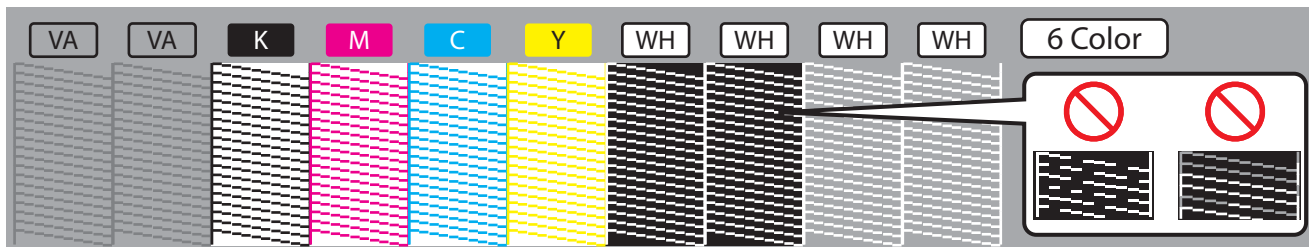

### Note

- "Nozzle Check B" will only appear in the menu if 6-color is set.
- The printer information (date and time of printing, printer's serial number, firmware version) is printed on the nozzle check pattern.

## Test Print 3: Mode Print

Test Print3

Mode Print

Print following settings of the selected User Type configured from the operation panel.

Used to confirm the following printing conditions.

- Print quality
- Effect
- Fine adjustment value for feed correction.

(Required media size: width 220 mm x length 25 mm.)

2019/12/01 0:00 Fine (720x1440 16Pass Uni)-i-Weave UV/PF Adjust: 0.00%



## Test Print 4: Setup List

Test Print4

Setup List

Setup list printing is performed.

Use this to check the current setting contents and the User Type.

(Required media size: width 420 mm x length 297 mm)

### Setup List

### User Type List

<User type List>						
User Type	Type 1	Type 2	Type 3	Type 4	Type 5	Type 6
Print Mode	Print	Print	Print	Print	Print	Print
Print Mode Effect	None	None	None	None	None	None
Print Mode Adjust	250 (1/2000)	250 (1/2000)	250 (1/2000)	250 (1/2000)	250 (1/2000)	250 (1/2000)
Print Mode Adjust	0.0%	0.0%	0.0%	0.0%	0.0%	0.0%
Variable Fax	Normal	Normal	High	Normal	Low	High
Media Color	Color	Color	Color	Color	Color	Color
Media Length	257	257	257	257	257	257
Media Correction	Dr. 0.000%	Dr. 0.000%	Dr. 0.000%	Dr. 0.000%	Dr. 0.000%	Dr. 0.000%
Media Color	Off	Off	Off	Off	Off	Off
Media Color	On	Off	Off	Off	Off	Off
Low Speed	Off	Off	Off	Off	Off	Off

# Test Print 5: Palette

Test Print5

Palette

Palette print is executed for the color demonstration.  
(Required media size: width 210 mm x length 210 mm.)

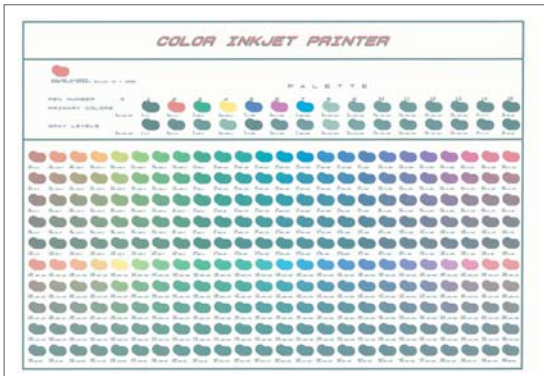

## Maintenance 1: Cleaning

### Maintenance1 Cleaning

Perform Head cleaning.

#### Submenus

##### Cleaning Type1

Short

Consumes less ink than Normal cleaning.

##### Cleaning Type2

Normal

Perform Normal cleaning if nozzle clogging is found in the nozzle check print.

##### Cleaning Type3

Long

Perform Long cleaning if nozzle clogging still persists after performing Normal cleaning. It consumes more ink than Normal cleaning.

##### Cleaning Type4

Little Charge

Provide higher cleaning effect than Long cleaning, but it also consumes more ink.

##### Cleaning Type5

Initial Charge

Provide higher cleaning effect than Little Charge, but it also consumes more ink.

- When "Empty Waste Ink Tank then Tap Enter" appears, empty out the waste ink and tap [Enter].

 ["Drain waste ink into a container" P. 125](#)



## Maintenance 2: Reset Waste Ink

Maintenance2  
Reset Waste Ink

This resets the waste ink counter to zero.

 ["Resetting waste ink counter" P. 127](#)

## Maintenance 3: CR Maintenance

Maintenance3  
CR Maintenance

Use this for replacing absorption material for the flushing box and the cleaning wiper.

 ["Replacing absorption material for the flushing box" P. 147](#)

 ["Replacing the cleaning wiper" P. 151](#)

 ["Replacing the Emitting Window Glass on the UV-LED Lamp" P. 154](#)

 ["Replacing UV-LED Lamp Filter" P. 157](#)

### Submenus

CR Maintenance  
Start → Enter

Tap [Enter] to replace the absorption material for the flushing box.

- The carriage moves to the center of the printer.
- The cleaning wiper moves upward.

CR Maintenance  
End → Enter

After the replacement is complete, tap [Enter].

- The printer moves the carriage and the cleaning wiper back to each original position.

## Maintenance 4: UV Scan

Maintenance4  
UV Scan

Performs further UV curing.

Use this when you want to promote ink curing by applying additional UV light.

### Submenus

UV Scan1  
Start

 [UV Scan1: Start](#)

UV Scan2  
Number of UV Scan

 [UV Scan2: Number of Scan](#)

UV Scan3  
Post Cure

 [UV Scan3: Post Cure](#)



### Note

The range over which the UV scanning is executed will depend on the current settings for "Size" and "Origin" in the "MediaSetting" User Type.

## UV Scan1: Start

UV Scan1  
Start

Performs further UV curing when needed.

When the media is not loaded, "No Media" is displayed, and the screen returns to the previous screen.

- Application is canceled when the [Cancel] key is pressed for 2 seconds and more while applying UV light.

### Setting

UV Scan  
Start                      -> Enter

Tap [Enter] to start.

## UV Scan2: Number of Scan

UV Scan2  
Number of UV Scan

Sets the number of times to apply UV light on the area.

- The settings here are reflected on "UV Scan1: Start" and "UV Scan3: Post Cure" only.

### Setting

Number of UV Scan  
(2-16)                      4

2 / <4> / 8 / 16

< > indicates the default setting.

## UV Scan3: Post Cure

UV Scan3  
Post Cure

When it is set to "On", the printer automatically performs post curing to apply additional UV light after printing.

### Setting

Post Cure:  
   Off



<Off> / On

< > indicates the default setting.

## Maintenance 5: Ink Discharge

Maintenance5  
Ink Discharge

Discharges the ink in the printer. This operation is performed before moving the printer.

- Before transporting the printer?  ["Transporting" P. 161](#)
- When turning off the power for up to one month?  ["If not using the printer for a long time" P. 26](#)

## Maintenance 6: Plug Life

Maintenance6  
Plug Life

Check and initialize the lifetime counter of the adapter's plug in high capacity ink pack adapter.

### Submenus

Plug Life1  
Confirm

 [Plug Life1: Plug Life Confirmation menu](#)

Plug Life2  
Initialization

 [Plug Life2: Plug Life Initialization menu](#)

### Plug Life1: Plug Life Confirmation menu

Plug Life1  
Confirm

Check each adapter's plug lifetime counter.

- The lifetime of adapter's plug is indicated by the asterisks (Maximum 5 asterisks: 100% left). As the plug deteriorates, the number of asterisks decreases one by one (20%).
- The adapter's plug should be changed when all of the asterisks have disappeared and "Change" is displayed.  
Replace the adapter's plug.  
 [Replacing Adapter's plug for high capacity ink pack adapter](#)
- After "Change" appears, "[X] Change Plug OK ->Enter" will be displayed when you are not in this menu.  
You can delete this message by tapping the [Cancel] key.

### Setting

Confirm  
Slot1: E\*\*\* F

Displays the lifetime of adapter's plug in the cartridge slot 1.  
The service life in this case is at 60%.

•  
•  
•

Confirm  
Slot6: Change

Displays the lifetime of adapter's plug in the cartridge slot 6.  
This means that the plug has already reached to the end of its life. Replace the plug.

## Plug Life2: Plug Life Initialization menu

Plug Life2  
Initialization

Initialize each adapter's plug lifetime counter.  
If you replace the adapter's plug without receiving the replacement message ([X] Change Plug OK ->Enter), use this menu to initialize the counter which you replaced.

### Setting

Initialization1  
Slot1

Initialize the adapter's plug lifetime counter in the cartridge slot 1.

•  
•  
•

Initialization6  
Slot6

Initialize the adapter's plug lifetime counter in the cartridge slot 6.



**Do not initialize the plug life for the slot number that has not been replaced. This may cause ink leakage.**

## Maintenance 7: Calibration

Maintenance7  
Calibration

Calibrate table height position information to optimize the gap between the print head and media.

["Calibrating table height" P. 55](#)

## Maintenance 8: Moving Printer

Maintenance8  
Moving Printer

Before packing printer for moving or transporting, use this menu to automatically move the table to the position to secure the table with shipping brackets.

["Changing Table Position for Packing" P. 162](#)

## Maintenance 9: Table Maintenance

Maintenance9  
Table Maintenance

Use this menu to automatically move the table to the position to perform the table maintenance.

["Table Maintenance" P. 144](#)

## Maintenance 10: Daily Maintenance

Maintenance10  
Daily Maintenance

Use this menu in following cases:

- If the nozzle missing still persists after performing head cleaning.
- If you perform printing all day without entering to sleep mode and you need to perform daily maintenance.

 ["Clean daily maintenance parts" P. 139](#)

---

### Submenus

---

Daily Maintenance  
Start —>Enter

Tap [Enter] to start maintenance.

Daily Maintenance  
End —>Enter

After the maintenance is complete, tap [Enter].

- The printer automatically performs the Short cleaning.

 **Important!**

To perform daily maintenance after using the printer for the day, see ["Daily Maintenance" P. 128](#).

# Menu4: Printer Status

## Printer Status 1: Ink

Printer Status1  
Ink

Displays the various information about ink cartridge.

### Submenus

1 2 3 4 :100/ 90/ 80/ 70  
5 6 :100/ 90

Displays the remaining amount of ink in Slot 1 to Slot 6 from 0% to 100%.

Smart/C :100%  
Max:24000ml

Display when using Smart / C.



### Note

If it is blinking at 10%, smartchip recovery is being performed on the corresponding slot.

["Smartchip recovery" P. 175](#)

## Printer Status 2: Lifetimes

### Printer Status2 Life Times

Displays the operational life time of each part.

- The lifetime of each part is indicated by the asterisks (Maximum 5 asterisks: 100% left). As the part deteriorates, the number of asterisks decreases one by one (20%).
- The part should be changed when all of the asterisks have disappeared, and "Change" is displayed. Contact your local MUTOH dealer to ask for replacing parts.
- After "Change" appears, "Life Times [Pump]" or a similar message will be displayed when you are not in this menu. You can delete this message by tapping the [Enter] key.

#### Submenus

Life Times Head: E*** F	Displays the service life for the print head.
Life Times CR Motor: Change	Displays the service life for the pump.
Life Times PF Motor: E*** F	Displays the service life for the CR motor.
Life Times Pump: E*** F	Displays the service life for the PF motor.
Life Times PG Motor: E*** F	Displays the service life for the PG motor.
Life Times C Pump: E*** F	Displays the service life for the Circulation pump.
Life Times UV Lamp: E*** F	Displays the service life for the UV lamp.
Life Times WastInkTank: E*** F	Displays the service life for the waste ink tank.

## Printer Status 3: Job Status

Printer Status3  
Job Status

Displays various information of previous print.

### Submenus

Job Status  
Status: Completed

Displays if the print is completed.

- When the print is completed: [Completed]
- When the print is canceled: [Canceled]

Job Status  
ToDoLength: XXX.Xm

Displays the total length of print data (media feeding direction).

Job Status  
Done: XXX.Xm

Displays the printed length.

Job Status  
Remain: XXX.Xm

Displays the remaining length of print data.



### Note

- The values displayed in this function are just standard values, not guarantee the accuracy.
- If the print data includes no length data, all information will be displayed as "0".
- This function is to check the information of print data with the print operation is completed. For the details on data while printing, please refer to the ["Menus you can access while printing"](#) of ["Menu3: Job Status" P. 47](#)

## Printer Status 4: Version

Printer Status4  
Version

Displays the versions of the firmware.

### Submenus

Version  
1.00

## Printer Status 5: Serial No.

Printer Status5  
Serial No.

Displays the printer's serial number.

### Submenus

Serial No.  
JM2U000000



## Printer Status 6: Total Print Area

Printer Status6  
Total Print Area

Displays the total printed area in the printer.

---

Submenus

---

Total Print Area

42949672m2

## Option 1: Rotary Unit

Option1  
Rotary Unit

Use this menu to attach the Rotary Unit (option).  
For more details of this menu, see the Rotary Unit Operation Manual.

### Note

If the printer starts switching to Rotary Mode due to wrong key operation, you can cancel it by tapping  while the following message is displayed on the operation panel.

- "Unload Media then Tap Enter"
- "Install Rotary Unit then Tap Enter"

## Menu6: Sleep Mode

### Sleep Mode1: Start

Sleep Mode1  
Start

Activate Sleep Mode.  
Make sure to follow the instructions on the operation panel to perform daily maintenance.

 ["Sleep Mode" P. 30](#)

### Sleep Mode2: Cleaning Timer

Sleep Mode2  
Cleaning Timer

Sets the timer to perform head cleaning in the sleep mode.

#### Setting values

Cleaning Timer:  
(1-24)                      24h

<Off> / 1 h / 2 h / 3 h / 4 h / 5 h / 6 h / 9 h /  
12 h / 18 h / 24 h

<> indicates the default setting.  
If you set an interval, the display will shift  
to "SleepMode 1: Start".

#### Important!

**In following cases, the printer does not perform head cleaning by the timer in sleep mode.**

- Front cover is open.
- Maintenance cover is open.
- The waste fluid tank is full.
- Ink is low (or no ink).
- The ink cartridge (or high-capacity ink pack adapter) has been removed.
- Non-genuine ink is loaded in the printer, etc.

**If one of the above conditions occurs during Head cleaning, cleaning is stopped.**

**When the printer returns to a normal state, Head cleaning is restarted.**

# Menu chart

## Setting menu 1

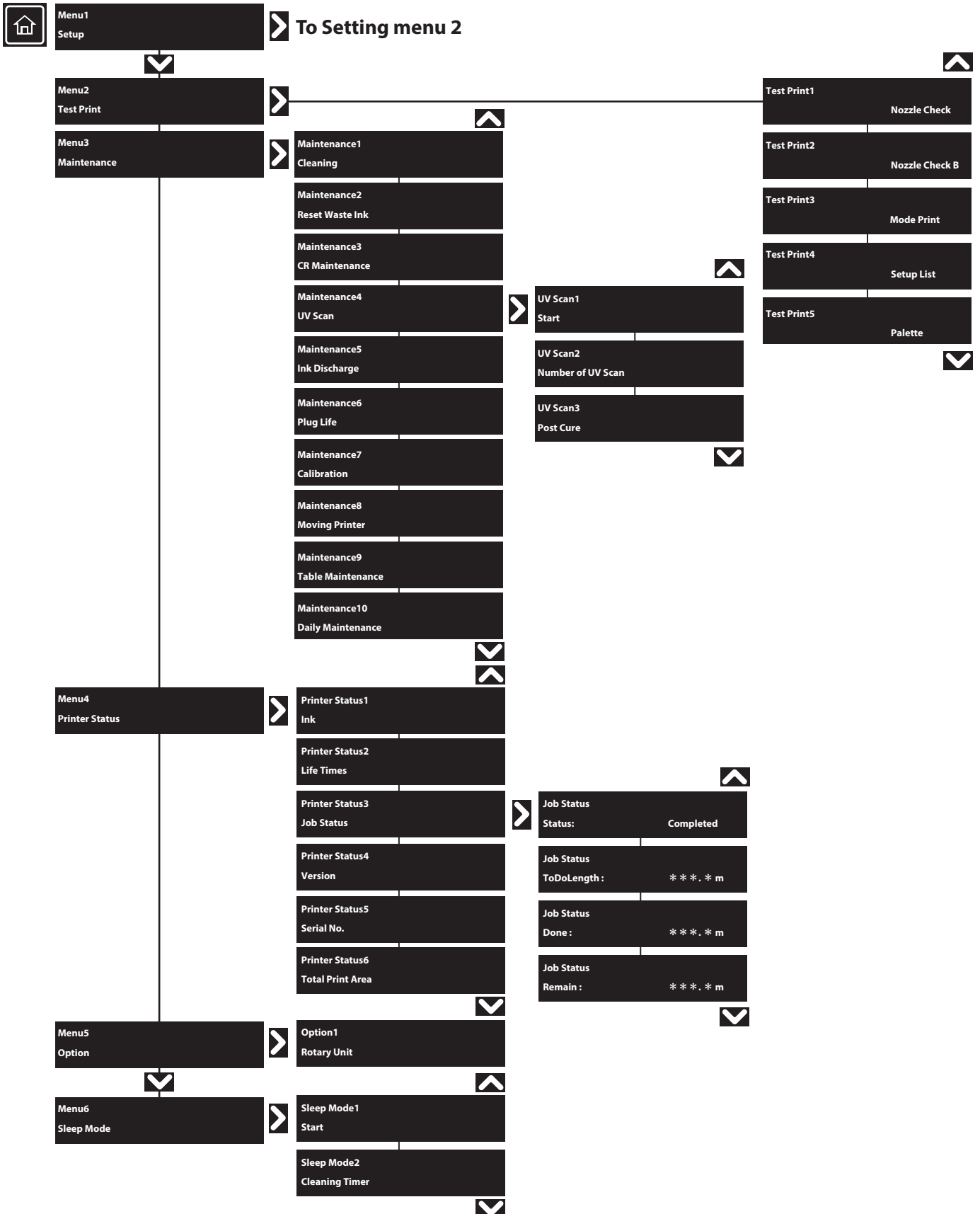

# Setting menu 2

## From Setting menu 1

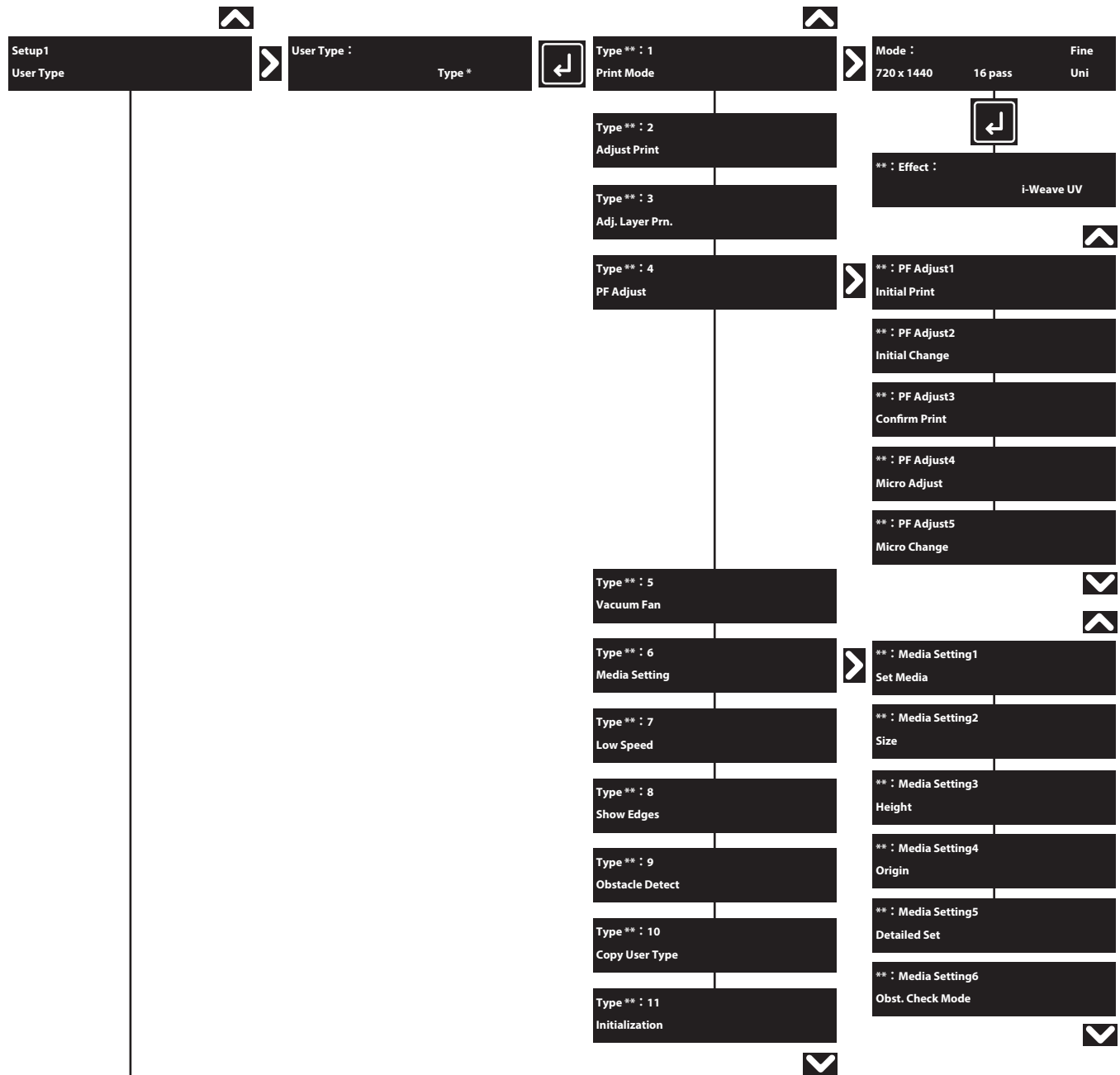

To Setting menu 3

# Setting menu 3

## From Setting menu 2

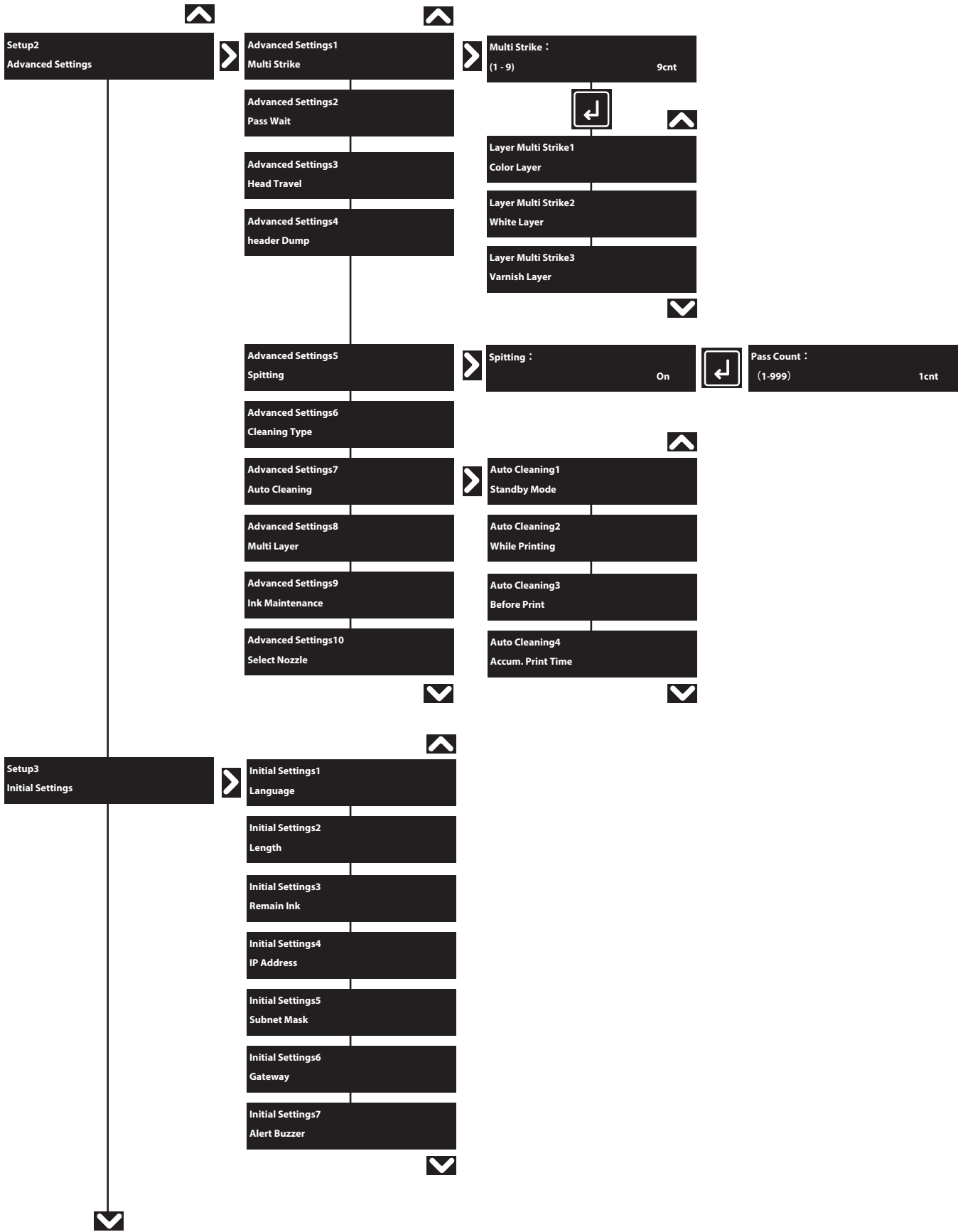

## To Setting menu 4

## Setting menu 4

### From Setting menu 3

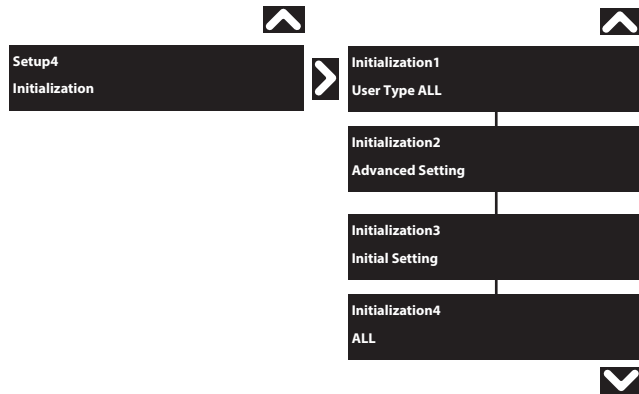

## Menu during printing

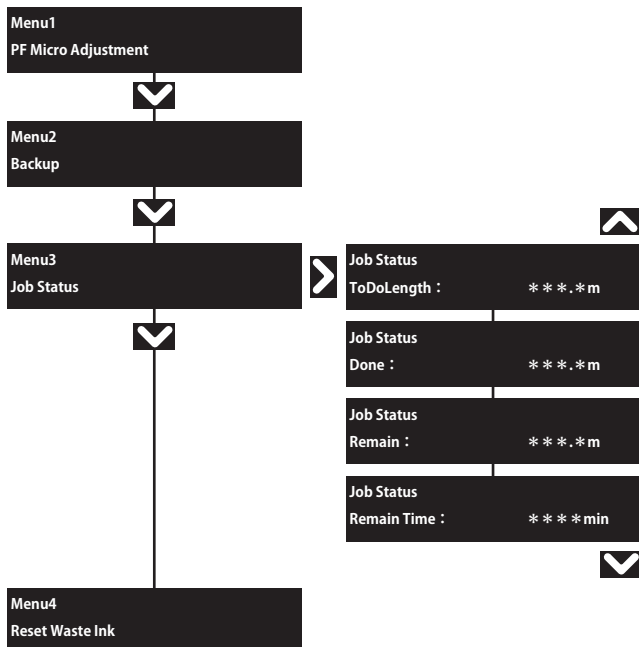





# Chapter 3 Maintenance

Maintenance .....	114
Wearing the protective equipment .....	115
How to wear the supplied gloves .....	115
Agitating ink .....	116
Agitating ink .....	116
Checking ink level and replacing ink .....	119
Checking ink level .....	119
When ink needs to be replaced soon .....	119
Replacing ink .....	120
Replacing Adapter's plug for high capacity ink pack adapter .....	123
Emptying waste ink tank .....	124
Emptying waste ink tank .....	124
Daily Maintenance .....	128
Flow of Daily Maintenance .....	128
Preparing for Daily Maintenance .....	129
Performing Daily Maintenance .....	131
Printer Maintenance .....	137
Head cleaning .....	137
Clean daily maintenance parts .....	139
Inside cleaning .....	142
Replacing consumable parts .....	147
Replacing absorption material for the flushing box .....	147
Replacing the cleaning wiper .....	151
Replacing the Emitting Window Glass on the UV-LED Lamp .....	154
Replacing UV-LED Lamp Filter .....	157
Moving and Transporting .....	160
Moving the printer .....	160
Transporting .....	161
How to perform initial ink charging after ink discharge .....	168

# Maintenance

To maintain the performance of this product, please conduct maintenance by yourself.  
The types of maintenance are shown next.

Before and after daily operation	<a href="#">"Wearing the protective equipment" P. 115</a> <a href="#">"Agitating ink" P. 116</a> <a href="#">"Nozzle check and cleaning" P. 38</a>
After daily operations	<a href="#">"Daily Maintenance" P. 128</a>
Based on your usage condition	<a href="#">"Head cleaning" P. 137</a> <a href="#">"Replacing ink" P. 120</a> <a href="#">"Replacing Adapter's plug for high capacity ink pack adapter" P. 123</a> <a href="#">"Emptying waste ink tank" P. 124</a> <a href="#">"Clean daily maintenance parts" P. 139</a> <a href="#">"Replacing absorption material for the flushing box" P. 147</a> <a href="#">"Replacing the Emitting Window Glass on the UV-LED Lamp" P. 154</a> <a href="#">"Replacing UV-LED Lamp Filter" P. 157</a>
Monthly	<a href="#">"Inside cleaning" P. 142</a>
Every six months	<a href="#">"Replacing the cleaning wiper" P. 151</a>

## Important!

**In following cases, please contact your local MUTOH dealer to request service personnel.**

- **The same system error repeatedly occurs.**
- **The message to notify the life of motor, pump, or UV lamp is displayed.**

 ["Messages and Error Messages" P. 172](#)

# Wearing the protective equipment

## ⚠ CAUTION



Skin or eye contact with UV curable ink may cause skin inflammation or allergic reaction. When using this product, wear personal protective equipment (supplied gloves or solvent-resistant gloves, goggles or protective eyewear, protective mask, protective clothing) to avoid skin contact with ink.

Especially when performing any of the following operations, be sure to wear the supplied gloves (or solvent resistant gloves) and goggles.

- "Agitating ink" P. 116
- "Replacing ink" P. 120
- "Replacing Adapter's plug for high capacity ink pack adapter" P. 123
- "Emptying waste ink tank" P. 124
- "Daily Maintenance" P. 128
- "Clean daily maintenance parts" P. 139
- "Replacing absorption material for the flushing box" P. 147
- "Replacing the cleaning wiper" P. 151
- "Replacing the Emitting Window Glass on the UV-LED Lamp" P. 154
- "Replacing UV-LED Lamp Filter" P. 157

## How to wear the supplied gloves

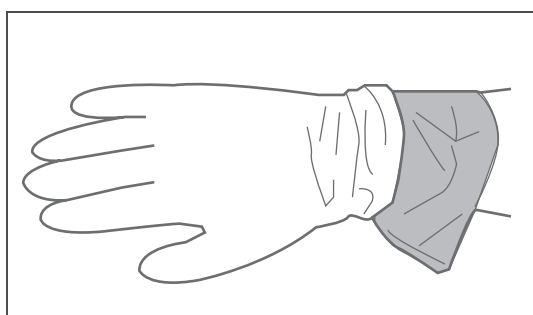

Wear the rubber gloves over the polyethylene gloves.

## ⚠ CAUTION



Do not touch uncured UV ink with bare hands.



- If glove becomes contaminated with ink, replace it with new.
- If protective clothing becomes contaminated with ink, immediately remove and wash for re-use.
- If ink gets on skin, immediately wash with soap and plenty of water for 15 minutes. Seek medical advice/attention if irritation or inflammation are present.
- If ink gets in eyes, flush eyes with plenty of water for 15 minutes and seek medical advice/attention immediately.
- If swallowed, rinse mouth immediately and do not induce to vomiting. Seek medical advice/attention.

## Agitating ink

To prevent ink settling and coagulation, you must agitate the ink in the following timing:

- Before installing new ink
- When any of the messages below appears

### 6-color configuration:

Agitate W Ink

Agitate the White (Wh) ink.

- Displays every 12 hours.

Agitate KMCY Ink

Agitate the Black (K), Magenta (M), Cyan (C), and Yellow (Y) inks.

- Displays every 72 hours when using UH21 ink.
- Displays every 48 hours when using US11 ink.

Agitate KMCYW Ink

Agitate the Black (K), Magenta (M), Cyan (C), Yellow (Y), and White (Wh) inks.

### 4-color configuration:

Agitate ALL Ink

Agitate the Black (K), Magenta (M), Cyan (C), and Yellow (Y) inks.

- Displays every 72 hours when using UH21 ink.
- Displays every 48 hours when using US11 ink.

#### Important!

- **Agitate the ink periodically. Otherwise, the ink in the ink cartridges (or ink bags) settles or coagulates and may cause poor print quality or a malfunction.**
- **The agitate ink message for CMYK inks may sometimes appear at the same timing as the one for white ink.**
- **You should agitate the ink when the message appears. Otherwise, for 12 hours after the message appears, you will repeatedly have to wait a certain time before you can print. When 12 hours have passed, the printer will not print any data. In either case, you can restore the printer to normal condition by agitating the ink.**

#### CAUTION



**Skin or eye contact with UV curable ink may cause skin inflammation or allergic reaction.**

**When using this product, wear personal protective equipment (supplied gloves or solvent-resistant gloves, goggles or protective eyewear, protective mask, protective clothing) to avoid skin contact with ink.**



## Procedure for ink cartridge

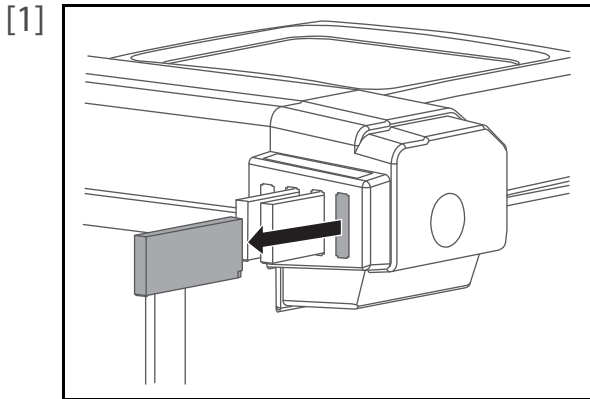

- Check the power is ON.
- Wear the supplied gloves and remove ink cartridges from Ink cartridge slots.

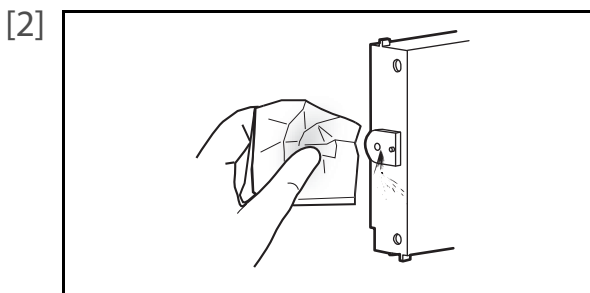

Using the paper towel provided with the printer to wipe off the ink attached to the printer plug of Ink cartridge.

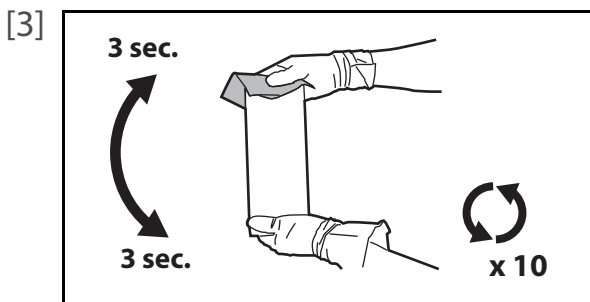

- Place the lint-free cloth over the ink plug of the cartridge, turn the plug up and maintain vertical position for three seconds.
- Rotate cartridge upside down (plug facing down) and hold for three seconds.
- Repeat it 10 times.

 **Note**

- You do not have to agitate varnish ink before use.

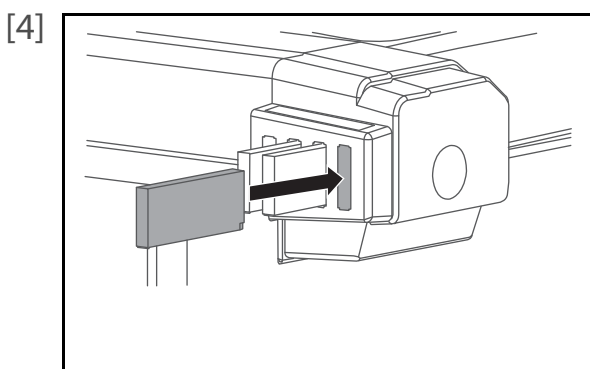

Re-insert the ink cartridges into Ink cartridge slots.

- Make sure to match the color of the ink cartridge with the color of the label above the cartridge slot.
- The arrow mark should face up.
- Insert the cartridge all the way to the end.

 **Important!**

**Make sure you insert the ink cartridges into the original slots. Even when you have the same color ink cartridges, do not switch and insert them into different slots.**

## Procedure for high-capacity ink pack adapter

 **Note**

For proper instructions of high capacity ink pack adapter, see the high capacity Ink Pack Adapter Operation Manual.

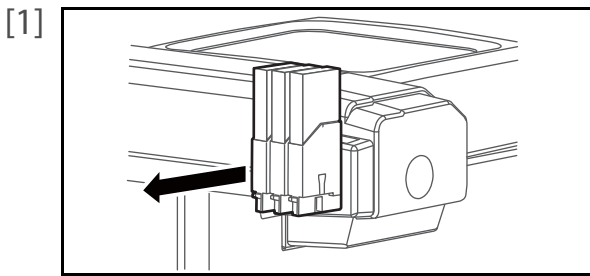

- Check that the power is ON.
- Wear the supplied gloves and remove high-capacity ink pack adapters from the cartridge slots.

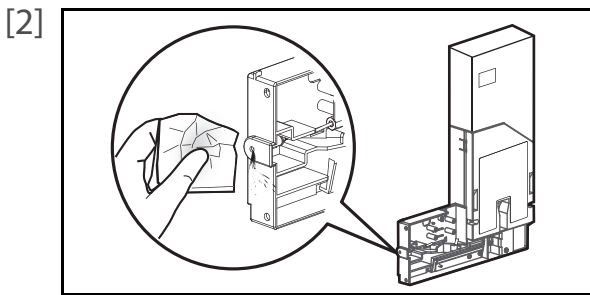

Using the paper towel provided with the printer to wipe off the ink attached to the insertion point for high capacity ink pack adapters.

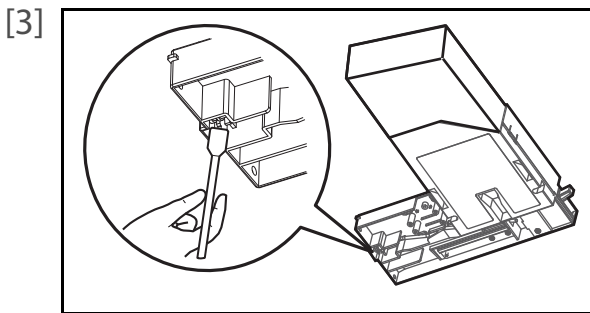

Tilt high capacity ink pack adapters, use cleaning stick provided with the printer, and absorb the ink collected around the tube connectors.

- Tilt high capacity ink pack adapter so that the caution label is facing down.
- Tilt high capacity ink pack adapter so that the insertion point is lowered a little.

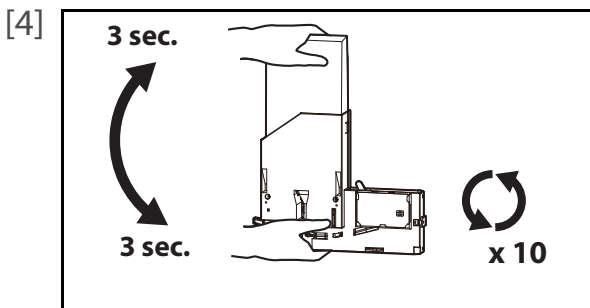

- To prevent the ink bag and the high capacity ink pack adapter from separating, hold one hand against the top of the ink bag. Rotate the plug of the ink bag vertically and hold for 3 seconds.
- Then, invert the ink bag with the adapter and hold for 3 seconds.
- Repeat that 10 times.

 **Note**

- You do not have to agitate varnish ink before use.

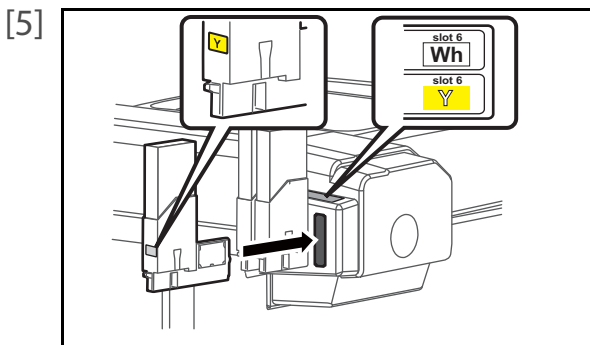

Re-insert the high capacity ink pack adapters into Ink cartridge slots.

- Make sure to match the color of the ink bag with the color of the label above the cartridge slot.
- Insert all the way to the end.

 **Important!**

**Make sure you insert the high capacity ink pack adapters into the original slots. Even when you have the same color ink packs, do not switch and insert them into different slots.**

# Checking ink level and replacing ink

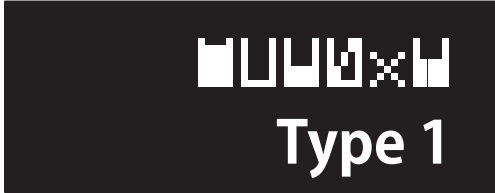

## Checking ink level



- [1]  Check the remaining ink icons.
  - To do a more detailed check, tap [Home].

**Note**

You can alternatively check the remaining ink amount via the MSM's remote panel.

 ["Launching MSM" P. 15](#)

[2] 
  - Use  to choose the menu shown left.
  - Tap .

[3]  Tap .

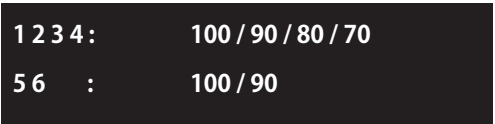
[4] 

1 2 3 4 :	100 / 90 / 80 / 70
5 6 :	100 / 90

  - Displays the remaining ink in Slots 1 to 6, as percentages of the full levels.

**Note**

If it is blinking at 10%, smartchip recovery is being performed on the corresponding slot.

 ["Smartchip recovery" P. 175](#)

## When ink needs to be replaced soon

When the ink gets low, the status LED flashes red with buzzer beeps.

### Steps

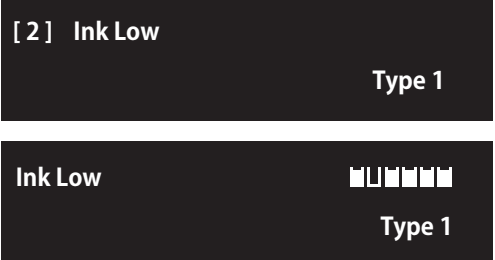
- [1]  Tap [Enter].
  - The buzzer stops.
  - The printer status and ink level warning message appear alternately every 2 seconds.
  - The ink slot indicator where the cartridge needs to be replaced flashes every 0.5 seconds.
  - In the figure to the left, the slot 2 ink is nearing replacement.

[2] Prepare an ink to replace.

**Note**

Sleep mode continues after stopping the buzzer.

## Replacing ink

When your printer is running out of ink, the status LED turns on red with beeps and printing is paused. The printer can resume printing by replacing with a new ink.

### Important!

- **Do not replace ink when the power of this product is OFF. Ink level cannot be detected correctly.**
- **In case you do not have a replacement at hand, leave the empty ink cartridge inserted in the printer. Leaving the printer with the ink removed may cause the print head to clog.**
- **If ink is moved from cold to warm place, leave it at least three hours.**

### WARNING



**Keep ink cartridges (or ink bags) away from fire or high temperature objects.**  
It may cause fire.

## Procedure for ink cartridge

[1]



Tap [Enter].

- The buzzer stops.
- In the icons shown on the left, the Slot 1 and Slot 6 cartridges need replacing.

### Note

Sleep mode continues after stopping the buzzer.

[2]

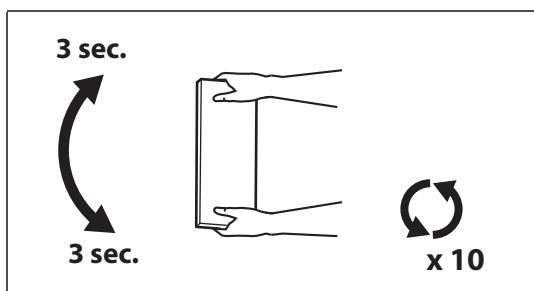

Make sure you agitate the ink cartridge after you unpack it.

- Turn the ink plug upward and wait for three seconds.
- Next, turn the ink plug downward and wait for three seconds.
- Repeat that 10 times.

### Note

- When replacing varnish ink, you do not have to agitate it.

[3]

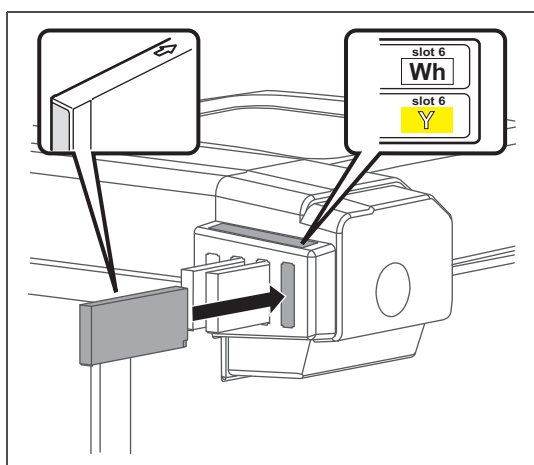

Remove the empty ink cartridge and insert the new one.

- Make sure to match the color of the ink cartridge with the color of the label above the cartridge slot.
- The arrow mark should face up.
- Insert the cartridge all the way to the end.

### Important!

**Make sure you insert the ink cartridges into the original slots. Even when you have the same color ink cartridges, do not switch and insert them into different slots.**



## Procedure for high-capacity ink pack adapter

### 1. Removing the high capacity ink pack adapter

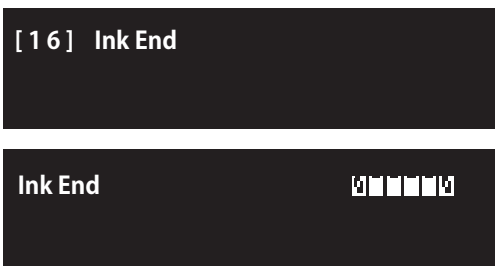
- [1]  Tap [Enter].
- The buzzer stops.
  - In the icons shown on the left, the Slot 1 and Slot 6 ink bags need replacing.

#### Note

Sleep mode continues after stopping the buzzer.

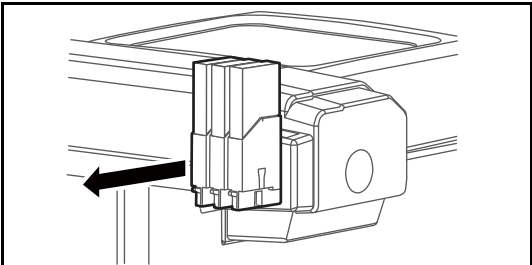
- [2]  Remove high capacity ink pack adapters from the ink cartridge slots.

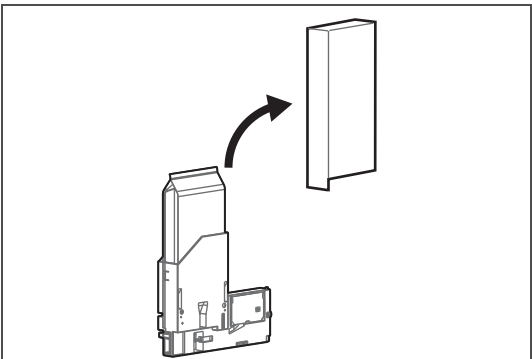
- [3]  Detach the light-shielding cover from the ink bag.

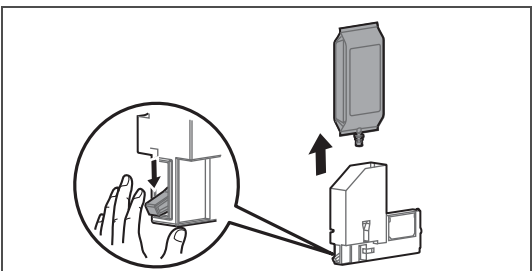
- [4]  Lower the lock lever on the high capacity ink pack adapter and detach the empty ink bag.

#### Note

Place the used ink bag in a plastic bag or the like and dispose of it in accordance with local ordinances and municipal instructions.

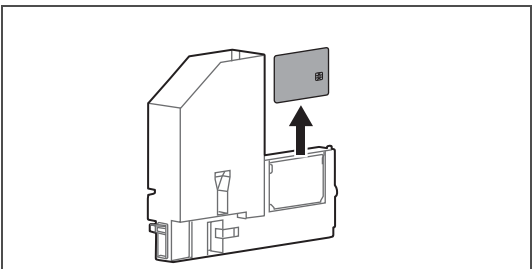
- [5]  Remove the smartchip card from the high capacity ink pack adapter.

## 2. Attaching ink bag

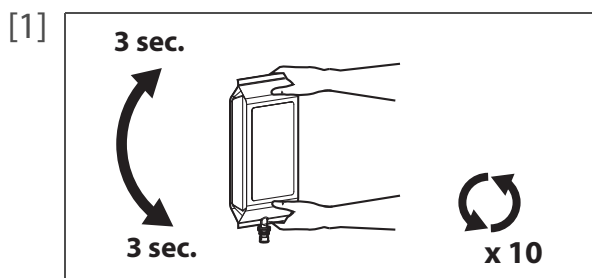

Prepare the new ink bag, and agitate it as instructed below.

- Turn the ink plug upward and wait for three seconds.
- Next, turn the ink plug downward and wait for three seconds.
- Repeat that three times.



### Note

When replacing varnish ink, you do not have to agitate it.

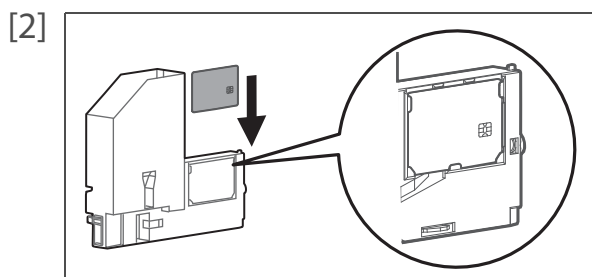

Slide the smartchip card into the tabs of the adapter.

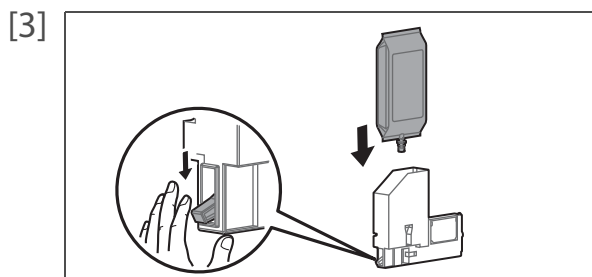

While lowering the lock lever of the high capacity ink pack adapter, insert an ink bag.

- Make sure to fully insert the ink bag into the high capacity ink pack adapter.

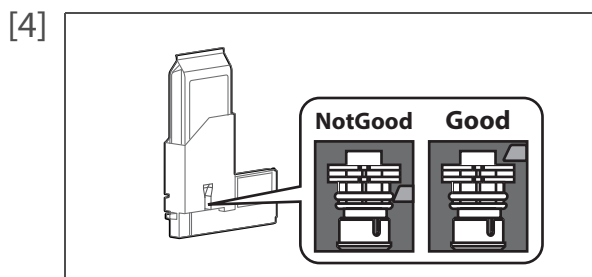

Confirm ink bag is fully seated by checking the lock mechanism is at the top of the ink delivery neck through the observation window, see proper placement in illustration left.

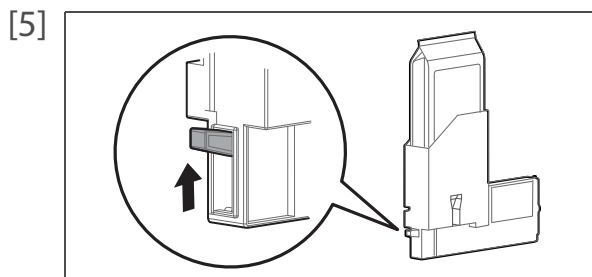

Make sure that the lock lever of the high capacity ink pack adapter is back to its original position.

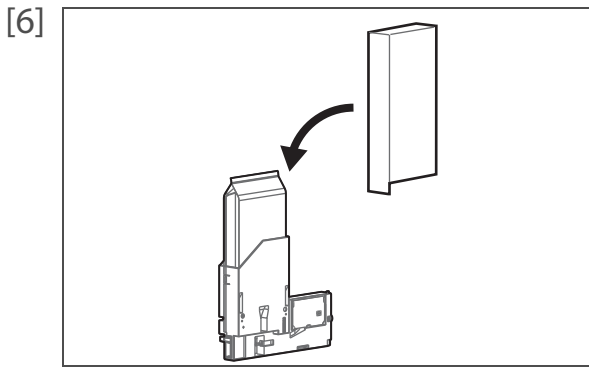

Place the light-shielding cover over the ink bag.

**Note**

Insert the light-shielding cover inside the high capacity ink pack adapter to only cover the ink bag.

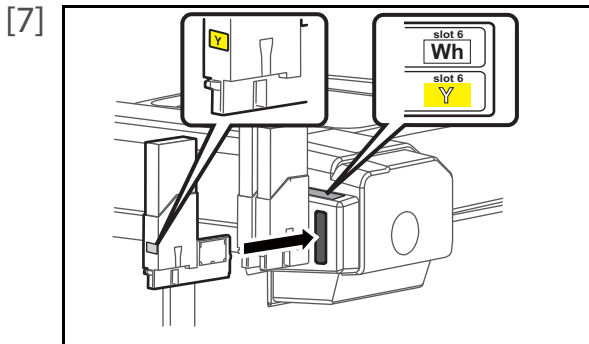

Re-insert the high capacity ink pack adapters into Ink cartridge slots.

- Make sure to match the ink color with the color of the label above the cartridge slot.
- Insert all the way to the end.

**Important!**

**Make sure you insert the high capacity ink pack adapters into the original slots. Even when you have the same color ink packs, do not switch and insert them into different slots.**

## Replacing Adapter's plug for high capacity ink pack adapter

When the plug life ends, the status LED turns on red and a message is displayed.

Follow the procedure below to replace the plug.

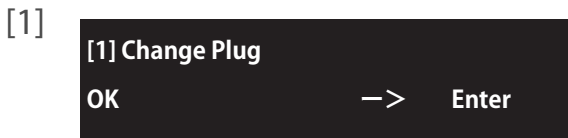

Tap [Enter].

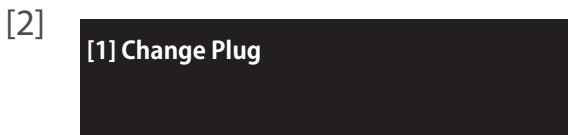

The message on the left will appear.

[3] Follow the procedure described in the operation manual for high capacity ink pack adapter.

☞ "3.3 Replacing Adapter's plug"

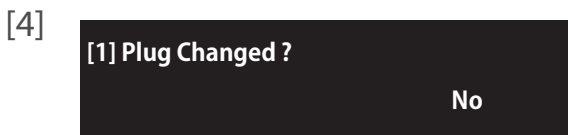

When inserting the replaced adapter, the message on the left will appear.

- Tap .

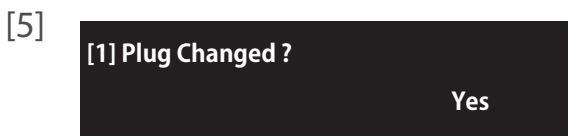

Tap [Enter].

- The adapter's plug lifetime counter will be reset.

**Important!**

- **If the adapter's plug is not replaced, do not choose "Yes".**
- **Ink leakage may occur by continuing to use such adapter's plug.**

# Emptying waste ink tank

## Emptying waste ink tank

When a certain amount of waste fluid has been collected in the waste ink tank, the status LED turns on red and beeps. Drain all waste ink in the waste ink tank into a container. After emptying the waste ink tank, reset the waste ink counter.

### Display messages

NeatFullWasteInkTank

The waste ink tank is about to become full. Mutoh recommends that you empty the waste ink tank before it is completely full.

- Printing or other operation will continue while you do this.

Full WasteInkTank

The waste ink tank has become full. Empty the waste ink tank immediately.

- Printing or other operation will stop. It will resume when you have carried out "Reset Waste Ink".

### WARNING



- Keep out of direct sunlight and store the waste ink container in a cool, dark place.
- Keep away waste fluid from fire and high temperatures.
- Do not mix waste ink with any other chemical substances, not even in small amounts. When mixed with other chemicals (e.g. oxidants), heating may occur.



- Use a HDPE container with light blocking properties to store waste liquid.
- When storing for a long time, slightly loosen the cap on the container to allow air. Do not tightly close it.

### CAUTION



Skin or eye contact with UV curable ink may cause skin inflammation or allergic reaction. When using this product, wear personal protective equipment (supplied gloves or solvent-resistant gloves, goggles or protective eyewear, protective mask, protective clothing) to avoid skin contact with ink.



### Important!

Empty the waste ink tank before moving the printer.

# 1. Drain waste ink into a container

[1] Prepare a container to collect waste ink.

## Important!

The capacity of waste ink tank is 2,000 ml. Make sure to prepare a container that has enough capacity when discharging waste ink.

## Note

If no or small amount of waste fluid is collected in the waste ink tank, you may not be able to drain fluid out of the tank.

[2] Cover the floor just under the waste ink tank using a paper that you do not use.

- [3]
- Wear the rubber gloves over the polyethylene gloves.
  - Wear personal protective equipment such as goggles, protective mask or clothing.

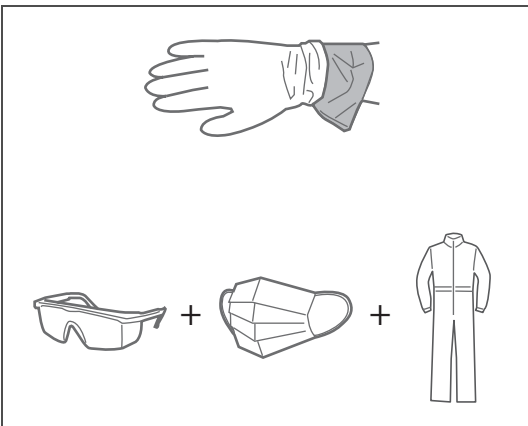

- [4]
- Open the cover of the drain tube valve clamp, then unhook the drain tube valve to take it out from the clamp.

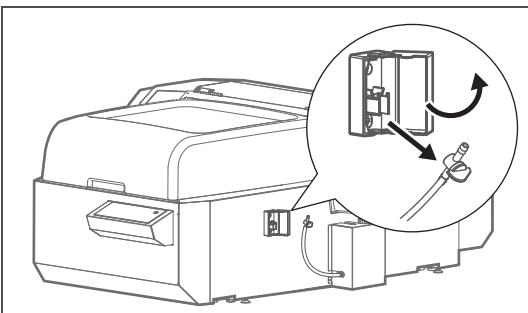

- [5]
- Put the tip of the drain tube valve in the empty container and open the drain tube valve to drain waste ink from the waste ink tank.

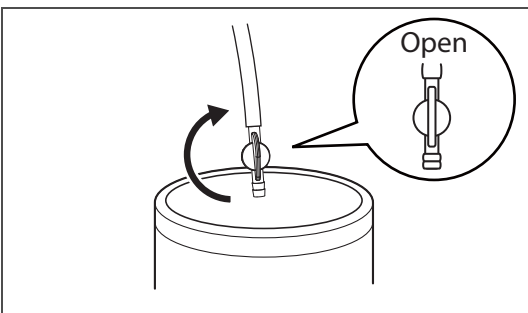

## Important!

Waste ink may splash while draining from the waste ink tank.

Make sure to put the tip of the drain tube valve in the empty container to drain waste ink.

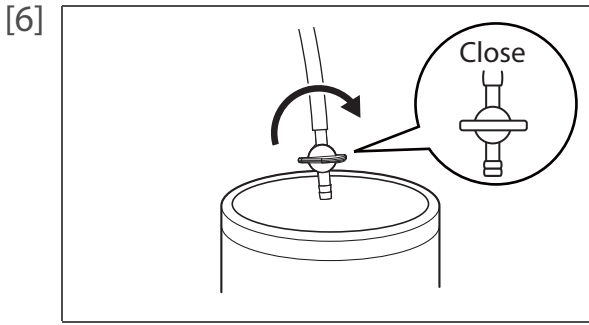

Once you finish emptying the waste ink tank, close the drain tube valve.

[7] Use a dry cloth to clean the tip of drain tube valve.

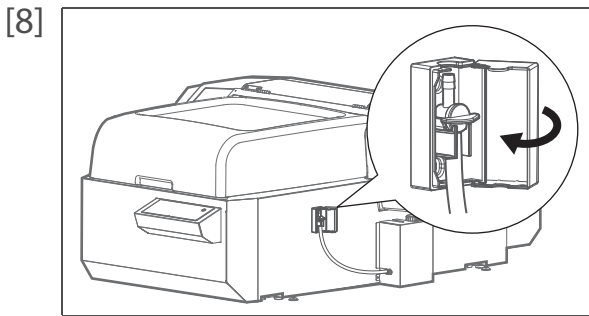

Hook the drain tube valve on the drain tube valve clamp, then close the cover.

[9] Dispose of the waste fluid as an industrial waste product.

 **WARNING**



- You are obligated to properly dispose of waste fluid from the printer in compliance with Wastes Disposal and Public Cleansing Act and local ordinances. Delegate disposal to an industrial waste disposal contractor.
- Waste fluid from this product is harmful to aquatic organisms. Avoid the waste fluid from out flowing to sewage or natural water systems.

## 2. Resetting waste ink counter

### CAUTION



**Before resetting the counter, make sure the waste ink tank is completely empty.**

If not, it can lead waste ink leaks inside or from the printer.

[1]

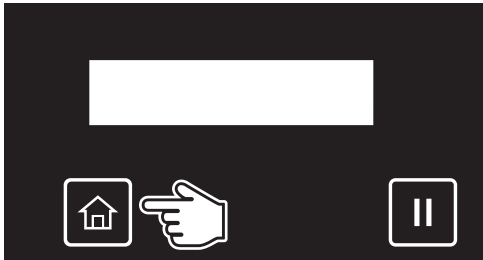

Tap [Home].

[2]



• Use  to choose the menu shown left.

• Tap .

[3]



• Use  to choose the menu shown left.

• Tap .

[4]

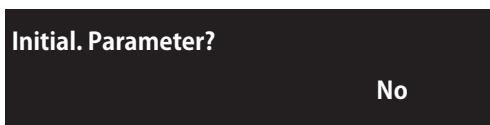

The message on the left will appear.

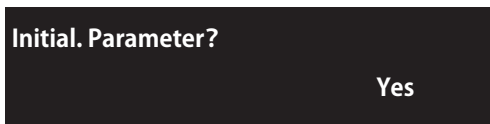

• Use  to choose the menu shown left.

• Tap [Enter].

[5]

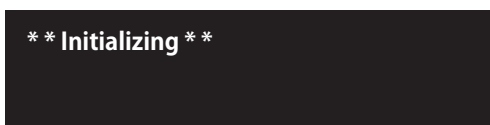

The waste ink counter is being reset.

• The waste ink tank has been emptied.

### Note

- "Reset Waste Ink" can alternatively be carried out via "Maintenance" in the printer driver's "Utility" section.
- It can also be carried out via the MSM's remote panel.
- To carry out [Reset Waste Ink] during printing, see ["Menu4: Reset Waste Ink" P. 48](#) under ["Menus you can access while printing"](#).

# Daily Maintenance

## Flow of Daily Maintenance

This printer requires daily maintenance.

Follow the steps below to perform daily maintenance after you finish your printing for the day.

- "Perform Daily Maint." is prompted on the operation panel after certain period of time from the previous daily maintenance.

Make sure to perform daily maintenance when prompted.

### Important!

**If you perform printing all day without entering to sleep mode, make sure to perform daily maintenance once a day.**

**Failure to perform daily maintenance may affect print quality or result in damage to the printer.**

**To perform daily maintenance, go to "Maintenance 10: Daily Maintenance" on the operation panel.**

 ["Maintenance 10: Daily Maintenance" P. 101](#)

 ["Clean daily maintenance parts" P. 139](#)

Prepare required items for Daily Maintenance

Leave the printer in Sleep Mode

Clean the UV Lamp

Moisten the surface of print head nozzles

Clean the print head circumference

Clean the cleaning wiper and the circumference of the cap

The printer automatically performs the Short cleaning

Daily Maintenance completed !



# Preparing for Daily Maintenance

## Required Items

[1] Prepare the following items to perform daily maintenance.



Polyethylene gloves



Rubber gloves



Protective goggles

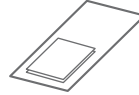

Paper towel  
or Polyester knit wiper



Dropper

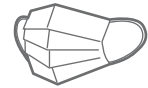

Protective mask



Dedicated maintenance  
cleaner



Plastic cup

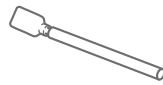

Cleaning stick



Tray



Scraper



Protective clothing

### Important!

- Use a paper towel supplied with the printer or optional polyester knit wiper. **DO NOT** use a tissue. Lints or flakes on tissue may cause damage to the print head.
- **DO NOT** use non-dedicated maintenance cleaner.
- If you want to purchase the optional maintenance cleaner, contact your local Mutoh dealer or nearest Mutoh sales office.

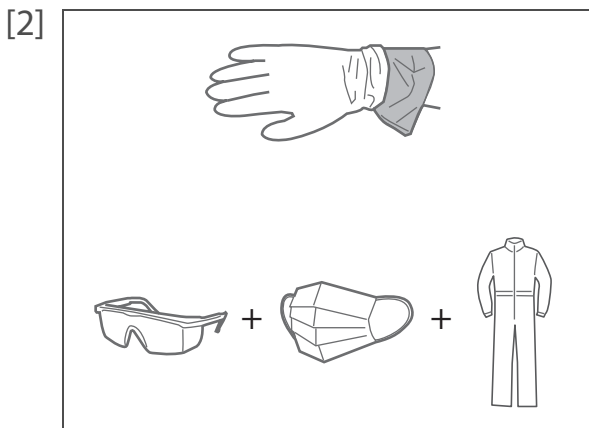

- Wear the rubber gloves over the polyethylene gloves.
- Wear personal protective equipment such as goggles, protective mask or clothing.

### CAUTION



**Skin or eye contact with UV curable ink may cause skin inflammation or allergic reaction. When using this product, wear personal protective equipment (supplied gloves or solvent-resistant gloves, goggles or protective eyewear, protective mask, protective clothing) to avoid skin contact with ink.**



## Entering to sleep mode

---

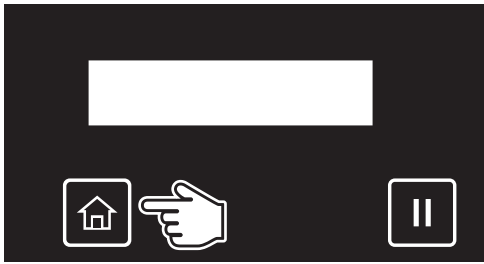

[1]



Tap [Home].

[2]



- Use  to choose the menu shown left.
- Tap .

[3]



Tap .

[4]



Tap [Enter].

[5]

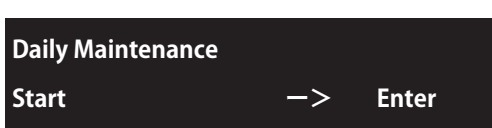

Tap [Enter].

[6]



The message on the left will appear.

- Remove the media and the jig on the table, and then tap [Enter].



- The table, carriage and cleaning wiper move to gain access to daily maintenance.

[7]

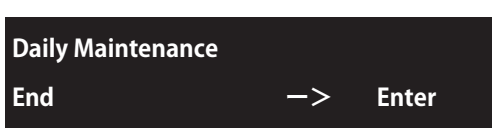

The message on the left will appear.

- You can start maintenance.



**Make sure to complete this maintenance within 5 minutes while the printer is in Daily maintenance state.**

# Performing Daily Maintenance

## 1. Cleaning of UV Lamp

### CAUTION



After printing, the UV-LED lamp may get hot.  
Leave it for 30 minutes to cool down and then start maintenance.

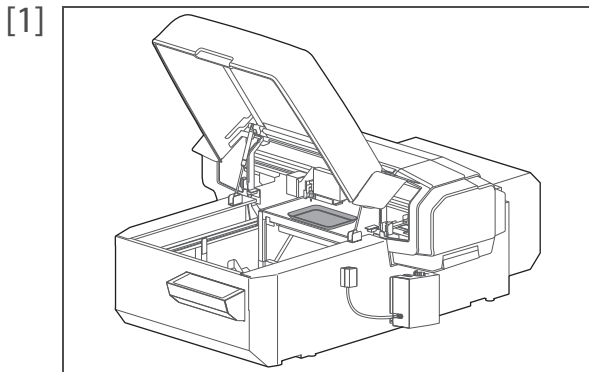

Open the front cover gently, and then place the tray on the table.

 Important!

**Do not place any object inside the printer.**

- [2] Look in the stainless tray to check for ink or dust on the UV-LED lamp.  
If no ink or dust is found on the UV lamp, skip this step and move on to "[Moistening the surface of print head nozzles](#)" [P. 133](#).

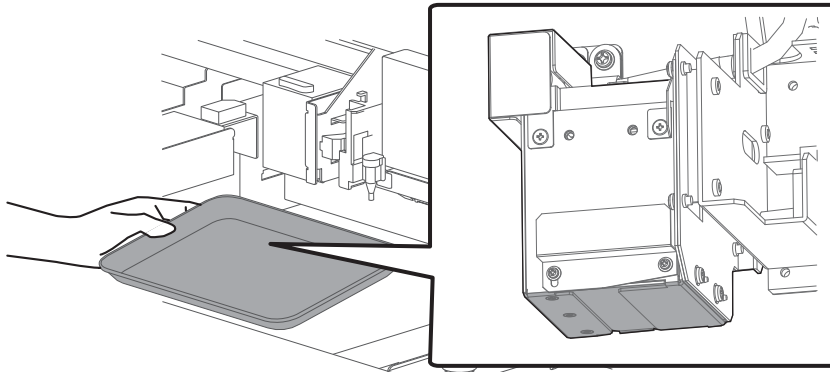

- [3] Use a paper towel to clean dust or ink off the underside of the UV-LED lamp.

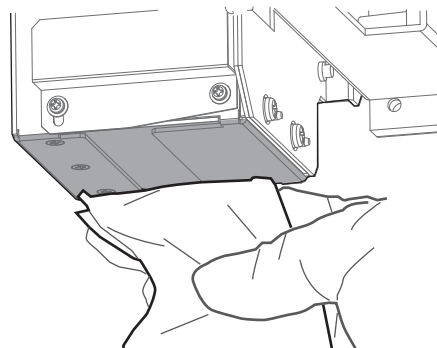

[4] If the ink cannot be removed completely, remove the emitting window glass from the lamp and use the supplied scraper to clean it off.

- Slide up the left side of the exhaust fan cover. The right side screw serves as a fulcrum.
- Slide the glass on the bottom of the lamp towards the front to remove it.
- Press the scraper on the ink deposits with a slight angle and scrape it off.
- Use the paper towel to clean the ink scraped from the glass.
- Put the glass back on the lamp.
- Firmly slide it into the end and then put the exhaust fan cover back in place.

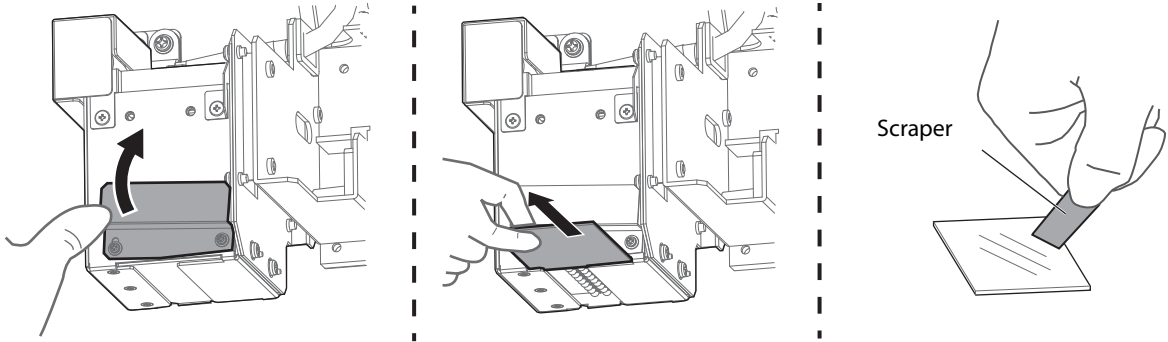

 **Important!**

- **Make sure to use the scraper supplied with the printer.**
- **Do not press the edge of the scraper too hard. This will cause damage to the glass.**
- **Make sure that a new glass is attached to the lamp and the exhaust fan cover is put back in place. Using your printer without them will cause damage to the lamp.**

[5] Next moisten the surface of print head nozzles.

## 2. Moistening the surface of print head nozzles

### Important!

During cleaning, please note the followings:

- Always follow this steps to perform daily maintenance.
- When moistening the surface of nozzles, do not use the cleaning stick already used to clean the print head circumference, cleaning wiper or cap circumference. Doing so may result in damage to the print head.
- Always use a new cleaning stick and dampen it with dedicated maintenance cleaner. DO NOT use non-dedicated maintenance cleaner. It may cause nozzle clogging.
- Do not touch the tip of a cleaning stick with fingers. If sebum is adhered, it can cause damage to the print head.
- Do not reuse a cleaning stick. Dusts can adhere causing damage to the print head.

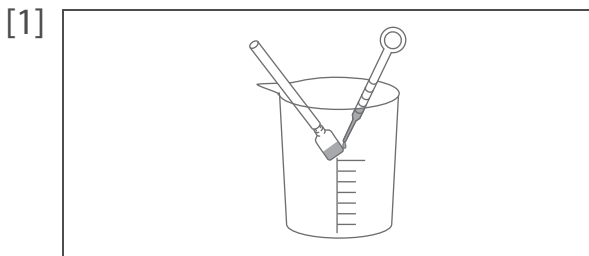

- Put a cleaning stick in the plastic cup.
- Use the dropper to dampen the swab of cleaning stick with dedicated maintenance cleaner. (Amount used: 0.5 ml)

- [2] Look in the stainless tray to check the bottom of the carriage. Using the cleaning stick dampened with the maintenance cleaner, moisten the surface of the print head nozzles.
- Lightly touch with the cleaning stick to moisten the nozzle surface.
  - Repeat it a couple of times to moisten the entire nozzle surface.

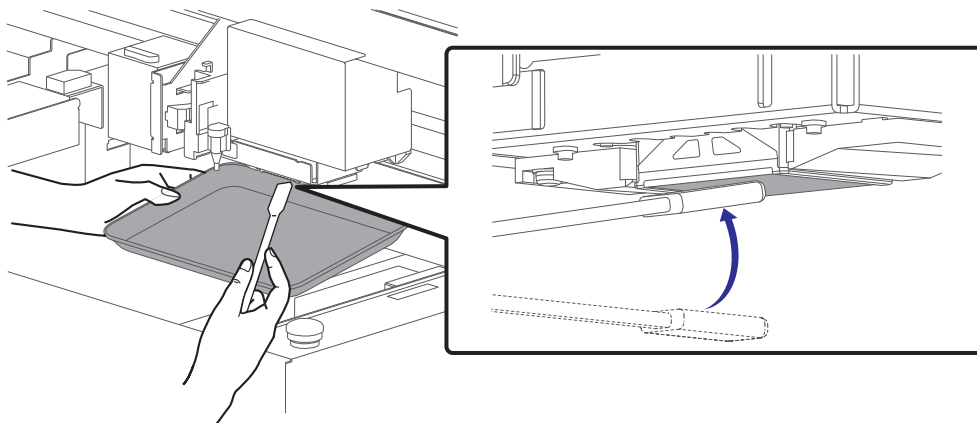

### Important!

- DO NOT rub into the nozzle surface. It can cause damage to the print head.
- If the entire nozzle surface has been moistened, you can stop it.

- [3] Next clean the print head circumference.

### 3. Cleaning of print head circumference

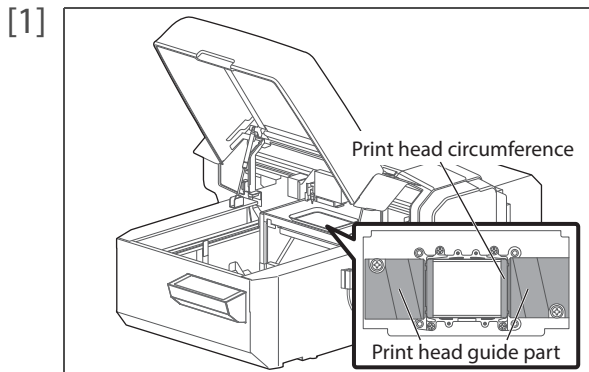

Look in the tray to check the bottom of the carriage. Check if dusts and ink deposit are adhered.

- Print head circumference (silver metal part)
- Print head guide part (black plastic part)

**Important!**

**If maintenance cleaner is splashed onto the printer, use a paper towel to wipe it off.**

[2] Use the cleaning stick to remove the ink and dust on the circumference of the bottom of the carriage.

 Cleaning required

 **DO NOT touch the surface of a print head (the yellow portions in the illustration below)**

Print head circumference (silver metal part)

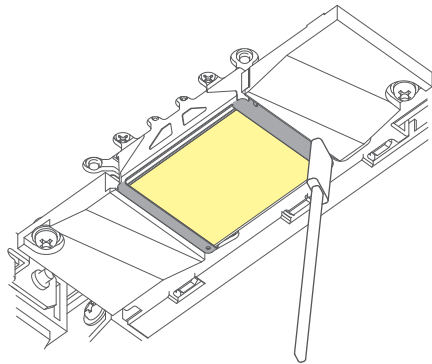

Print head guide part (black plastic part)

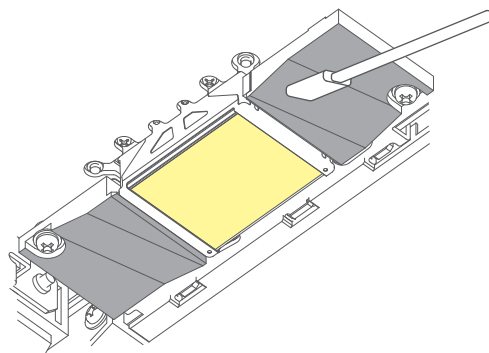

[3] Remove the tray from the table, and then close the front cover gently.

[4] Next clean the cleaning wiper and the cap circumference.

## 4. Cleaning of cleaning wiper and the circumference of the cap

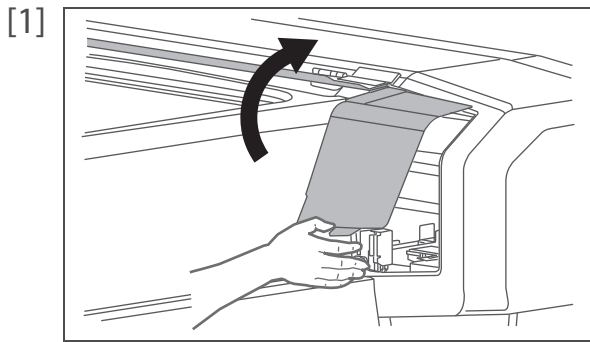

Hold the tab on the maintenance cover as shown on the left to gently open the cover.

- Fully open the maintenance cover.

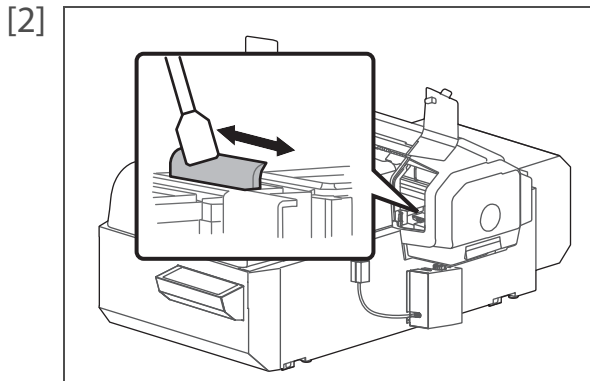

Wipe the cleaning wiper with a cleaning stick.

- Wipe the left side surface of cleaning wiper going back and forth.

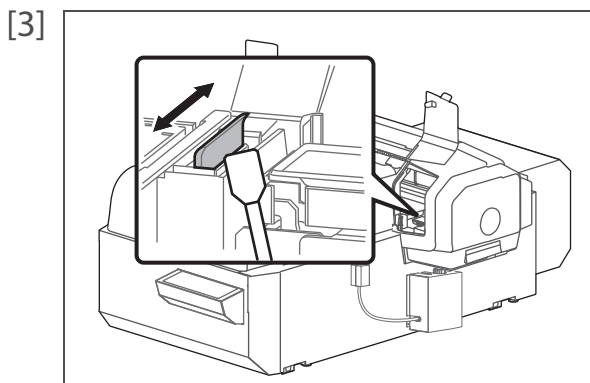

Wipe the right side surface of cleaning wiper going back and forth.

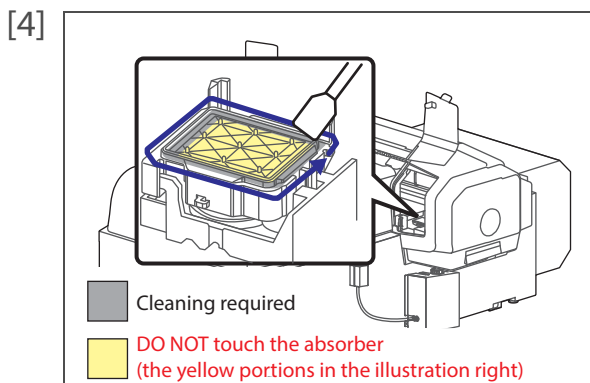

Use the cleaning stick to remove the ink and dust on the circumference of the cap.

[5] Close the maintenance cover gently.

[6] Next finish the daily maintenance.

## 5. Finishing daily maintenance

---

[1] Tap [Enter].

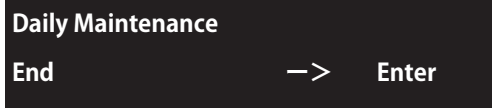

[2] The printer automatically performs the Short cleaning.

[3] When the Short cleaning is complete, the printer automatically enters to sleep mode.

- [4]
- Dispose of the used cleaning stick.
  - Use a paper towel to wipe the maintenance cleaner off the dropper.
  - Dispose of the maintenance cleaner in the plastic cup and dry the cup well using the paper towel.
  - Use a paper towel to clean the tray.

### Important!

- **Do not reuse a cleaning stick.**  
**Dusts can adhere causing damage to the print head.**
- **Check that the lid of the maintenance cleaner is shut properly and store it.**

[5] Now the daily maintenance is complete.

### Note





Used cleaning stick should be put in a plastic bag, etc, and dispose of it in compliance with local ordinance and instructions of local authorities.



## Head cleaning

When nozzle clogging is found in nozzle check, conduct head cleaning. Head cleaning consumes ink. There are several cleaning modes in this product. Please select an appropriate mode based on your usage condition.

---

Short cleaning	Consumes less ink than Normal cleaning.
Normal cleaning	Perform Normal cleaning if nozzle clogging is found on the nozzle check print.
Long cleaning	Perform Long cleaning if nozzle clogging still persists after performing Normal cleaning. It consumes more ink than Normal cleaning.
Little Charge	Provide higher cleaning effect than Long cleaning, but it also consumes more ink. *This mode cannot be selected via the  . Select it from the Cleaning submenu in the Panel Setting Menus.  <a href="#">"Maintenance 1: Cleaning" P. 96</a>
Initial Charge	Provide higher cleaning effect than Little Charge, but it also consumes more ink. *This mode cannot be selected via the  . Select it from the Cleaning submenu in the Panel Setting Menus.  <a href="#">"Maintenance 1: Cleaning" P. 96</a>

---

### Important!



**Comply strictly with the following when you performing "Little Charge" or "Initial Charge". If charging is interrupted, ink will be lost when charging is resumed.**



- **Do not open the Front cover or the Maintenance cover.**
- **Do not use ink cartridges (or ink bags) that have little ink remaining.**

## Steps for head cleaning

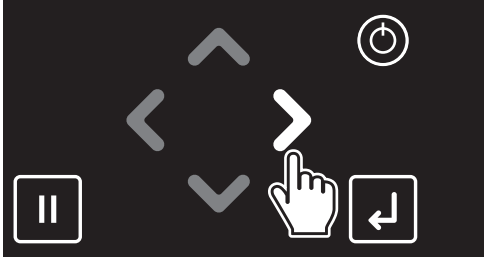
---

[1]  Check that the message on the left is displayed.

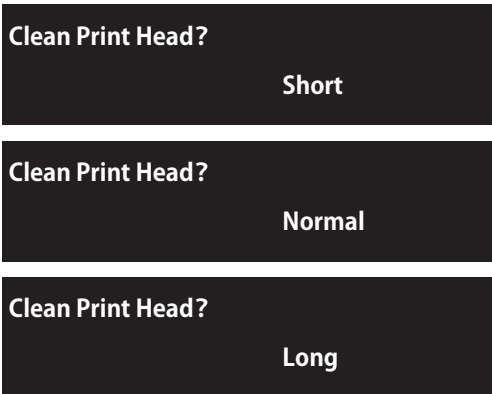
[2]  Tap .

[3]  Use  or  to choose the cleaning mode.  
Tap [Enter].

- The printer will start cleaning.

[4] Run a nozzle check print.

- If the problem persists, repeat normal cleaning until all nozzles are clear.

 ["Steps for head cleaning" P. 138](#)

### Note

- When nozzle clogging remains even after repeating "Normal cleaning" several times, conduct "Long cleaning".
- When nozzle clogging remains even after repeating "Long cleaning" several times, conduct ["Clean daily maintenance parts" P. 139](#).
- If it does not help to recover the nozzle, carry out "LittleCharge" via the ["Maintenance 1: Cleaning" P. 96](#) in the Panel Setting Menus.

## Clean daily maintenance parts

In following cases, clean the daily maintenance parts.

- If faint print or dot missing still persists even after head cleaning has been performed.
- If you perform printing all day without entering to sleep mode and you need to perform daily maintenance.

### Preparation:

See "[Preparing for Daily Maintenance](#)" P. 129 to prepare items required for the maintenance.



**If you want to continuously use the printer after this maintenance, follow the steps below.**  
**If you will not use the printer after this maintenance, enter to sleep mode and then perform maintenance.**

"[Daily Maintenance](#)" P. 128

### 1. Putting the printer into the Daily maintenance mode

---

[1] Check that the media and jig are removed from the printer.

[2]  Tap [Home].

[3] 

- Use to choose the menu shown left.
- Tap .

[4] 

- Use to choose the menu shown left.
- Tap .

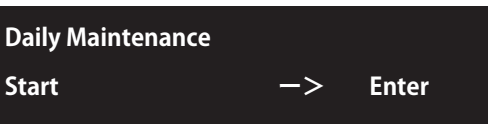
[5]  Tap [Enter].

[6]  The message on the left will appear. 

- Remove the media and the jig on the table, and then tap [Enter].

 Please Wait

- The table, carriage and cleaning wiper move to gain access to maintenance.

[7]



Daily Maintenance  
End                      —>                      Enter

The message on the left will appear.





- You can start maintenance.

## 2. Cleaning daily maintenance parts

---

The maintenance procedure and parts to be cleaned are the same as ["Daily Maintenance" P. 128](#).

Follow the steps described in ["Performing Daily Maintenance" P. 131](#) to clean each part.

-  ["Cleaning of UV Lamp" P. 131](#)
-  ["Moistening the surface of print head nozzles" P. 133](#)
-  ["Cleaning of print head circumference" P. 134](#)
-  ["Cleaning of cleaning wiper and the circumference of the cap" P. 135](#)



**Make sure to complete this maintenance within 5 minutes while the printer is in Daily maintenance state.**

### 3. Finishing maintenance

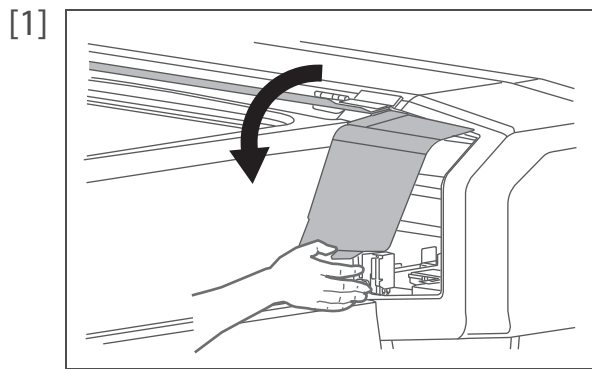

Hold the tab on the maintenance cover as shown on the left to gently open the cover.

#### CAUTION



**When closing the maintenance cover, hold the tab on the maintenance cover to gently close it.**

Do not place your fingers on the edges of the printer's opening portion, or on any parts around those edges. Your fingers could get caught and be injured.

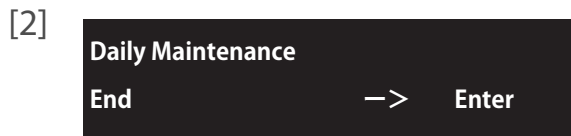

Tap [Enter].

[3] The printer automatically performs the Short cleaning.

- [4]
- Dispose of the used cleaning stick.
  - Use a paper towel to wipe the maintenance cleaner off the dropper.
  - Dispose of the maintenance cleaner in the plastic cup and dry the cup well using the paper towel.
  - Use a paper towel to clean the tray.

#### Important!

- **Do not reuse a cleaning stick.**  
**Dusts can adhere causing damage to the print head.**
- **Check that the lid of the maintenance cleaner is shut properly and store it.**

[5] Now the maintenance is complete.

## Inside cleaning

### Cleaning period:

- Monthly

### ⚠ CAUTION



- **When cleaning table, do not apply too much pressure on the table.**  
It can affect print quality.

### 1. Cleaning on the table

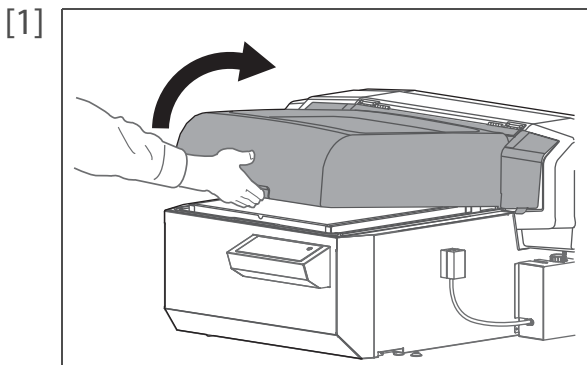

Hold the handle on the front cover to gently open it.

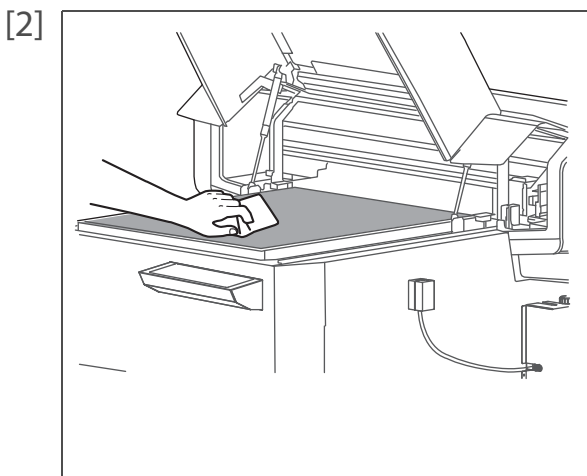

Clean away dirt from the table using a cloth soaked in water and thoroughly wrung out.

#### 🔊 Important!

- **Do not blow off dusts inside the product with a gas duster.**  
Dust can attach to moving parts, causing abnormal sound or malfunctions.
- **Do not rub the hardened ink on the table with the included scraper.**  
The table may be damaged.

#### 📝 Note

If ink on the table cannot be removed, use your personal resin squeegee or scraper to remove it. Be sure not to damage the table.

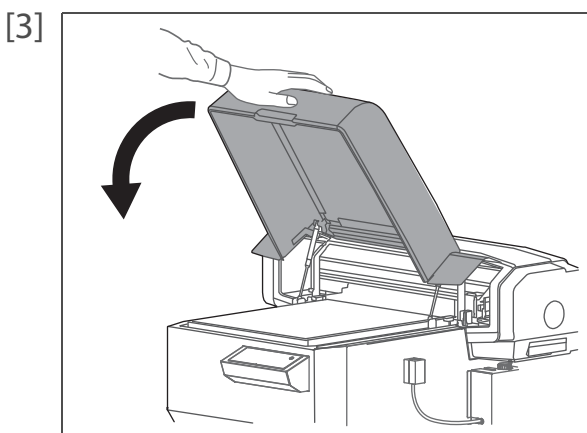

Close the front cover slowly, holding it by the place shown in the picture.

## 2. Cleaning on the table rail

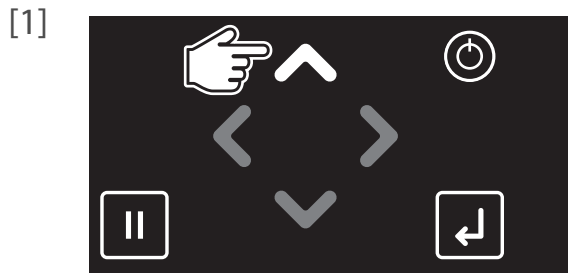

Check that the cover is closed and then tap .

- The table moves to the rear side of the printer.

[2] Hold the handle on the front cover to gently open it.

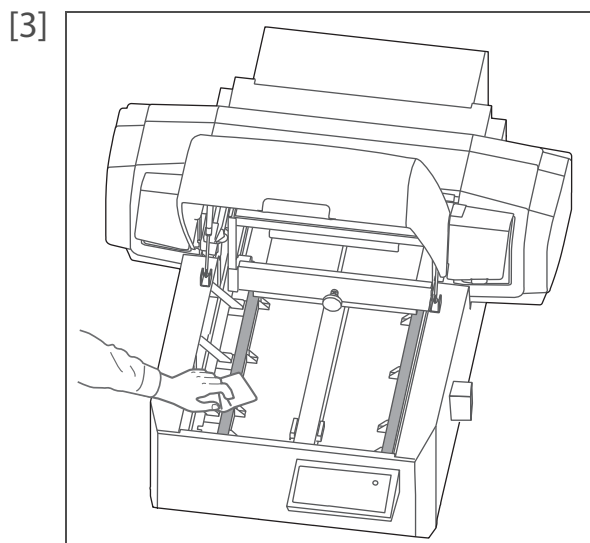

If found any dirt or dust on the table rail, use a soft cloth, dampened with water and then wrung water out of the cloth, to remove it from the rail.

 **Important!**

- **If any dirt or dust remains on the table rail, it may reduce print quality.**
- **Do not blow off dusts inside the printer with a gas duster. Dust can attach to moving parts, causing abnormal sound or malfunctions.**

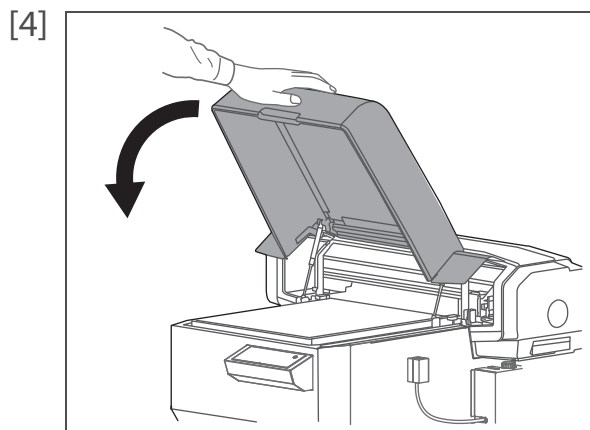

Close the front cover slowly, holding it by the place shown in the picture.

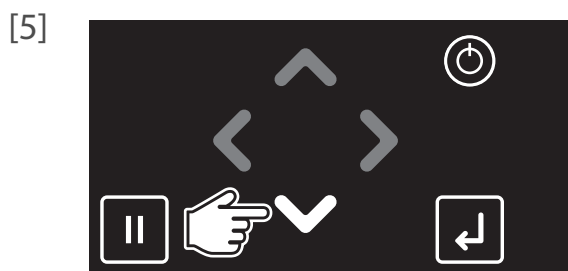

Check that the cover is closed and then tap .

- The table moves to the front side of the printer.
- That ends the procedure.

### 3. Table Maintenance

---

#### Preparation:

- Paper Towel (Lint-free cloth) or Polyester knit wiper (optional)
- Lubricating grease
- Cleaning stick



During cleaning, please note the followings.

- **DO NOT** apply lubricating grease on area other than specified.
- Always use the paper towel (lint-free cloth) supplied with the printer or optional polyester knit wiper. **DO NOT** use tissue paper.
- When using this product, do not place any object in the table height detection area. This will cause false detection and the printer will not be able to print correctly.  
Also, the area in front of the guide groove on the front side of the table is outside the sensing area of the obstacle detection sensor. Do not place any object thicker than the media being loaded in this area. This will cause head strike, leading to damage to the print head.

For details, see the following section:

["Printing area" P. 32](#)

#### Before greasing

---

[1] If any media or jig is loaded on the table, open the front cover and remove it.

[2]  Check that the front cover is closed, and tap [Home].

[3] 

- Use to choose the menu shown left.
- Tap .

[4] 

- Use to choose the menu shown left.
- Tap .

[5]  Tap [Enter].



- The table moves to the front side of the printer.



[6] **Unload Media**  
then Tap Enter

The message on the left will appear.  
• Remove the media and the jig on the table, and then tap [Enter].

**Please Wait**

• The table moves to the position to perform the screw shaft maintenance.

[7] **Table Maintenance**  
End                      ->      Enter

The message on the left will appear.  
• You can start table maintenance.

## Steps for greasing

---

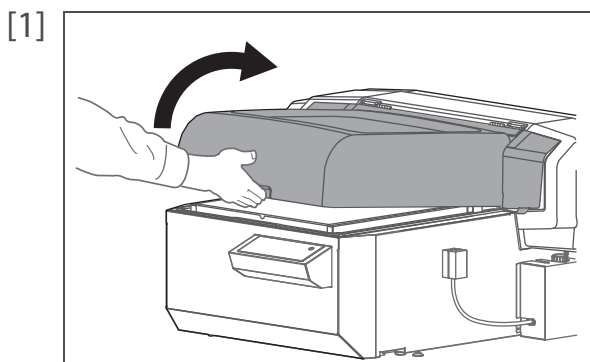

Hold the handle on the front cover to gently open it.

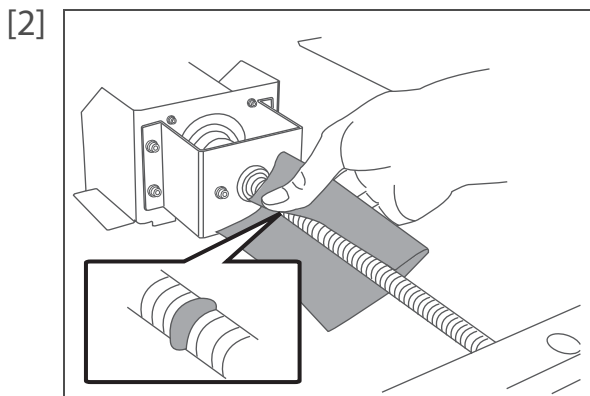

Use the paper towel supplied with the printer to lightly wipe off grease built up on the screw shaft as shown in figure left.

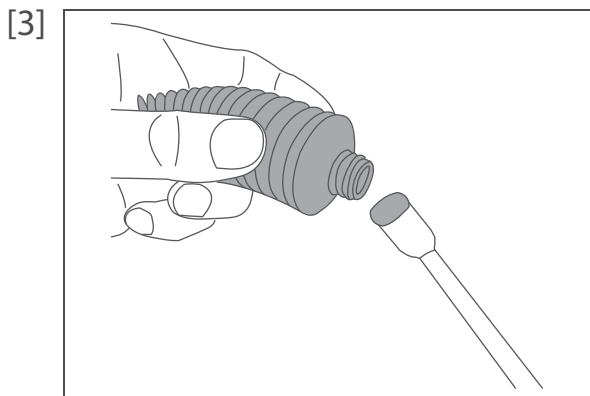

Apply approximately 5 mm of lubricating grease on the cleaning stick.

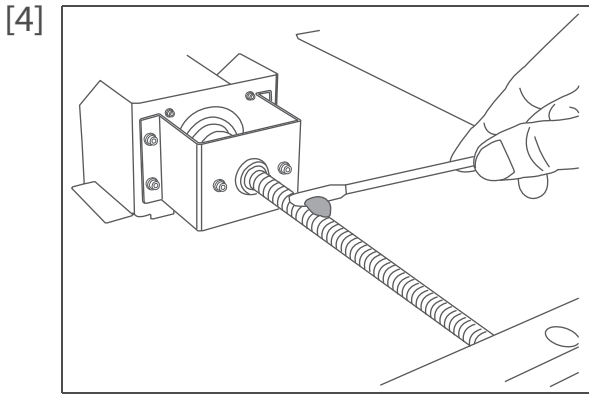

Apply the grease on the screw shaft.

- Apply it on the area where the grease was built up in Step 2.

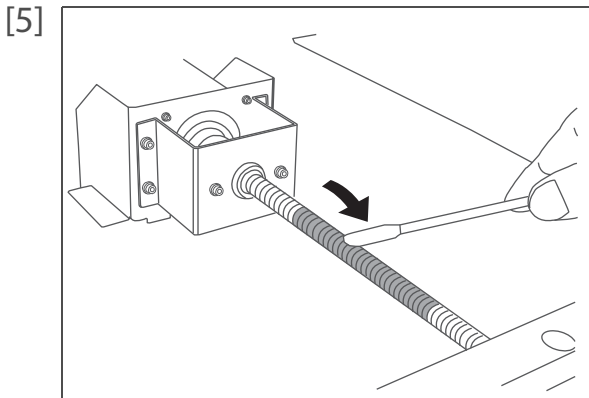

Apply it evenly on the screw shaft.

- Using the cleaning stick, apply it towards the front to evenly grease on the screw shaft.

### After greasing

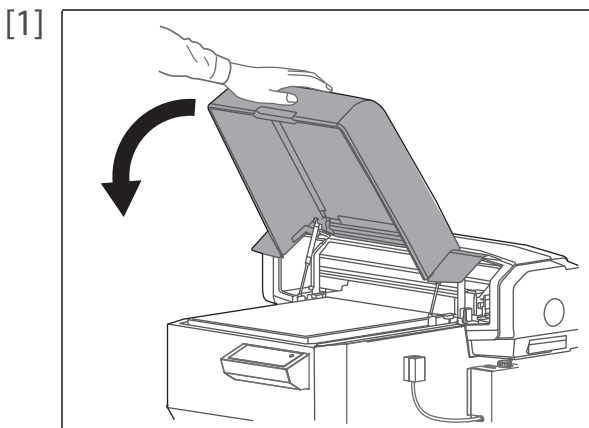

Close the front cover slowly, holding it by the place shown in the picture.

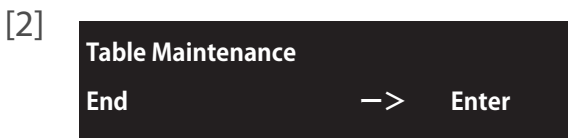

Tap [Enter].

- The table moves up and down to smooth out the grease on the shaft.
- The table moves to the original position.

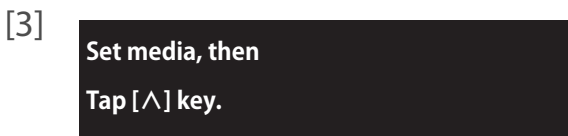

The message on the left will appear.

- That ends the procedure.

# Replacing consumable parts

## Replacing absorption material for the flushing box

The flushing box is a part that keeps receiving ink discharged from the print head. Please replace the absorption material for the flushing box periodically. If used without replacing, it can cause damage to the print head.

### Replacing period:

- When ink clumps have accumulated on the flushing-box sponges beyond the flushing-box frame. (since it differs depending on usage frequency, please check periodically)

### CAUTION



**Skin or eye contact with UV curable ink may cause skin inflammation or allergic reaction.**  
**When using this product, wear personal protective equipment (supplied gloves or solvent-resistant gloves, goggles or protective eyewear, protective mask, protective clothing) to avoid skin contact with ink.**



**Do not open or close the cover while you are off balance.**  
You may pinch your finger or get injured.

## 1. Checking steps

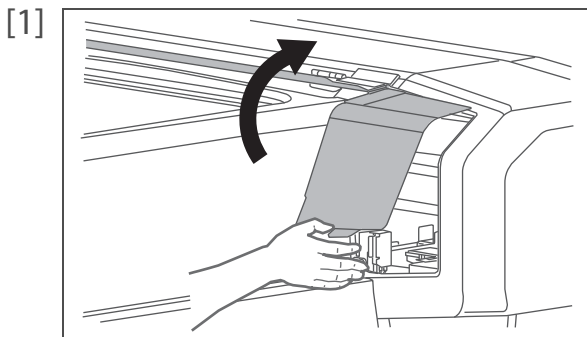

Hold the tab on the maintenance cover as shown on the left to gently open the cover.

- Fully open the maintenance cover.

### CAUTION



**Always fully open the maintenance cover.**  
If you leave it half-open, the maintenance cover can suddenly close.

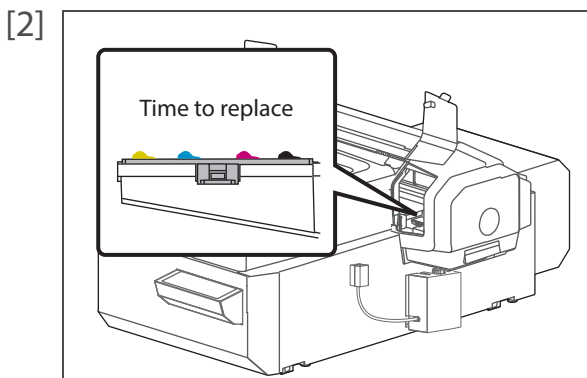

- Check the absorption material for the flushing box.
- If the ink deposit is visible on the flushing box, replace the absorption material.

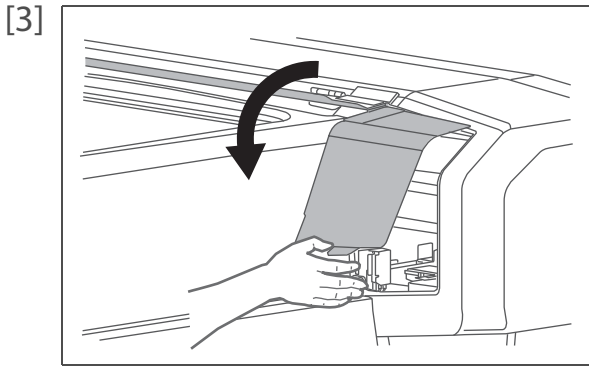

Hold the tab on the maintenance cover as shown on the left to gently close the cover.

**CAUTION**



**When closing the maintenance cover, hold the tab on the maintenance cover to gently close it.**

Do not place your fingers on the edges of the printer's opening portion, or on any parts around those edges. Your fingers could get caught and be injured.

## 2. Replacing steps

[1] Check that the media and jig are removed from the printer.



Tap [Home].



- Use to choose the menu shown left.
- Tap .

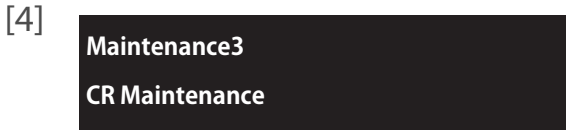

- Use to choose the menu shown left.
- Tap .

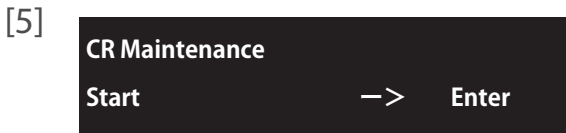

Tap [Enter].

- The carriage will move to the left side of the printer.
- The cleaning wiper will move upward.

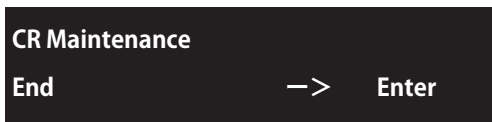

The message on the left will appear.

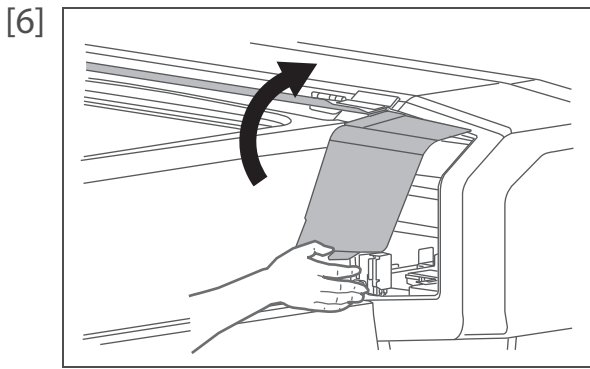

Hold the handle on the front cover to gently open it.

- Fully open the maintenance cover.

**CAUTION**



**Always fully open the maintenance cover.**

If you leave it half-open, the maintenance cover can suddenly close.

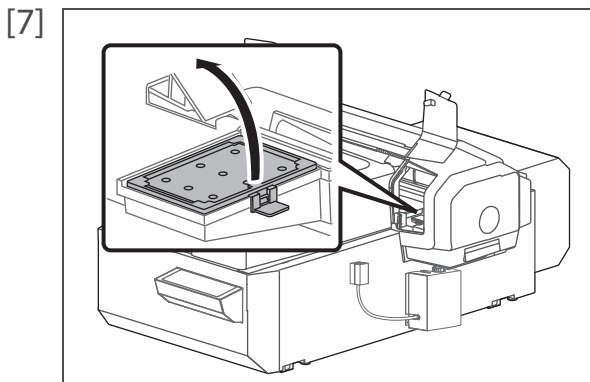

Remove the absorption material for the flushing box.

- Pull the tab up of the absorption material for the flushing box, and release the hook.

**Important!**

**When removing the absorption material for the flushing box, be cautious of ink drops.**

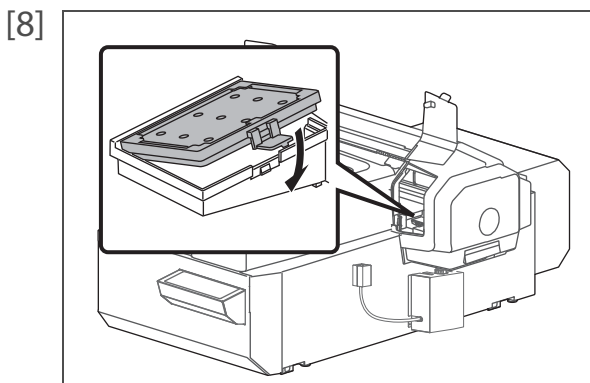

Attach new absorption material for the flushing box.

**Note**

Used absorption material for the flushing box should be put in a plastic bag, etc, and dispose of it in compliance with local ordinance and instructions of local authorities.

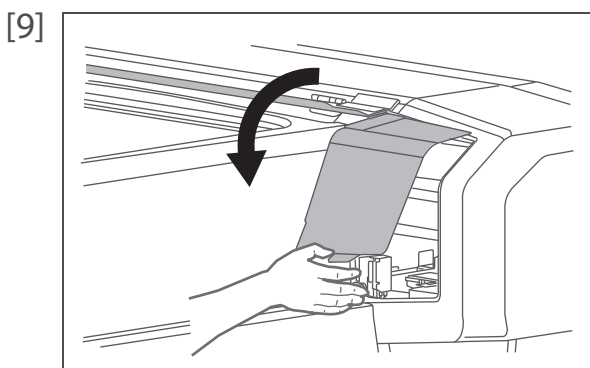

Hold the position shown on the left and gently close the cover.

**CAUTION**



**When closing the maintenance cover, hold the tab on the maintenance cover to gently close it.**

Do not place your fingers on the edges of the printer's opening portion, or on any parts around those edges. Your fingers could get caught and be injured.

[10]

```
CR Maintenance
End          -> Enter
```

```
CR Maintenance
Start       -> Enter
```

Tap [Enter].

- The message on the left will appear.
- That ends the procedure.

# Replacing the cleaning wiper

The cleaning wiper is an essential part to make printing consistent. Please replace it periodically.

## Replacing period:

- Approx. every six months

### CAUTION



**Skin or eye contact with UV curable ink may cause skin inflammation or allergic reaction. When using this product, wear personal protective equipment (supplied gloves or solvent-resistant gloves, goggles or protective eyewear, protective mask, protective clothing) to avoid skin contact with ink.**



**Do not open or close the cover while you are off balance.**  
You may pinch your finger or get injured.

## Replacing steps

[1] Check that the media and jig are removed from the printer.

[2] Tap [Home].

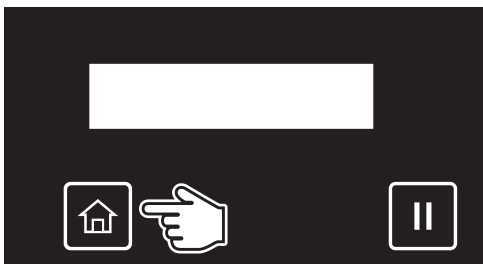

[3] Use  to choose the menu shown left.  
Tap .



[4] Use  to choose the menu shown left.  
Tap .



[5] Tap [Enter].  
• The carriage will move to the left side of the printer.  
• The cleaning wiper will move upward.

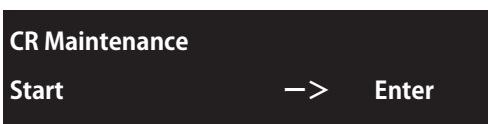

The message on the left will appear.

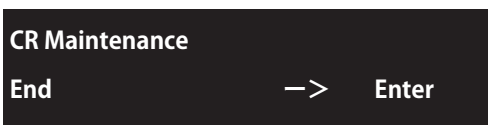

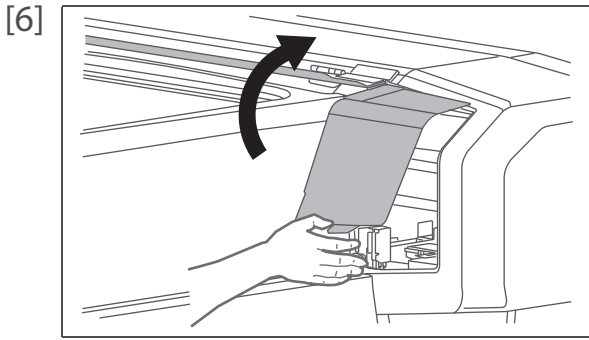

Hold the tab on the maintenance cover as shown on the left to gently open the cover.

- Fully open the maintenance cover.

**CAUTION**



**Always fully open the maintenance cover.**

If you leave it half-open, the maintenance cover can suddenly close.

[7] Remove the cleaning wiper.

- Lift the cleaning wiper hook and release the hook. Then, remove the cleaning wiper.

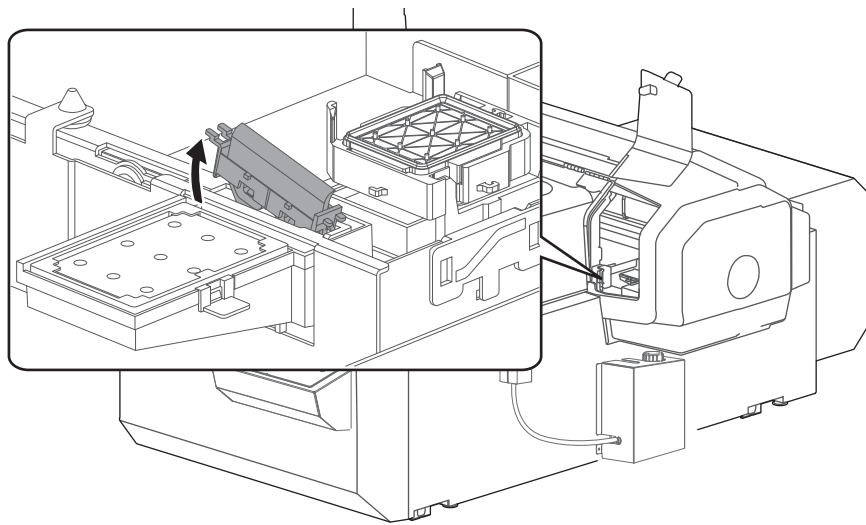

**Important!**

**When removing the cleaning wiper, be cautious of ink drops.**

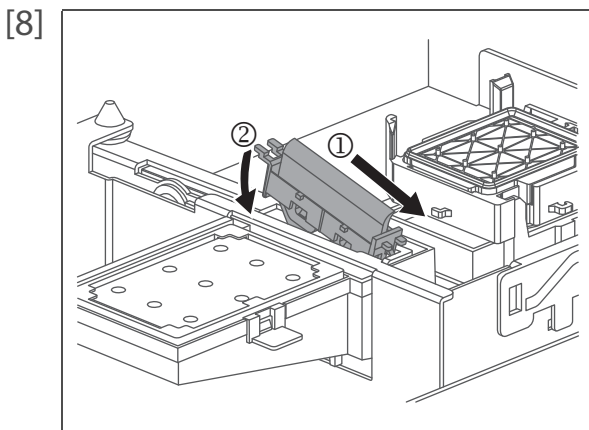

Follow the steps below to install new cleaning wiper.

- Slide the front side of the new cleaning wiper into its slot.
- Press the wiper hook down until it clicks into place.

**Important!**

**Do NOT touch the cleaning wiper rubber with your bare hand. If finger oil gets on the rubber, it will damage the print head.**

**Note**

Used cleaning wiper should be put in a plastic bag, etc, and dispose of it in compliance with local ordinance and instructions of local authorities.



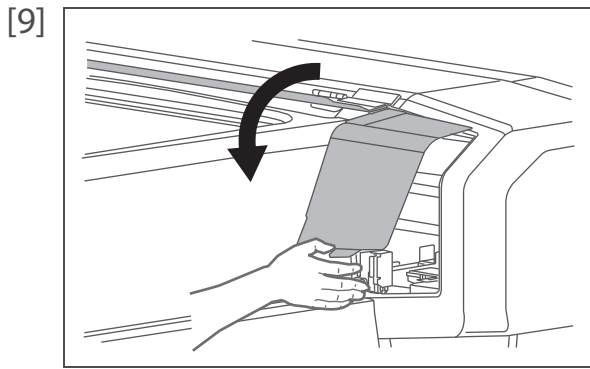

Hold the tab on the maintenance cover as shown on the left to gently close the cover.

**CAUTION**



**When closing the maintenance cover, hold the tab on the maintenance cover to gently close it.**

Do not place your fingers on the edges of the printer's opening portion, or on any parts around those edges. Your fingers could get caught and be injured.

[10]



Tap [Enter].

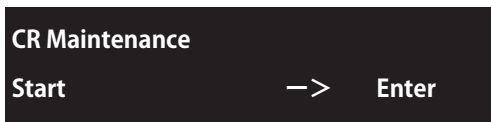

- The message on the left will appear.
- That ends the procedure.

## Replacing the Emitting Window Glass on the UV-LED Lamp

The emitting window glass protects the UV-LED lamp from ink mist. Using the printer with dirty glass will cause damage to the lamp or insufficient ink curing. Replace the glass as needed.

### Replacing period:

- When the glass has cracks or chips.
- When the ink cannot be removed from the glass.

#### CAUTION



**Skin or eye contact with UV curable ink may cause skin inflammation or allergic reaction. When using this product, wear personal protective equipment (supplied gloves or solvent-resistant gloves, goggles or protective eyewear, protective mask, protective clothing) to avoid skin contact with ink.**



#### CAUTION



After printing, the UV-LED lamp may get hot. Leave it for 30 minutes to cool down and then start maintenance.



### Replacing steps

[1] Check that the media and jig are removed from the printer.

[2]  Tap [Home].

[3]  • Use  to choose the menu shown left.  
• Tap .

[4]  • Use  to choose the menu shown left.  
• Tap .

[5]  Tap [Enter].  
• The carriage will move to the left side of the printer.  
• The cleaning wiper will move upward.

 The message on the left will appear.

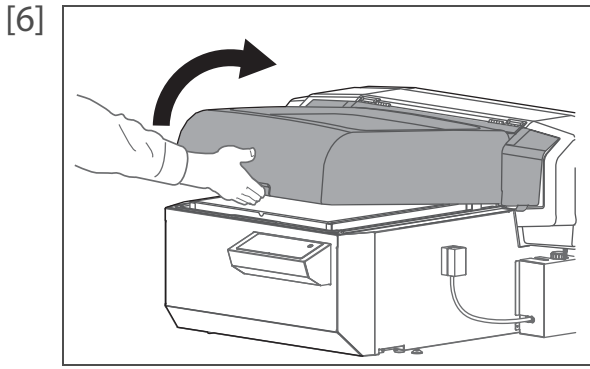

Hold the handle on the front cover to gently open it.

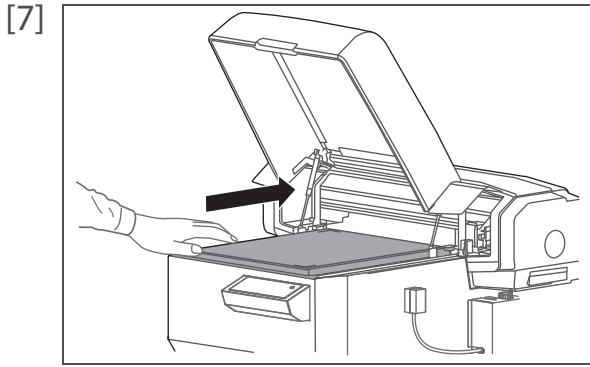

Push the table all the way.

[8] Look in the stainless tray to check the bottom of the carriage.

- Check for cracks, chips, or ink on the emitting window glass of the UV-LED lamp.

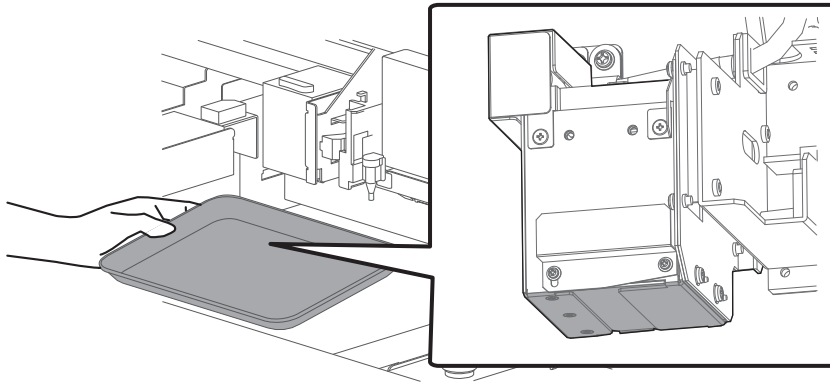

[9] Replace the glass.

- Slide up the left side of the exhaust fan cover. The right side screw serves as a fulcrum.
- Slide the glass on the bottom of the lamp towards the front to remove it.
- Install a new glass on the UV-LED lamp.
- Firmly slide it into the end and then put the exhaust fan cover back in place.

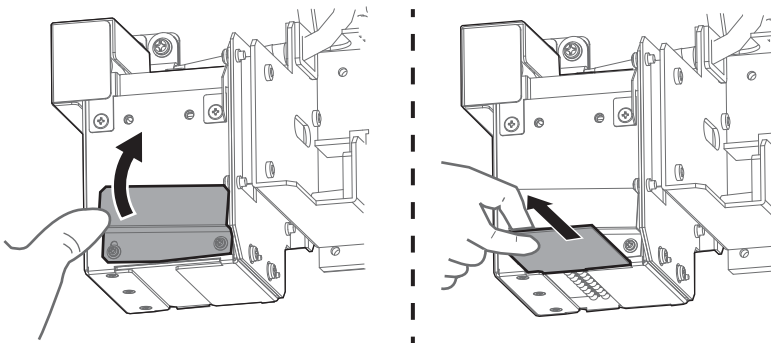

**Important!**

**Make sure that a new glass is attached to the lamp and the exhaust fan cover is put back in place. Using your printer without them will cause damage to the lamp.**

[10] Move the table to the front by hand.

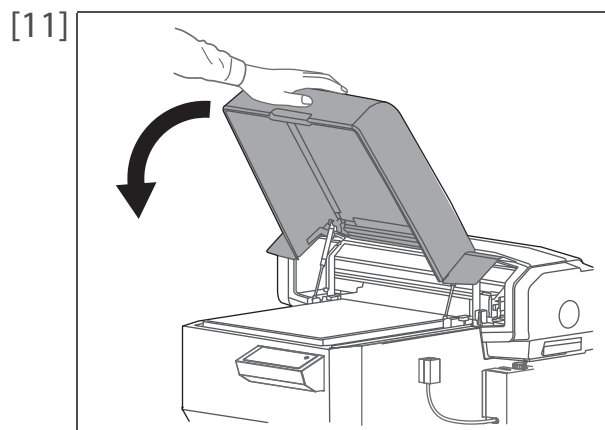

Hold the position shown on the left and gently close the cover.

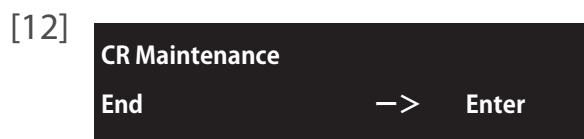

Tap [Enter].

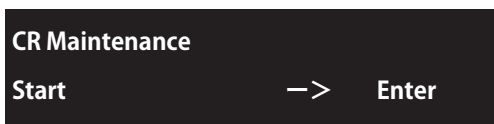

- The message on the left will appear.
- That ends the procedure.

# Replacing UV-LED Lamp Filter

The UV-LED lamp filter protects the lamp from ink mist. Using the printer with dirty filter will cause damage to the UL-LED lamp.

## Replacing period:

- Once a month or when the filter gets dirty by dust or ink.  
(since it differs depending on usage frequency, please check periodically)

### CAUTION



**Skin or eye contact with UV curable ink may cause skin inflammation or allergic reaction.**  
**When using this product, wear personal protective equipment (supplied gloves or solvent-resistant gloves, goggles or protective eyewear, protective mask, protective clothing) to avoid skin contact with ink.**



## Replacing steps

[1] Check that the media and jig are removed from the printer.

[2] Tap [Home].

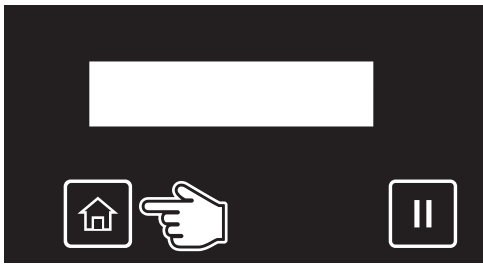

[3] Use  to choose the menu shown left.  
Tap .



[4] Use  to choose the menu shown left.  
Tap .

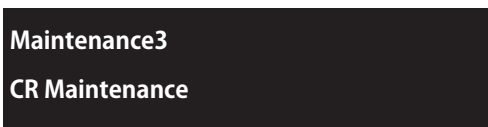

[5] Tap [Enter].  
• The carriage will move to the left side of the printer.  
• The cleaning wiper will move upward.

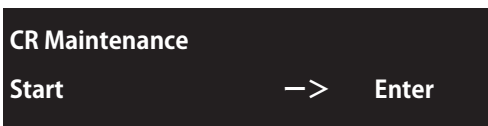

The message on the left will appear.



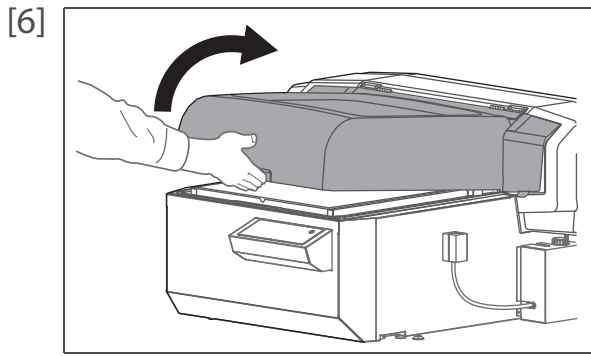

Hold the handle on the front cover to gently open it.

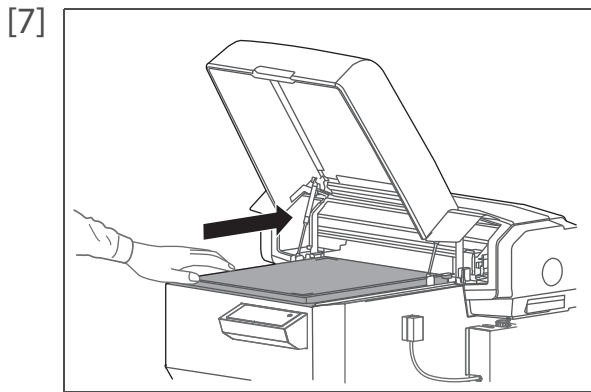

Push the table all the way

[8] While supporting the UV-LED lamp with one hand, remove the filter from the lamp.

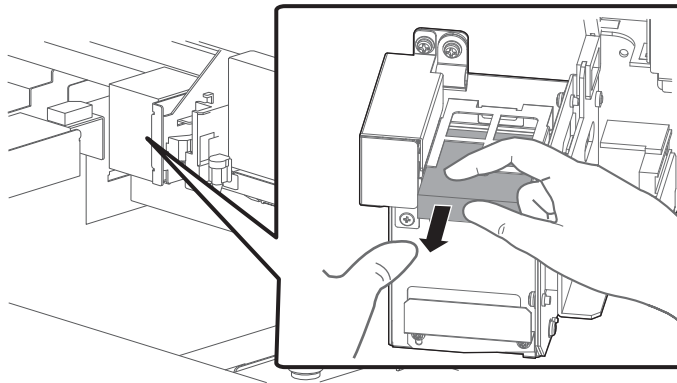

[9] Replace with the new filter.  
• Firmly insert it into the filter slot.

[10] Move the table to the front by hand.

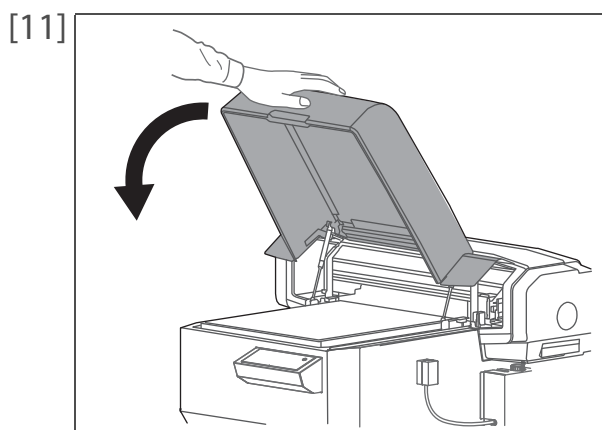

Hold the position shown on the left and gently close the cover.

[12]

CR Maintenance

End                   —>   Enter

CR Maintenance

Start                   —>   Enter

Tap [Enter].

- The message on the left will appear.
- That ends the procedure.

# Moving and Transporting

Please refer to this section when moving or transporting this printer.

## CAUTION



- **This procedure requires four or more people.**
- **Keep this printer level when moving it.**
- **Skin or eye contact with UV curable ink may cause skin inflammation or allergic reaction.**  
**When using this product, wear personal protective equipment (supplied gloves or solvent-resistant gloves, goggles or protective eyewear, protective mask, protective clothing) to avoid skin contact with ink.**

## Important!

- **When moving this product, always empty the waste ink tank even moving short distance.**
- **Do not tilt, or place this product upside down.**  
**Otherwise the ink may leak or the handling mentioned above may cause abnormality.**



## Moving the printer

When moving this printer, it is necessary to empty the waste ink tank.  
Moving without emptying the tank can cause ink leakage.

After moving, reinstall the printer.



### 1. Preparation before moving

---

- [1] Empty the waste ink tank.  
 ["Emptying waste ink tank" P. 124](#)
- [2] Reset the waste ink counter.  
 ["Resetting waste ink counter" P. 127](#)
- [3] Turn the printer OFF, then remove all the cables from the printer.
- [4] Move the printer.

### 2. Installation after moving

---

- [1] Select a suitable place for installation.  
 "Startup Guide"
- [2] Plug cables into the printer.
- [3] Move the printer to the installation area and level the printer.  
 "Startup Guide"
- [4] Perform Nozzle check, and then check that there is no clogging in print head.  
 ["Nozzle check and cleaning" P. 38](#)











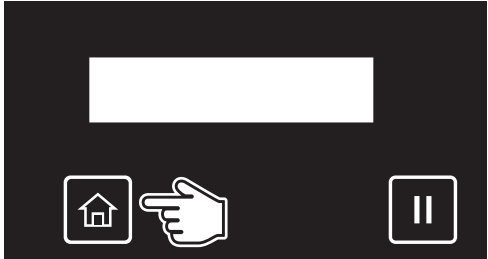



# Transporting

When transporting this product, it is necessary to empty the waste ink tank and fixate the print head and the table with packaging material. Transporting without these steps can cause ink leakage.

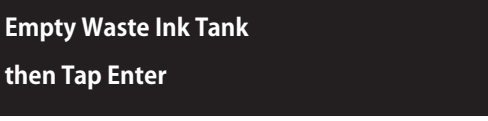
To use the printer again, reinstall the printer and perform initial charging.

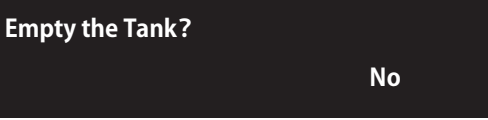
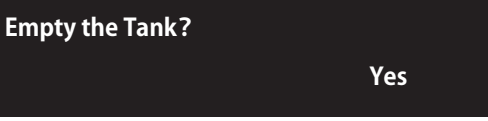
## 1. Discharging the ink in the printer and waste ink

- [1]  Tap [Home].
- [2] 
  - Use  to choose the menu shown left.
  - Tap .
- [3] 
  - Use  to choose the menu shown left.
  - Tap .
- [4]  Tap [Enter].
- [5]  When the message on the left appears, transfer the waste ink into a container.  
 ["Drain waste ink into a container" P. 125](#) Under ["Emptying waste ink tank"](#)
-  The message on the left will appear.
- [6] 
  - Use  to choose the menu shown left.
  - Tap [Enter].
-  The message on the left will appear.

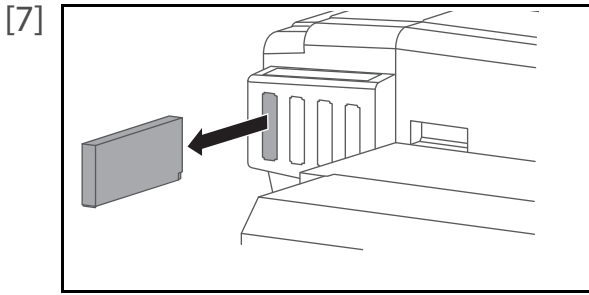

Remove the ink cartridges (or high-capacity ink pack adapters) from all the cartridge slots.



The message on the left will appear.

- Discharging the ink will start.

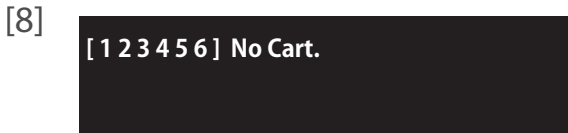

- When the message on the left appears, transfer the waste ink into a container.

["Drain waste ink into a container" P. 125](#) Under ["Emptying waste ink tank"](#)



[9] Reset the waste ink counter.  
["Resetting waste ink counter" P. 127](#)

## 2. Changing Table Position for Packing



Tap [Home].



- Use to choose the menu shown left.
- Tap .

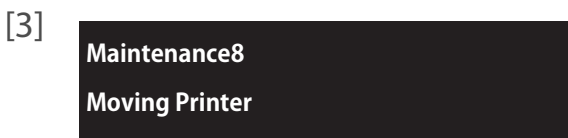

- Use to choose the menu shown left.
- Tap .



The message on the left will appear.



- Use  to choose the menu shown left.
- Tap [Enter].



- The table moves to the front side of the printer.

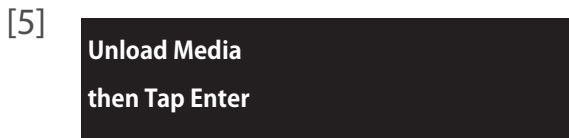

- The message on the left will appear.
- Remove the media and the jig on the table, and then tap [Enter].



- The table moves to the position to secure with shipping brackets.

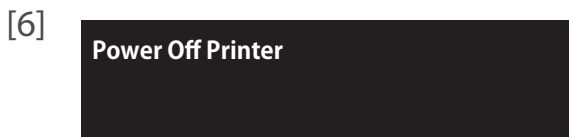

- The message on the left will appear.
- Press the power button to turn OFF the printer.

### 3. Repacking

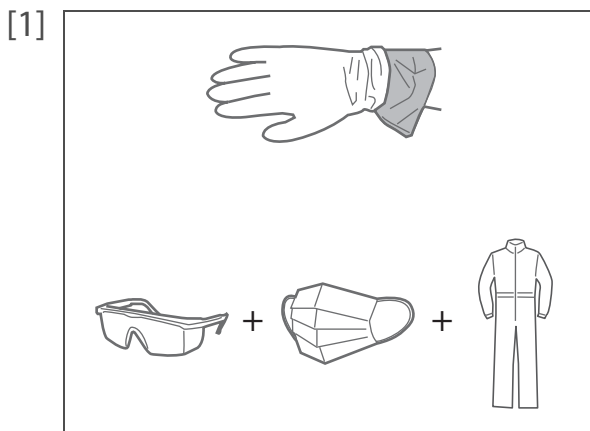

- Wear the rubber gloves over the polyethylene gloves.
- Wear personal protective equipment such as goggles, protective mask or clothing.

[2] Remove all cables from the printer.

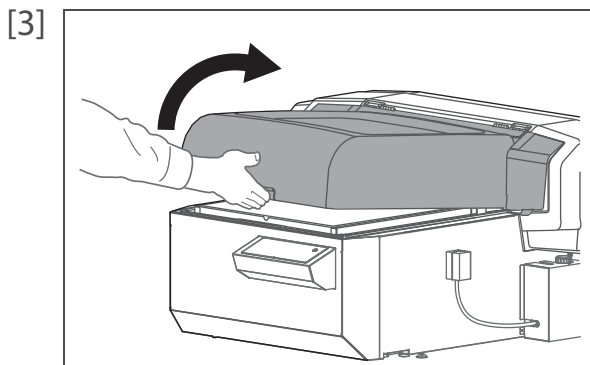

Hold the handle on the front cover to gently open it.

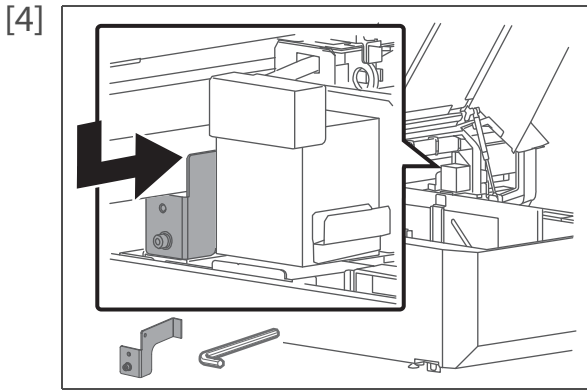

- Attach the head fixing plate with screws.
- Slide the head fixing plate leftward to attach it.
  - Use the hexagon wrench supplied with the printer.

**Important!**

**Attach the head fixing plate carefully, so that it does not scratch any of the surrounding parts. If they are scratched, the print quality could drop.**

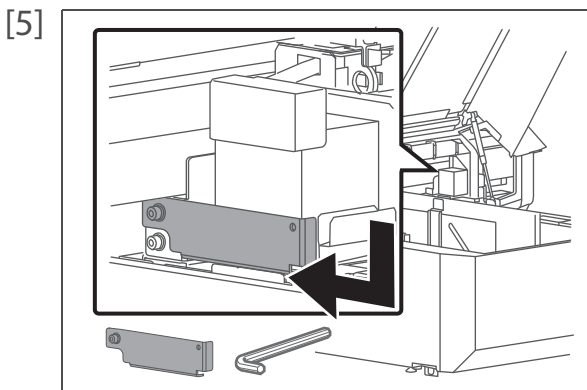

- Attach the UV-LED lamp fixing plate with screws.
- Slide the UV lamp fixing plate in from the front side of the printer until it reaches to the head fixing plate.
  - Use the hexagon wrench supplied with the printer.

**Important!**

**Attach the UV-LED lamp fixing plate carefully, so that it does not scratch any of the surrounding parts. If they are scratched, the print quality could drop.**

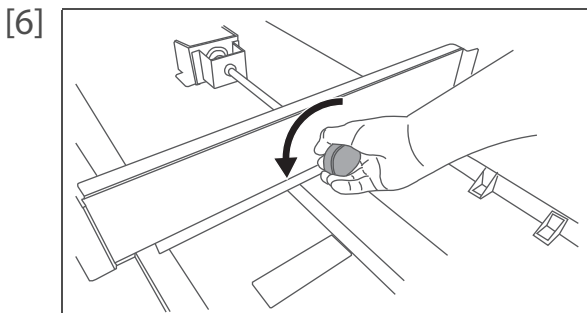

- Turn the handle half rotation anticlockwise.
- It lowers the table.

**Important!**

**DO NOT turn the handle too much. It can cause damage to the printer.**

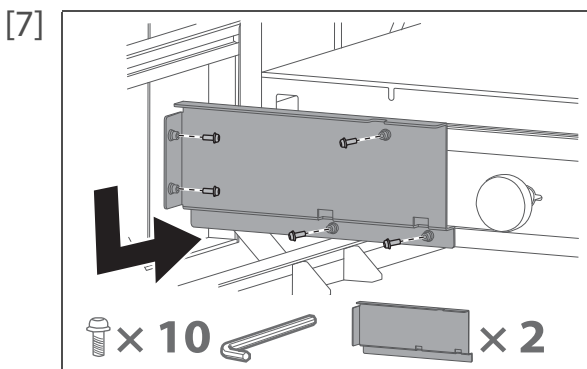

- Attach two table fixing plate with screws.
- Use the hexagon wrench supplied with the printer.

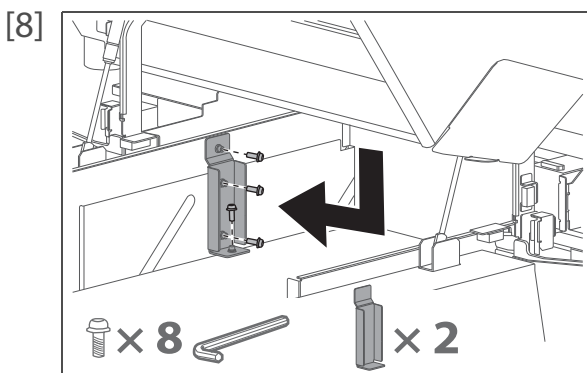

- Attach two table fixing plate with screws.
- Use the hexagon wrench supplied with the printer.

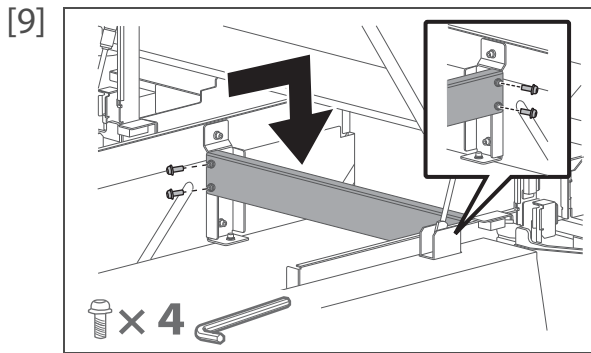

Attach the support brace between table fixing plates with screws.

- Use the hexagon wrench supplied with the printer.

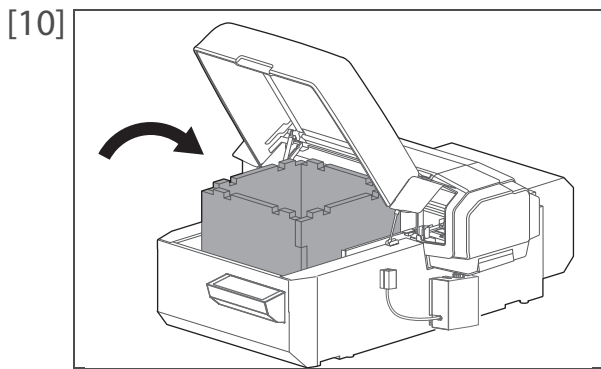

Put the protective material on the table.

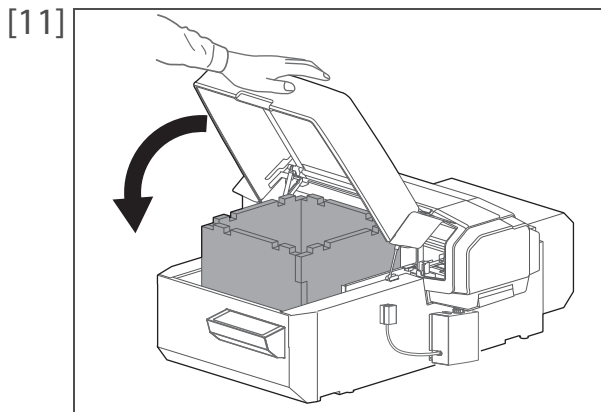

Hold the position shown on the left and gently close the cover.

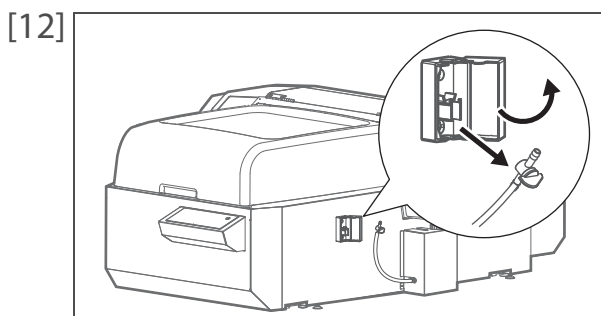

Open the cover of the drain tube valve clamp, then unhook the drain tube valve to take it out from the clamp.

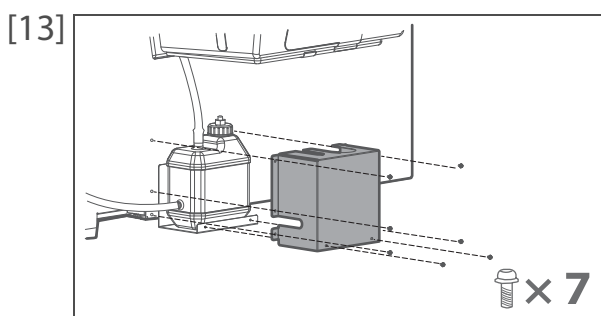

Remove seven screws (M3x6) on the waste ink tank cover to remove the cover from the printer.

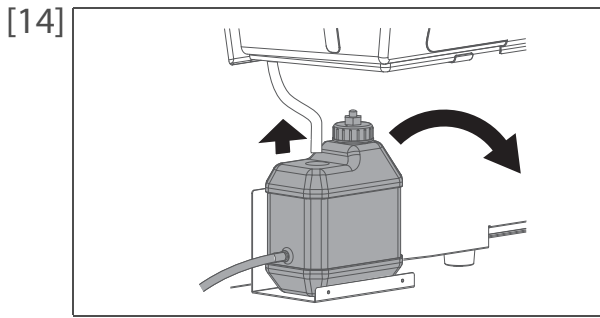

Remove the waste ink tank.

- Remove the drain tube from the tank.
- Remove the waste ink tank from the tank holder.

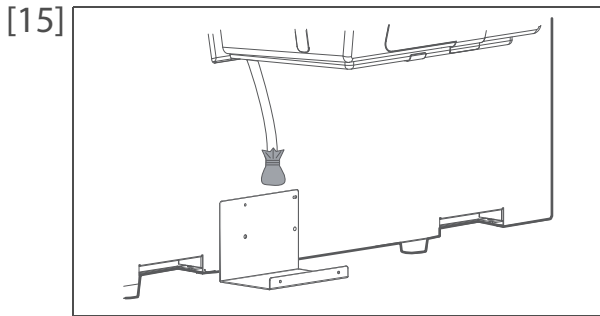

To prevent waste fluid from dripping, cover the tip of the tube with a plastic bag and secure with tape.

[16] Remove two screws (M3x6) on the two-way valve clamp to remove the clamp from the printer.

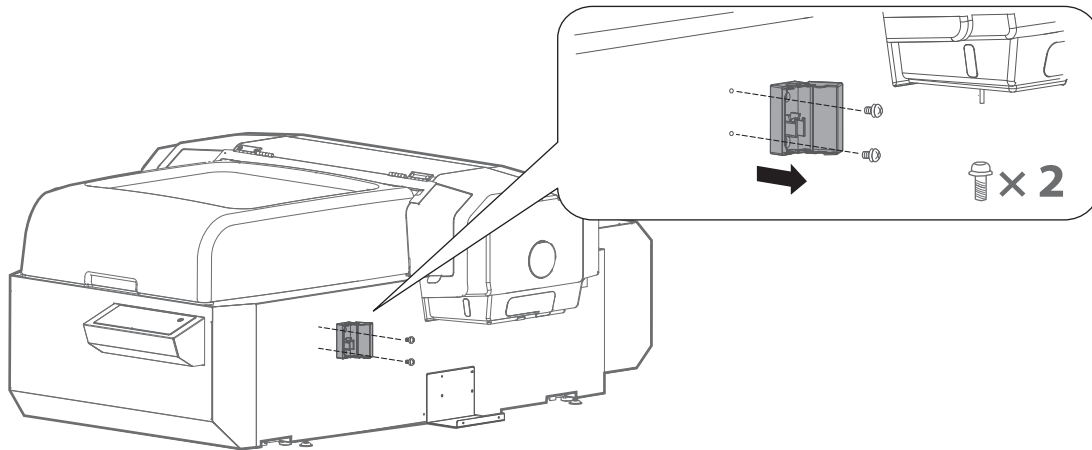

- [17] Remove four screws (M3x6) on the waste ink tank holder to remove the holder from the printer.

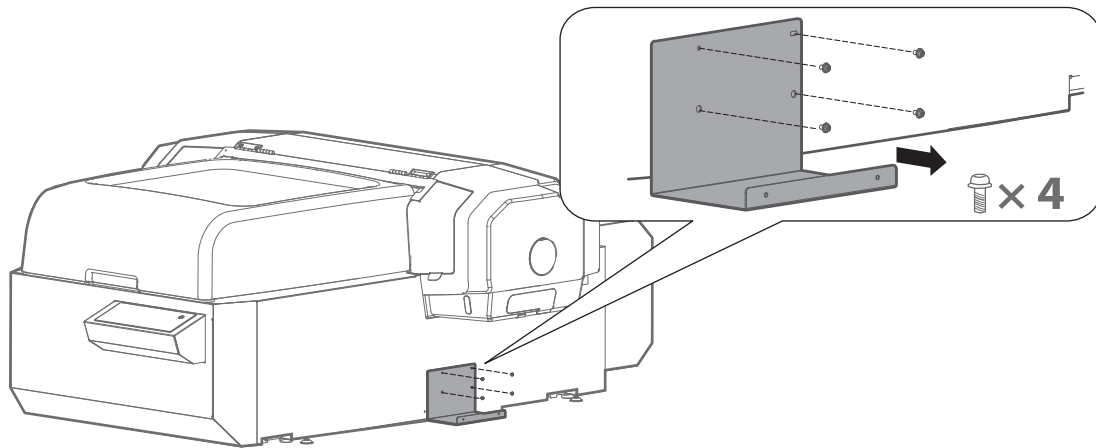

- [18] Attach protection materials, and place the product inside the package box.

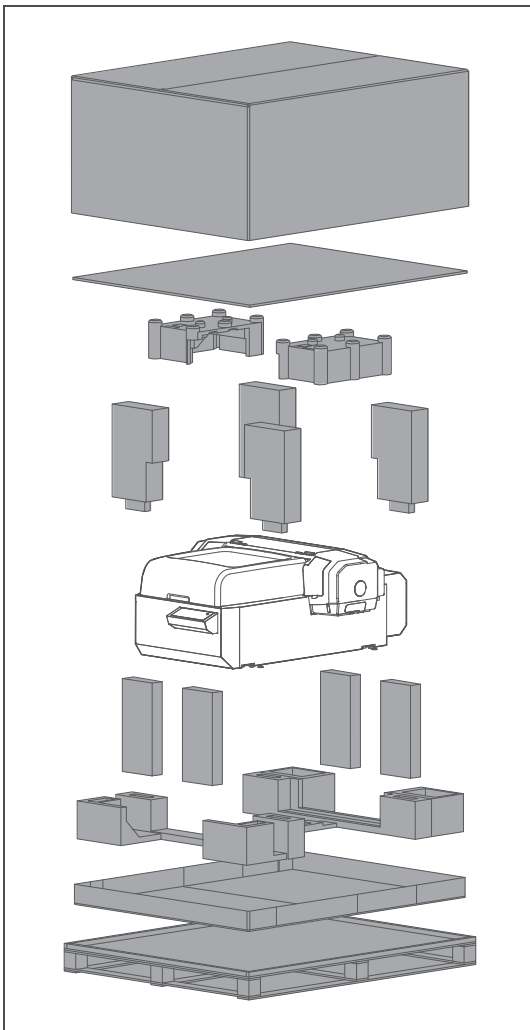

## 4. Reinstalling

- [1] Referring to "Startup Guide", unpack the product and assemble.  
• Conduct up to "Leveling Printer".

- [2] Carry out initial ink charging after ink discharge.

 ["How to perform initial ink charging after ink discharge" P. 168](#)

## How to perform initial ink charging after ink discharge

[1]

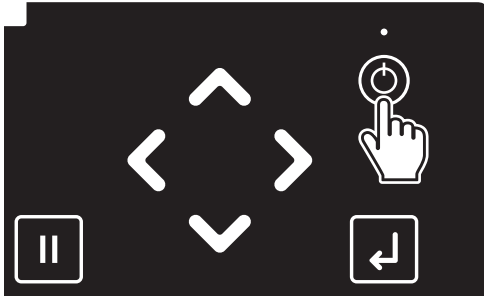

Long press the Power button.

- The keys on the operation panel light up.
- The printer will start mechanical initialization.

[2]



Tap [Enter] when the message on the left appears.

[3]

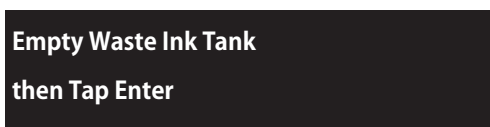

When the message on the left appears, empty the waste ink tank.

 ["Drain waste ink into a container" P. 125](#) under ["Emptying waste ink tank"](#)

[4]

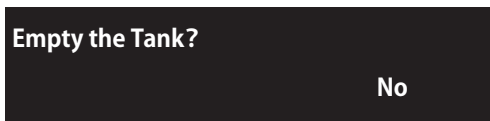

The message on the left will appear.

[5]

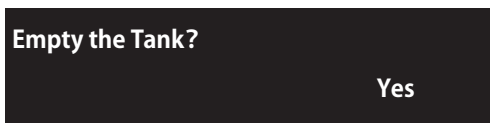

- Use  to choose the menu shown left.
- Tap [Enter].

### Note

(When you use your printer for the first time or after you replace the waste ink tank) If no or small amount of waste fluid is collected in the waste ink tank, you may not be able to drain fluid out of the tank.

The message on the left will appear.

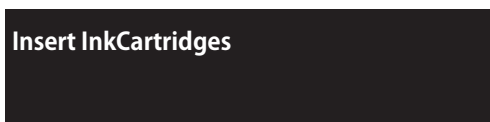



## Procedure for ink cartridge

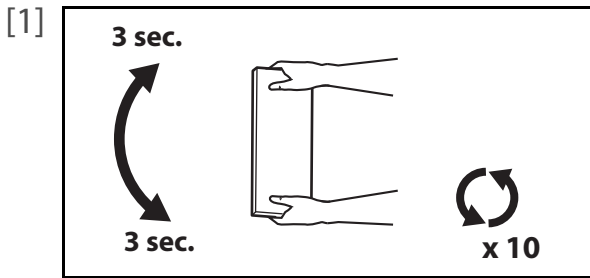

Make sure you agitate the ink cartridge after you unpack it.

- Turn the ink plug upward and wait for three seconds.
- Next, turn the ink plug downward and wait for three seconds.
- Repeat that 10 times.



- You do not have to agitate varnish ink before use.

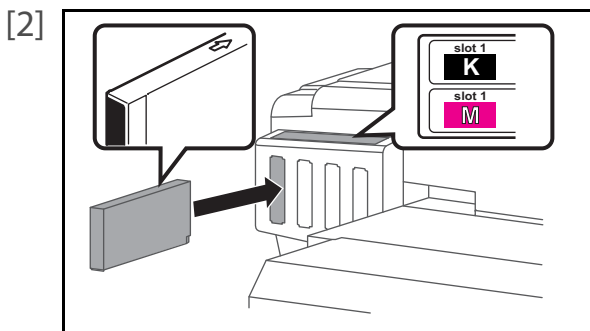

Insert ink cartridge to this product.

- Match the label of this product to the color of ink cartridge.
- The arrow on the cartridge should face up.
- Insert each cartridge to firmly seat it into each slot.



**Load the same ink color configuration as before.**

## Procedure for high-capacity ink pack adapter

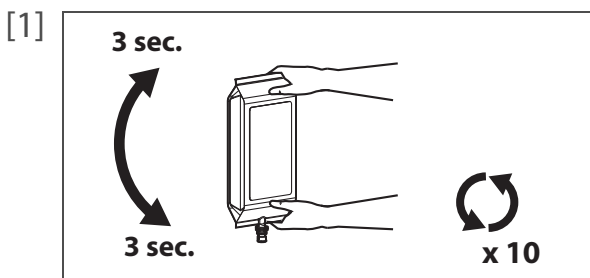

Make sure you agitate the ink bag after you prepare it.

- Turn the ink plug upward and wait for three seconds.
- Next, turn the ink plug downward and wait for three seconds.
- Repeat that three times.



When replacing varnish ink, you do not have to agitate it.

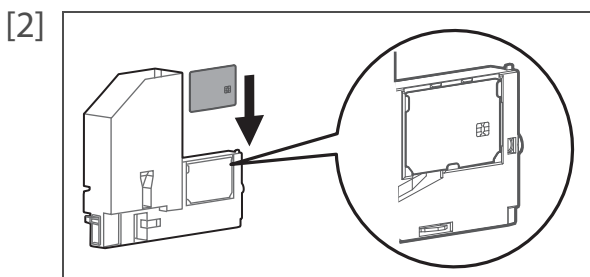

Slide the smartchip card into the tabs of the adapter.

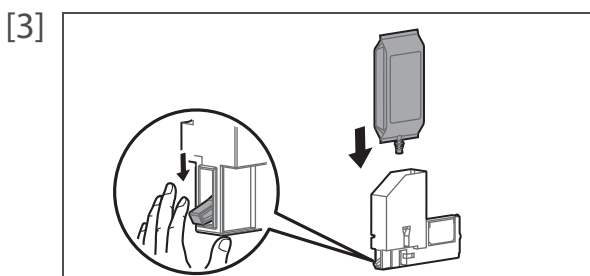

While lowering the lock lever of the high capacity ink pack adapter, insert an ink bag.

- Make sure to fully insert the ink bag into the high capacity ink pack adapter.

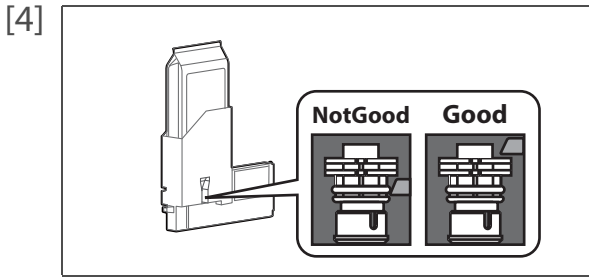

Confirm ink bag is fully seated by checking the lock mechanism is at the top of the ink delivery neck through the observation window, see proper placement in illustration left.

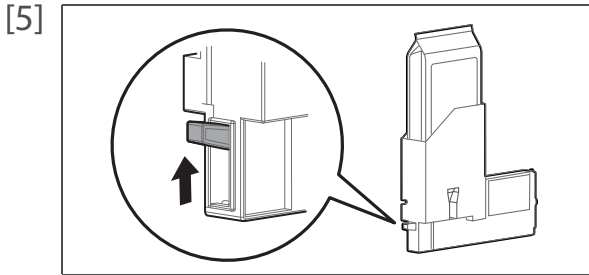

Make sure that the lock lever of the high capacity ink pack adapter is back to its original position.

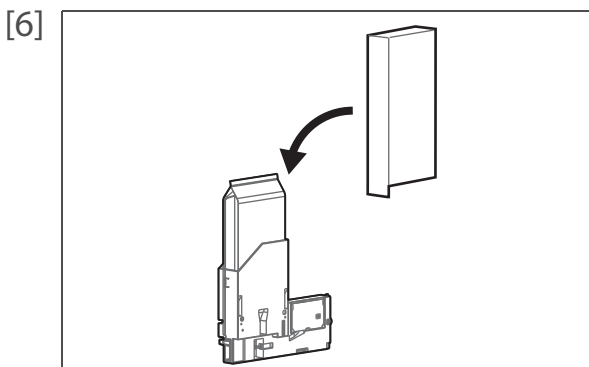

Place the light-shielding cover over the ink bag.



**Note**

Insert the light-shielding cover inside the high capacity ink pack adapter to only cover the ink bag.

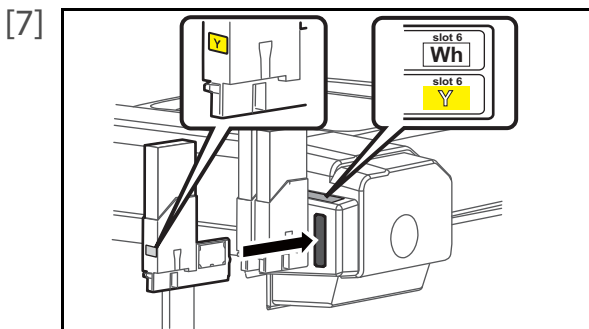

Insert the high capacity ink pack adapters into Ink cartridge slots.

- Make sure to match the ink color with the color of the label above the cartridge slot.
- Insert all the way to the end.



**Important!**

**Load the same ink color configuration as before.**

### Ink charging procedure after loading ink cartridges



The message on the left will appear.

- This printer starts ink charging.

**CAUTION**



**DO NOT attempt the following actions during ink charging:**

- Power off the printer.
- Disconnect the power cord.
- Open the front cover and maintenance cover.

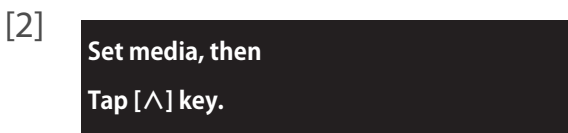

When ink charging is complete, the message on the left will appear.

# Chapter 4 Appendix

Messages and Error Messages .....	172
Status messages .....	172
Error message display and possible solutions .....	173
Error requiring restart .....	176
Troubleshooting .....	177
Installation and initial setup troubleshooting .....	177
Boot-up troubleshooting .....	178
Media-related troubleshooting .....	178
Table-related troubleshooting .....	179
Printing-related troubleshooting .....	180
Specifications of this product .....	183
List of specifications .....	183
Options / Supply list .....	185
Revision History .....	185

# Messages and Error Messages



This section describes messages displayed during normal printer operation or when errors occur, and solutions to the messages.

## Status messages

This section describes messages displayed during printer normal operation.

When the product is operating correctly, each operation status is displayed on the front panel as below.

Display	Description
Activation required	Activation has not been executed. Consult the relevant section of the Startup Guide, and carry out activation.  <a href="#">Startup Guide "Step1 Carrying out activation"</a>
Ready to Print	Standby (Media is loaded).
Set media, then tap [^] Key	Standby (Media is not loaded).
Receiving	Receiving data.
Converting	Analyzing data.
Printing	Under printing.
Remain : XXX.Xm	Displays the length of the data that has not been printed in meters for the data currently being printed.
Remain Time : XXX.Xmin	Displays the time remaining to print in minutes for the data currently being printed.
Pausing Print Cancel Print -> Enter	Printing is paused. · Tap [Cancel] to resume printing. · Tap [Enter] to cancel printing. (Once canceled, you cannot resume the job again.)
Power Off	Turning OFF the printer. Please wait for a while.
S/C Reading	Reading the smartchip card.
Ink Circulation	Ink is circulating inside the printer.
*** Remote Mode ***	The remote panel mode is running, via MSM or similar. In the remote panel mode, operations via the operation panel are not possible. To terminate the remote panel mode, tap [Cancel] for more than two seconds.
Ink Charge Start -> Enter	Ink charging starts. Tap [Enter].
Insert Cleaning Cart.	Washing print head. Install the cleaning cartridges.
Busy-Washing **%	· Initial charging, ejecting filler fluid. · Washing the print head by cleaning fluid. Please wait a while.
Remove Cartridges	Washing print head or discharging ink. Remove the ink cartridges (or high-capacity ink pack adapters).
Insert Ink Cartridges	Charging ink. Insert ink cartridges (or high-capacity ink pack adapters).
Ink Refill **%	Charging ink. Please wait a while.





Display	Description
Discharging	Discharging ink. Please wait a while.
Empty Waste Ink Tank then tap Enter	Transfer the waste ink from the waste ink tank into a container, and tap [Enter].  <a href="#">"Emptying waste ink tank" P. 124</a>
Perform Daily Maint.	Make sure to perform daily maintenance when prompted.  <a href="#">"Clean daily maintenance parts" P. 139</a>



## Error message display and possible solutions

This section describes error messages and possible solutions.

Error messages are displayed when certain failures occur during printer operation.

If an error that can be displayed occurs, the printer may display the following error messages on the operation panel and stop operation.

Display	Description
Cover Open	The front cover is open.
Maint. Cover Open	The maintenance cover is open.
[*****] Ink End	Ink has run out. (Stops operation) Replace with a new ink.  <a href="#">"Replacing ink" P. 120</a>
[*****] NoCartridge	Ink cartridge (or high-capacity ink pack adapter) is not inserted. (Stops operation) Insert an ink cartridge (or high-capacity ink pack adapter).
[*****] Discharged	Ink is not filled. Perform initial ink charging.  <a href="#">"How to perform initial ink charging after ink discharge" P. 168</a>
Full WasteInkTank	The waste ink tank has become full. (Operation will stop when this happens.) Immediately transfer the waste ink into a container.  <a href="#">"Emptying waste ink tank" P. 124</a>
NearFullWasteInkTank	The waste ink tank is about to become full. (Operation will continue in this condition.) Transfer the waste ink into a container.  <a href="#">"Emptying waste ink tank" P. 124</a>
[*] Ink Low	Slot * ink is low. Get a replacement ink ready.
[*****] S/C ReadErr	Failed to read the smartchip card. Insert the ink cartridge (or high-capacity ink pack adapter) again. If the problem persists, insert a new ink cartridge (for high-capacity ink pack adapter, insert a new smartchip card and a new ink bag into the adapter).
[*****] S/C Col.Err	Wrong ink color. Insert a correct ink color cartridge (or ink bag).
[*] S/C Ink Err	The ink installed cannot be used for this printer. Contact your local MUTOH dealer.
[*] S/C CodeErr	Inserted ink cartridge (or smartchip card in case of high-capacity ink pack adapter) is not a proper one. Contact your local MUTOH dealer.

Display	Description
[*] Broken Chip	Smartchip card has been broken. Insert a new ink cartridge (or a new smartchip card and a new ink bag for high-capacity ink pack adapter).
[*****] Check Ink	Ink cartridges (or high-capacity ink pack adapters) were not recognized correctly. Insert ink cartridges (or high-capacity ink pack adapters) correctly again. Contact your local MUTOH dealer.
[*]Reseat Ink	Because the smartchip card is poor in contact, the reinsertion of the ink cartridge (or the high-capacity ink pack adapter) is necessary. Reseat all the ink cartridges (or the high-capacity ink pack adapters).
Daily Maint. Error	An obstacle has been detected. Press any key on the operation panel. Remove any object including a jig from the table and then perform daily maintenance.
Obstacle detected Press [✓] Key.	An obstacle has been detected. Tap  , and reset the media in place.  <a href="#">"Loading media" P. 33</a>
Table Height Error Tap [✓] key.	The printer cannot lower the table any further as specified by RIP software, and will cancel the printing.
Obstacle Detected Print Cancel	An obstacle has been detected. Tap [Enter] to cancel the job.
Obstacle Detected Print Continue	An obstacle has been detected. Tap [Enter] to resume the job.
Activation Failed Reboot Printer	Activation has failed. Restart the printer and activate the printer again.
Life Times [Pump]	The operational life of the pump motor has almost expired. (Continues operation) Contact your local MUTOH dealer.
Life Times [CR Motor]	The operation life CR motor has almost expired. (Continues operation) Contact your local MUTOH dealer.
Life Times [PF Motor]	The operational life of the PF motor has almost expired. (Continues operation) Contact your local MUTOH dealer.
Life Times [C Pump]	The operational life of Circulation pump motor is almost expired. (Continues operation) Contact your local MUTOH dealer.
Life Times [UV Lamp]	The operational life of UV LED has almost expired. (The operation continues.) Contact your local MUTOH dealer.
Agitate W Ink	Agitate the White (Wh) ink.
Agitate KMCY Ink	Agitate the Black (K), Magenta (M), Cyan (C), and Yellow (Y) inks.
Agitate KMCYW Ink	Agitate the Black (K), Magenta (M), Cyan (C), Yellow (Y), and White (Wh) inks.
Agitate ALL Ink	Agitate all inks. Agitate the Black (K), Magenta (M), Cyan (C), and Yellow (Y) inks.
Ink Not Expired? OK -> Enter	Check the "Use Before" date on the cartridge (or ink bag) label.

 Note

- The color inside [\*\*\*\*\*] in the error display represents the ink color with a problem.
- If no ink and no cartridge occur at the same time, no cartridge message has priority to be displayed.

## Smartchip recovery

---

When the following message is prompted on the operation panel, a smartchip error such as broken chip may have occurred in the ink cartridge.

Check that the correct color is inserted in the cartridge slot and perform smartchip recovery.

This will allow you to continue to print.

To perform smartchip recovery, do one of the followings according to the message appeared.

Display	Description
[***] S/C Recog. Err.	<p>An ink cartridge (or high-capacity ink pack adapter) that needs smartchip recovery may have been installed.</p> <p>Remove the ink cartridge (for high-capacity ink pack adapter, remove the high-capacity ink pack adapter and the smartchip card) and reload it.</p> <p>If the printer is still unable to read it, install a new ink cartridge (for high-capacity ink pack adapter, install a new ink bag and a new smartchip card).</p> <ul style="list-style-type: none"><li>• If a message "[***] Check Color OK -&gt;Enter" appears after the ink cartridge (or high-capacity ink pack adapter) is reloaded, follow the message "[***] Check Color OK -&gt;Enter" to operate.</li></ul>
[***] Check Color OK ->Enter	<p>An ink cartridge (or high-capacity ink pack adapter) that needs smartchip recovery may have been installed.</p> <p>Check that the ink color of the ink cartridge (or ink bag) inserted is correct.</p> <ul style="list-style-type: none"><li>• In case of wrong color insertion, load a correct ink color cartridge (or bag).</li><li>• If color is correct, tap [Enter] key. The printer will perform smart chip recovery and will continue to print.</li></ul>

### Note

- During smartchip recovery execution, the cartridge slot being recovered blinks in the ink level indicator and printer status menu.

 ["Icon displays on operation panel" P. 11](#), ["Printer Status 1: Ink" P. 102](#)

## Error requiring restart

An error requiring restart is displayed if a fatal operational failure such as the following occurs.

- When an obstacle that prevents printing occurs.
- When a problem occurs with the electrical circuit (PCB, motor, sensor, etc.) of the printer.
- When a failure in the printer control program occurs.

If an error requiring restart occurs, the printer stops operating after performing the following operations.

1. The drive power automatically shuts down.
2. All LED lights on the operation panel blink and the printer beeps continuously.
3. The error message is displayed on the operation panel.

Pressing any key on the operation panel stops the beeping.

For an error requiring restart, operation will return to normal after removing the cause of the error and restarting the printer.

If the same error message is repeatedly displayed, contact the your local MUTOH dealer.

Be sure to tell us the code no. of the error message when you contact us.

Display	Description
Emergency Mode: E ***	A problem that does not have a remedy has occurred. 1. Check if the replaced parts are installed correctly. 2. Turn the power button off. Wait a short while, then turn the power button on, to restart the printer.
Emergency Mode: AC	The power was shut down instantaneously while the printer is operating. 1. Turn the power button off. Wait a short while, then turn the power button on, to restart the printer.
Emergency Mode: CPU	CPU error occurred. 1. Turn the power button off. Wait a short while, then turn the power button on, to restart the printer.



### Note

" \*\*\* " in the error message is the code no. that indicates what type of error occurred.





# Troubleshooting

This section describes undisplayed malfunctions and failures of the printer, possible causes and countermeasures.

## Note

- The current status and error information of your printer can be checked from the Printer Status tab > Status Information on MSM.  
If your printer is not operating correctly, check this Status Information first.
- Make sure to use the latest version of MSM.  
To check the latest available version, go to Help > Version > Check for updates on MSM.  
If old version is installed in your computer, download the latest version from MUTOH Club.  
 [MUTOH Status Monitor Operation Manual](#)

## Installation and initial setup troubleshooting



Symptom	Possible cause and remedy
<b>Cannot perform the initial ink charging.</b>	<b>Is the front cover, or the maintenance cover open?</b> <ul style="list-style-type: none"><li>• Close the front cover, or the maintenance cover.</li></ul>
	<b>Are ink cartridges (or high-capacity ink pack adapters) inserted all the way into the printer?</b> <ul style="list-style-type: none"><li>• Make sure they are all inserted properly.</li></ul>
<b>Ink does not come out after ink charging.</b>	<b>Is the ink cartridge (or ink bag) too cold?</b> <ul style="list-style-type: none"><li>• Leave it at room temperature for at least three hours, and perform cleaning several times.  <a href="#">"Head cleaning" P. 137</a></li></ul>
	<b>Is the power turned OFF during ink charging?</b> <ul style="list-style-type: none"><li>• Turn the power ON again and continue ink charging.</li></ul>
<b>Nozzle missing occurs after initial ink charging.</b>	<b>Did you perform head cleaning?</b> <ul style="list-style-type: none"><li>• Perform cleaning, then, check the print result.  <a href="#">"Head cleaning" P. 137</a>, <a href="#">"Maintenance 1: Cleaning" P. 96</a></li><li>• If there is no improvement in the print result even after performing cleaning, leave the printer unused for an hour or more. Then perform cleaning or "Little Charge" again and check the print result.</li><li>• If the problem still persists, contact your local Mutoh dealer.</li></ul>
	<b>Is Ethernet cable connected correctly?</b> <ul style="list-style-type: none"><li>• Securely connect the Ethernet cable to the Ethernet Port.</li></ul>
<b>MSM or RIP cannot access to the printer.</b>	<b>Are the network settings configured correctly?</b> <ul style="list-style-type: none"><li>• Configure the network settings correctly.</li></ul>
	<b>Do the printer's network settings match the computer's settings?</b> <ul style="list-style-type: none"><li>• Match this product's network settings with the computer side environment.  <a href="#">"Initial Settings 4: IP Address" P. 91</a>, <a href="#">"Initial Settings 5: Subnet Mask" P. 91</a>, <a href="#">"Initial Settings 6: Gateway" P. 92</a></li></ul>

## Boot-up troubleshooting



Symptom	Possible cause and remedy
<b>Does not work at all after power activation /after loading the media.</b>	<b>Is the power cable connected to the plug?</b> <ul style="list-style-type: none"><li>• Connect the power cable.</li></ul>
	<b>Does the AC power supply provide the specified voltage?</b> <ul style="list-style-type: none"><li>• Connect the cable to another outlet.</li></ul>
	<b>Is the front cover, or the maintenance cover open?</b> <ul style="list-style-type: none"><li>• Close the front cover, or the maintenance cover.</li></ul>
	<b>Is there any error message displayed on MSM?</b> <ul style="list-style-type: none"><li>• Go to the Printer Status tab in MSM and check that if any error message is displayed in the Status Information.</li></ul>
	<b>Do you use the printer within recommended environmental conditions?</b> <ul style="list-style-type: none"><li>• Make sure to use the printer within the specification range.</li></ul> <p> <b>"Ensuring a suitable place for installation" of the "Startup Guide"</b></p>



## Media-related troubleshooting

Symptom	Possible cause and remedy
<b>The printer does not detect the media.</b>	<b>Is there any media or jig present on the table height detection area?</b> <ul style="list-style-type: none"><li>• DO NOT place any objects in this area. Otherwise, it will cause false detection of the obstacle sensor and the printer may not be able to print correctly.</li></ul>
	<b>Do you use transparency or low opacity media?</b> <ul style="list-style-type: none"><li>• The sensor may not detect those media. Make sure that the sensor correctly detects the media being used.</li></ul>
	<b>Do you use textured media or uneven media?</b> <ul style="list-style-type: none"><li>• The sensor detects the highest position on the media as media surface. The printer may not be able to print properly.</li></ul> <p> <b>"Cautions for handling media" P. 18</b></p>
	<b>Do you use the media with uneven or curved bottom surface?</b> <ul style="list-style-type: none"><li>• The laser light will not be blocked by the rear edge of media so that the printer may not be able to optimize the table height.</li></ul>



Symptom	Possible cause and remedy
<b>Print head strikes media while printing.</b>	<p><b>Is the media loaded correctly?</b></p> <ul style="list-style-type: none"> <li>Load the media correctly.</li> </ul> <p> <a href="#">"Requirements for usable media" P. 18</a>, <a href="#">"Loading media" P. 33</a></p>
	<p><b>Is any wrinkles present on the media?</b></p> <ul style="list-style-type: none"> <li>Smooth out the media to sit flat on the table.</li> </ul>
	<p><b>Is warp, fold or curl present on your media?</b></p> <ul style="list-style-type: none"> <li>Follow the instructions in <a href="#">"Cautions for handling media" P. 18</a></li> <li>If media does not sit flat on the table, secure it on the table using a thin tape to avoid any warps.</li> </ul>
	<p><b>If you are using the optional vacuum table, is the vacuum fan power appropriate for the media being loaded?</b></p> <ul style="list-style-type: none"> <li>If media warps, change the vacuum fan setting higher to reduce the chance of warp.</li> </ul> <p> <a href="#">"Loading media" P. 33</a>, <a href="#">"&gt;5: Vacuum Fan" P. 75</a></p> <ul style="list-style-type: none"> <li>If it does not help, cover the vacuum holes around the media with papers to increase suction power.</li> </ul>
	<p><b>Is there any curls on the media while printing?</b></p> <ul style="list-style-type: none"> <li>While printing, media may curl by UV lamp or ink curing. Use heat-resistant media or use a jig to prevent curls.</li> </ul> <p> <a href="#">"Cautions for handling media" P. 18</a></p>











## Table-related troubleshooting









Symptom	Possible cause and remedy
<b>Noise occurs while the table moves up and down./ Table does not move and noise is present.</b>	<p><b>Do you perform table maintenance as instructed?</b></p> <ul style="list-style-type: none"> <li>Apply lubricating grease on the table screw shaft.</li> </ul> <p> <b>Note</b></p> <p>Perform this maintenance once a month.</p>
	<p><b>Did you place a small and heavy media or jig on either end of the table?</b></p> <ul style="list-style-type: none"> <li>If you are using those items, place it as close to the center of the table as possible.</li> </ul> <p> <a href="#">"Requirements for usable media" P. 18</a></p>
	<p><b>Is total weight of media and jig within 6kg?</b></p> <ul style="list-style-type: none"> <li>The maximum weight on the table is 6 kg.</li> <li>Remove items on the table and reboot the printer.</li> </ul> <p> <a href="#">"Requirements for usable media" P. 18</a></p> <ul style="list-style-type: none"> <li>If the problem still persists, please contact your local Mutoh dealer.</li> </ul>

Symptom	Possible cause and remedy
Abnormal noise from the table when loading media.	<p>Depending on the size or position of the media placed on the table, an abnormal noise may occur.</p> <ul style="list-style-type: none"> <li>If you hear an abnormal noise, cover all the holes around the media with paper or thin materials.</li> </ul> <p> <b>Important!</b></p> <ul style="list-style-type: none"> <li><b>To cover the holes, avoid objects thicker than the media to be printed. The printer may not be able to print properly.</b></li> <li><b>When covering the holes, DO NOT place any objects in the table height detection area. Otherwise, it will cause false detection of the obstacle sensor and the printer may not be able to print correctly.</b></li> </ul> <p> <a href="#">"Printing area" P. 32</a></p>
The print head hit the media and the jig while printing.	<p>Is there any media or jig placed in the area in front of the guide groove on the front side of the table?</p> <ul style="list-style-type: none"> <li>This area is outside the sensing area of the obstacle detection sensor. Do not place any object thicker than the media being loaded. This will cause head strike leading to damage to the print head.</li> </ul> <p> <a href="#">"Printing area" P. 32</a></p>

## Printing-related troubleshooting

Symptom	Possible cause and remedy
<b>The printer does not print.</b>	<p><b>Is Ethernet cable connected correctly?</b></p> <ul style="list-style-type: none"> <li>Securely connect the Ethernet cable to the Ethernet Port.</li> </ul> <hr/> <p><b>Is there any error message displayed on MSM?</b></p> <ul style="list-style-type: none"> <li>Go to the Printer Status tab in MSM and check that if any error message is displayed in the Status Information.</li> </ul>
<b>Smears constantly appear on the print and noise occurs.</b>	<p><b>Is an obstacle or dirt present on the table rail?</b></p> <ul style="list-style-type: none"> <li>Check on the table rail and clean it.</li> <li>If noise still persists, please contact your local Mutoh dealer.</li> </ul>
<b>The printing position is incorrect (some parts of the media cannot be printed on).</b>	<p><b>Is the media loaded on the correct position?</b></p> <ul style="list-style-type: none"> <li>Go to the Show Edges menu to check the printing area by LED pointer.</li> </ul> <p> <a href="#">"Checking the printing area" P. 49</a></p> <hr/> <p><b>Did the printer start printing from the correct position?</b></p> <ul style="list-style-type: none"> <li>Go to the Show Edges menu to check the print start position by LED pointer.</li> </ul> <p> <a href="#">"Checking the printing area" P. 49</a></p> <p> <b>Note</b></p> <p>To check the printing area before printing, go to <b>**&gt;8: Show Edges" P. 77</b> and select "Step" or "Auto".</p>

Symptom	Possible cause and remedy
<p>Printer doesn't expectedlyprint (ink mottle, ink bleed or faint print appears)</p>	<p><b>Is the media loaded correctly?</b></p> <ul style="list-style-type: none"> <li>• Load the media correctly.</li> </ul> <p> <a href="#">"Loading media" P. 33</a></p>
	<p><b>Are ink cartridges (or ink bags) within the validity period?</b></p> <ul style="list-style-type: none"> <li>• Use a non-expired ink cartridge (or ink bag).</li> </ul>
	<p><b>Did you agitate ink in the cartridge?</b></p> <ul style="list-style-type: none"> <li>• When "Agitate XX Ink" message appears on the operation panel, agitate ink in the cartridge.</li> </ul> <p> <a href="#">"Agitating ink" P. 116</a></p>
	<p><b>Are Nozzles in good condition?</b></p> <ul style="list-style-type: none"> <li>• Perform Nozzle check. Then if nozzle missing is found, conduct head cleaning.</li> </ul> <p> <a href="#">"Nozzle check and cleaning" P. 38</a></p> <ul style="list-style-type: none"> <li>• Perform Daily Maintenance.</li> </ul> <p> <a href="#">"Clean daily maintenance parts" P. 139</a></p> <ul style="list-style-type: none"> <li>• The problem still persists, perform "LittleCharge".</li> </ul> <p> <a href="#">"Maintenance 1: Cleaning" P. 96</a></p>
	<p><b>Is the Ink Maintenance option set to Normal or Light?</b></p> <ul style="list-style-type: none"> <li>• Select the Full mode.</li> </ul> <p> <a href="#">"Advanced Settings 9: Ink Maintenance" P. 86</a></p>
	<p><b>Did you perform Print quality adjustment?</b></p> <ul style="list-style-type: none"> <li>• Perform Print quality adjustment.</li> </ul> <p> <a href="#">"***&gt;2: Adjust Print" P. 66</a></p>
	<p><b>Did you perform layer alignment?</b></p> <ul style="list-style-type: none"> <li>• Perform layer alignment.</li> </ul> <p> <a href="#">"***&gt;3: Adjust Layer Print" P. 68</a></p>
	<p><b>Did you perform Media feed adjustment?</b></p> <ul style="list-style-type: none"> <li>• Perform Media feed adjustment.</li> </ul> <p> <a href="#">"***&gt;4: PF Adjust" P. 72</a></p>
	<p><b>Is the vacuum fan power appropriate for the media being loaded?</b></p> <ul style="list-style-type: none"> <li>• Try lowering the vacuum fan setting. It might improve print quality.</li> </ul> <p> <a href="#">"***&gt;5: Vacuum Fan" P. 75</a></p> <p> <b>Important!</b></p> <p><b>When you lower the vacuum fan setting, make sure that your media does not warp.</b></p>

Symptom	Possible cause and remedy
<p><b>Printed color is not accurate.</b></p>	<p><b>Did you set the settings for print job, media and printer correctly as intended?</b></p> <ul style="list-style-type: none"> <li>• Set these settings correctly.</li> </ul>
	<p><b>Did you agitate ink in the cartridge?</b></p> <ul style="list-style-type: none"> <li>• When "Agitate XX Ink" message appears on the operation panel, agitate ink in the cartridge.</li> </ul> <p> <a href="#">"Agitating ink" P. 116</a></p>
<p><b>Nozzle missing remains afterhead cleaning.</b></p>	<p><b>Are Nozzles in good condition?</b></p> <ul style="list-style-type: none"> <li>• Perform Nozzle check. Then if nozzle missing is found, conduct head cleaning.</li> </ul> <p> <a href="#">"Nozzle check and cleaning" P. 38</a></p> <ul style="list-style-type: none"> <li>• Perform Daily Maintenance.</li> </ul> <p> <a href="#">"Clean daily maintenance parts" P. 139</a></p> <ul style="list-style-type: none"> <li>• the problem still persists, perform "LittleCharge".</li> </ul> <p> <a href="#">"Maintenance 1: Cleaning" P. 96</a></p>
	<p><b>Is the Ink Maintenance option set to Normal or Light?</b></p> <ul style="list-style-type: none"> <li>• Select the Full mode.</li> </ul> <p> <a href="#">"Advanced Settings 9: Ink Maintenance" P. 86</a></p> <hr/> <p><b>Is there any ink stains or deposits on the cleaning wiper or circumference of the print head?</b></p> <ul style="list-style-type: none"> <li>• Perform head cleaning or "Little Charge" again and check the nozzle check print.</li> </ul> <p> <a href="#">"Nozzle check and cleaning" P. 38</a></p> <ul style="list-style-type: none"> <li>• Perform Daily Maintenance and check the nozzle check print.</li> </ul> <p> <a href="#">"Clean daily maintenance parts" P. 139</a>, <a href="#">"Nozzle check and cleaning" P. 38</a></p> <ul style="list-style-type: none"> <li>• The problem still persists, contact your local Mutoh dealer.</li> </ul> <p> <b>Important!</b></p> <p><b>Do not use media that are liable to reflect the UV light. The reflective UV light can cure the ink on the print head.</b></p>

# Specifications of this product

## List of specifications

Model Name	XPJ-661UF	
Print method	On demand piezo method	
Drive method	Firmware servo/DC motor drive	
Media feed method	Setting on (removing from) the table from the front, with the front cover open	
Media hold down method	Vacuum Table	
Ink curing device	UV-LED Lamp	
Conditions of usable media	Maximum width	483 mm
	Maximum length	594 mm
	Maximum thickness	150 mm
	Weight	up to 6 kg (including jig)
Maximum print width	483 mm	
Maximum print length	594 mm	
Head height adjustment	Automatic table height control by the obstacle sensor (manual adjustment is also available)	
CPU	64bit RISC CPU	
Memory	256MB	
Interface	Ethernet (10/100BASE-TX)	
Ink	Color	4 colors (Black, Cyan, Magenta, Yellow) 6 colors (Black, Cyan, Magenta, Yellow, White, Varnish)
	Type	220 ml ink cartridge, 800 ml ink bag (500 ml ink bag for White ink)
Waste Ink Tank	Fixed to the body type, capacity 2,000 ml, waste ink discharge by users	

Environmental conditions	Operation environment	Temperature 20 to 32 °C, humidity 40 to 60%, no condensation.
	Recommended Printing Environment	Temperature 22 to 30 °C, humidity 40 to 60%, no condensation.
	Change rate	Temperature: No more than 2 °C per 1 hour Humidity: No more than 5% per 1 hour
	Environment for storage	Storage without ink charging: up to 6 months Temperature -20 to +60 °C, humidity 20 to 80% Storage with ink charging: up to 30 days <sup>*1</sup> <sup>*2</sup> Temperature 5 to +30 °C, humidity 20 to 80% <sup>*1</sup> Perform the <b>"Daily Maintenance" P. 128</b> in the operation manual. <sup>*2</sup> Always leave the printer in sleep mode and check the remaining ink level once a week. Agitate the ink once a week as instructed.
	Ink Storage Environment	<ul style="list-style-type: none"> <li>· UH21 ink Black/Cyan/Magenta/Yellow/Varnish (220 ml or 800 ml) White (220 ml or 500 ml) Temperature -10 to 50 °C (The storage period between 40 °C and 50 °C should be up to one month) Humidity: 5 to 85%, No condensation</li> <li>· US11 ink Black/Cyan/Magenta/Yellow/Varnish (220 ml or 800 ml) White (220 ml or 500 ml) Temperature 5 to 35 °C Humidity: No condensation</li> <li>· Cleaning cartridge (220 ml) (both UH21 and US11 inks) Temperature -10 to 50 °C (The storage period between 40 °C and 50 °C should be up to one month) Humidity: 5 to 85%, No condensation</li> </ul>
Power supply specifications	Voltage	AC 100 V to 240 V ±10%
	Frequency	50/ 60Hz ±1Hz
	Capacity	No less than 3.5 A
Power consumption	Power off	AC 100 V to 120 V, 2.1 W or below AC 200 V to 240 V, 3.2 W or below
	Sleep mode	20 W or below
	Standby mode	40 W or below
	Operation	300 W or below
Current consumption	100 V to 120 V	3.5 A or below
	200 V to 240 V	1.8 A or below
External dimensions	Height	604 mm (with stand: 1,254 mm)
	Width	1,188 mm
	Depth	1,627 mm
Weight	Main body	130 kg
	Stand (option)	21 kg



## Options / Supply list

For more information about the options and the supply items, contact your local MUTOH dealer.

## Revision History

Date	Version	Manual code	Supported Firmware
2019. 12	00	XPJ661UFE-A-00	V.1.00
2021. 2	01	XPJ661UFE-A-01	V.1.01
2021. 5	02	XPJ661UFE-A-02	V.1.01
2022. 1	03	XPJ661UFE-A-03	V.1.04
2022. 2	04	XPJ661UFE-A-04	V.1.05
2022. 6	05	XPJ661UFE-A-05	V.1.06 or later

**MUTOH**