

MUTOH

XPJ-C641SR-P

Startup Guide

Unpacking and Assembling Instructions

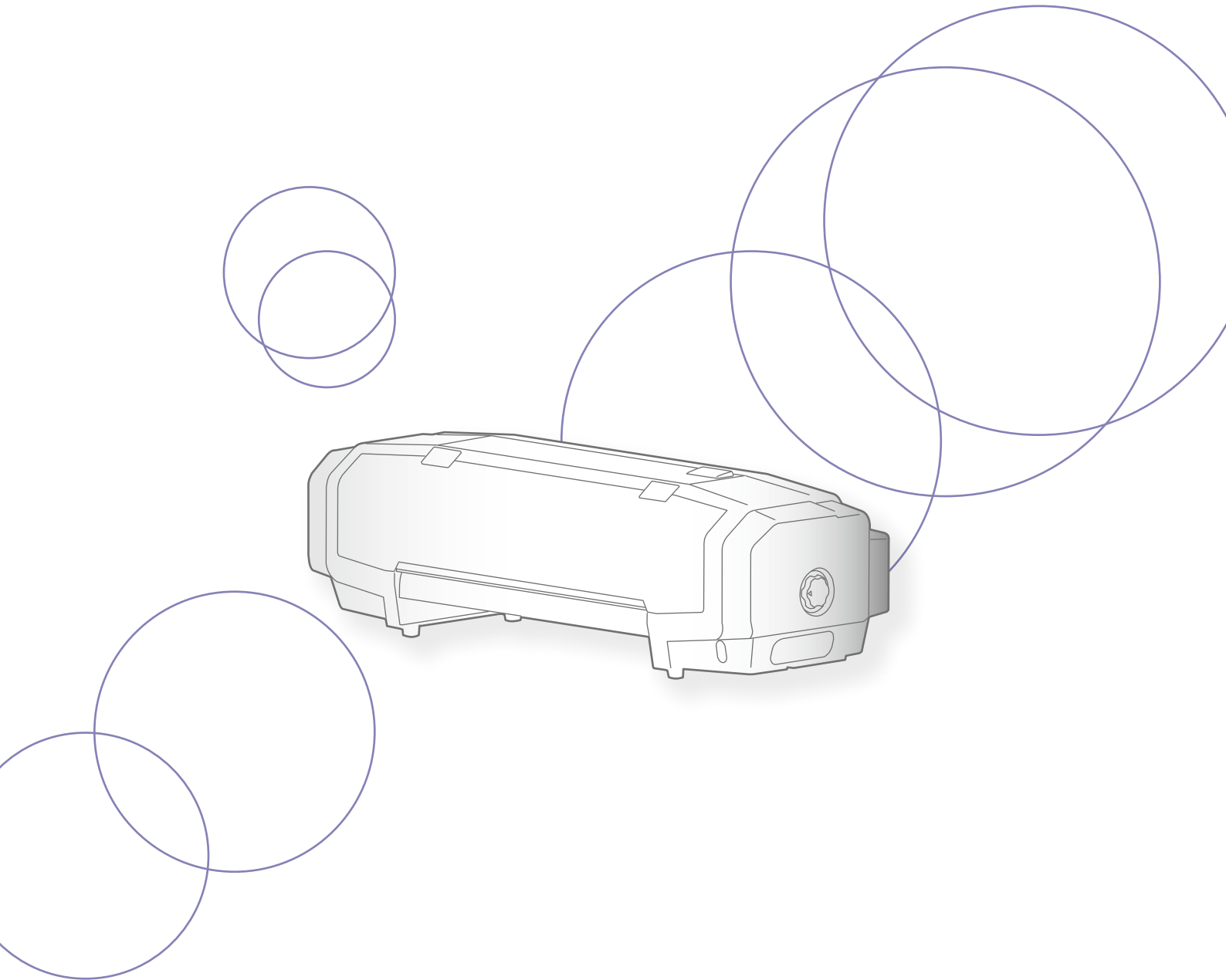

Important Notice

For Users in Europe

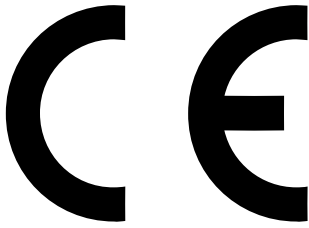

The CE marking is a mandatory European marking for certain product groups to indicate conformity with the essential health and safety requirements set out in European Directives.

By affixing the CE marking, the manufacturer, his authorized representative, or the person placing the product on the market or putting it into service ensures that the item meets all the essential requirements of all applicable EU directives and that the applicable conformity assessment procedures have been applied.

For Users in the United States

This equipment has been tested and found to comply with the limits for a Class A digital device, pursuant to Part 15 of the FCC Rules. These limits are designed to provide reasonable protection against harmful interference when the equipment is operated in a commercial environment. This equipment generates, uses, and can radiate radio frequency energy and, if not installed and used in accordance with the instruction manual, may cause harmful interference to radio communications.

Operation of this equipment in a residential area is likely to cause harmful interference in which case the user will be required to correct the interference at his own expense.

CAUTION

Use of controls or adjustments or performance of procedures other than those specified herein may result in radiation exposure.

Microsoft® and Windows® are either registered trademarks or trademarks of Microsoft Corporation in the United States and/or other countries.

VerteLith™ is trademark of MUTOH INDUSTRIES LTD.

Company names and product names that appear in this Guide are registered trademarks or trademarks of the respective companies.

- Unauthorized copying or duplication of the whole or part of the contents of this Guide is prohibited.
- Every care has been taken in writing the contents of this Guide, but please contact MUTOH or the dealer you purchased the product from if you find any unclear, erroneous or otherwise unsatisfactory content in the Guide.
- Please be aware that MUTOH will not be liable in any way for failures or accidents that result from handling or operating the printer according to any procedures other than those set forth in this Guide.

Safety Precautions **5**

Safety Symbols.....	5
Electrical shock/ short circuit/ fire hazards.....	6
Installation.....	7
Handling	8
Ink and waste fluid.....	9
Warning labels.....	10
Instruction Labels	11

Check before installation **12**

Installation Location Requirements.....	12
Minimum Space Requirements	12
Power Specification	13
Environmental Requirements.....	13

Unpacking **14**

Preparations.....	14
Unpacking the machine.....	15
Unpacking the optional stand	17

Assembling **18**

Assembling the main unit and the optional stand.....	18
Removing protective materials	22

Preparations

24

Connecting the power cord and Ethernet cable	24
Turning on the print and cut machine	27
Downloading software	28

Setup



30

Setup Flow	30
Configure initial setup of VerteLith and machine	31



Safety Precautions

Safety Symbols



■ The following classifications indicate hazards or damage that could result from ignoring instructions or incorrect handling.

 Warning	Failure to follow the instructions could result in serious injury or death.
 Caution	Failure to follow the instructions could result in minor injury or damage to the whole or part of the product.

■ The following symbols indicate precautions that must be followed.

	An action that must be avoided.
	An important instruction that must be followed.

■ Other symbols

 Important!	Provides information that require special attention or should be followed.
 Note	Provides supplemental or reference information.
	Indicates the link to the reference section.

 **Note**

For the name of each part marked with warning or caution symbols, see “Before Use” on the XPJ-C641SR-P operation manual.

Check before installation

Unpacking

















Assembling

Preparations

Setup

Electrical shock/ short circuit/ fire hazards

Warning

	<p>Do not install this product in a location with high humidity and dust. This could result in an electrical shock or fire.</p>		<p>Make sure to use a designated power socket. Failure to do so could result in an electrical shock or fire.</p>
	<p>Do not use a damaged power cord. This could result in an electrical shock or fire.</p>		<p>Plug the power cord into the wall outlet. Do not use power strips. This could generate heat, resulting in fire.</p>
	<p>Do not connect or disconnect the power plug with wet hands. This could result in an electrical shock.</p>		<p>Plug the power cords into the wall outlet that has the earth connection and make sure to connect the earth. If the earth is not connected, an electrical shock or fire may occur.</p>
	<p>Do not connect an earth wire to the following places:</p> <ul style="list-style-type: none"> • Gas pipe It has potential risks of fire or explosion. • Earth wire of telephone cables or lighting rods Large current may flow when the lightning strikes. • Water pipe or faucet It may not work properly if a plastic pipe is connected to the pipe. 		<p>Make sure to connect an earth wire to the earth connection that meets the following requirements:</p> <ul style="list-style-type: none"> • Earth terminal of power socket. • An earth wire with a copper plate which is buried at 650 mm or more in the ground.
			<p>Keep ink away from fire or heat source and store in a cool, dark place.</p>
	<p>Do not insert or drop metal or flammable objects into the printer through openings such as vent. This could result in an electrical shock or fire.</p>		<p>Be sure to use the designated power cords.</p> <ul style="list-style-type: none"> • Failure to do so could result in an electrical shock or fire. For the designated power cord, please contact your local MUTOH dealer.
	<p>Do not block the vent on the product with cloth or other materials. If covered, the inside the product gets hot, resulting in fire.</p>		<ul style="list-style-type: none"> • The power cord should have the protective ground terminal and make sure to plug in securely.
	<p>Never open the covers securing with screws. This could result in an electrical shock or damage to the printer.</p>		<ul style="list-style-type: none"> • Use the power cords which meet the safety standard, voltage and plug shape of the country to use this product.
	<p>Ensure that no moisture enters the product. This could result in an electrical short circuit.</p>		<p>Make sure to follow the instructions on this guide to connect the power cord or cables. Failure to do so could result in fire.</p>
	<p>If foreign objects or liquid accidentally entered the inside of the printer, do not use it. This could result in an electrical shock or fire. Immediately power off the printer and disconnect the power plug from the outlet. Then contact the MUTOH customer support.</p>		



Check before installation

Unpacking

Assembling

Preparations





Setup

	<p>Follow the precautions below when handling the power cord.</p> <ul style="list-style-type: none"> • Do not modify power cords. • Do not place heavy objects on power cords. • Do not bend, twist, or pull on power cords. • Do not route power cords near heating equipment. 		<p>Follow the precautions below when handling the power plug.</p> <ul style="list-style-type: none"> • Do not allow dust or foreign objects to accumulate around the power plug. • Firmly insert the power plug into the wall outlet. <p>Incorrect handling could result in fire.</p>
---	---	---	---

Check before installation

Installation

Warning



	<p>Choose the location which satisfies the requirements below:</p> <ul style="list-style-type: none"> • The floor must be level. • Avoid vibration from the neighboring devices. • Low humidity and free from dust. • Less chance of temperature and humidity changes. • Avoid direct sunlight. • Avoid water. • Avoid direct air onto the printer. • Low levels of electromagnetic waves. 		<p>Install the product in a location where ventilation can be carried out.</p> <p>Keep the work area well-ventilated.</p> <p>Odor of the ink could have adversely impact on health.</p> <p>If you experience headache, fatigue or dizziness, stop your work and immediately get to fresh air.</p> <p>If nausea persists, seek medical advice.</p>
			<p>This equipment is not suitable for use in locations where children are likely to be present.</p>
	<p>Before taking out the product from the packaging box, make sure to remove the plastic sheet wrapped around the product first.</p> <p>Failure to do so could cause slip or damage to the product.</p>		

Unpacking

Assembling

Preparations



Caution

	<p>At least two people are required for moving this product. When moving, keep the product level.</p>		<p>Do not tilt the product.</p> <p>The ink inside the product may spill. MUTOH cannot guarantee that the printer can run properly.</p>
---	---	---	---











Setup

Handling

Warning



	Do not sit on or place heavy objects on the product. Failure to do so could result in injury from a fall.
	Do not touch the moving parts. This could cause injury or damage to the product.
	In case you need to move the product after ink was filled, move it slowly to avoid impact and risk of ink leakage.

Caution





	Never touch the print head nozzles when cleaning the parts around the print head. This could damage the print head.		Do not touch the cleaning wiper and the print head cap unit with bare hands when cleaning the wiper. If finger oil gets on this, head cleaning cannot be performed properly.
	Do not use the media fixing handle while in printer initialization or printing. The print head can interfere with the pressure rollers and cause damage.		Do not touch the media feed slot, platen and media guide while the heater is in operation. These parts get hot and could cause burn injury.
	Do not use volatile chemicals such as thinner, benzine or alcohol for cleaning. This will damage the paint on the printer.		Do not touch the media guide while printing. The media guide becomes hot and you could get burn injuries.
	Do not push the tab on the cutter holder too hard or release suddenly. There is a spring under the cutter so that the cutter may jump out from the holder.		Do not touch the blade edge. This will cause injury.
	Do not attempt the following actions during ink charging: <ul style="list-style-type: none"> • Power off the printer. • Disconnect the power cord. • Open the front cover or the maintenance cover. • Put the media fixing handle in unlock position. 		Immediately after printing, the media guide gets hot. Allow it to cool down enough to do the work.
	Before moving this printer, always empty the waste ink tank even moving short distance. Failure to do so may result in damage to the product.		

Ink and waste fluid

Warning

	Make sure to read the Safety Data Sheet (SDS) before using ink cartridges for the first time.
	Store ink cartridges and waste fluids in a cool, dark place and avoid direct sunlight. Keep away from <ul style="list-style-type: none"> • children's reach • fire and heat
	When disposing of ink, waste fluid collected from the printer, or containers and paper towels with ink adhered, be sure to follow the instructions of industrial waste disposal contractors, related laws, and local regulations to dispose of them.

Caution

	Follow these precautions when handling ink cartridge: <ul style="list-style-type: none"> • Do not disassemble • Do not drop or hit This could lead to ink leakage.		Use MUTOH genuine ink. This printer is designed to deliver best performance by using MUTOH genuine ink. The use of non-genuine ink may affect the printer as well as print quality. This is not covered by the warranty.
	Use inks within its shelf life. <ul style="list-style-type: none"> • Using an expired ink could result in damage to the printer. • When expired, replace with a new one even if ink remains in the ink bag. • Dispose of expired ink as industrial waste. Put the emptied ink cartridge in a plastic bag and dispose of it according to the local regulations. 		
	When handling ink cartridges, avoid skin or eye contact with ink. If in eyes or on skin, immediately flush with running water. If left untreated, it could cause bloodshot eyes or mild inflammation. If there is any abnormality, seek medical advice immediately.		

Check before installation

Unpacking

Assembling

Preparations

Setup

Warning labels

Warning labels are affixed to the hazardous area of the product. Read and follow the instructions on the labels.

In case the warning labels came off or get dirty, please contact your local MUTOH dealer for replacement.

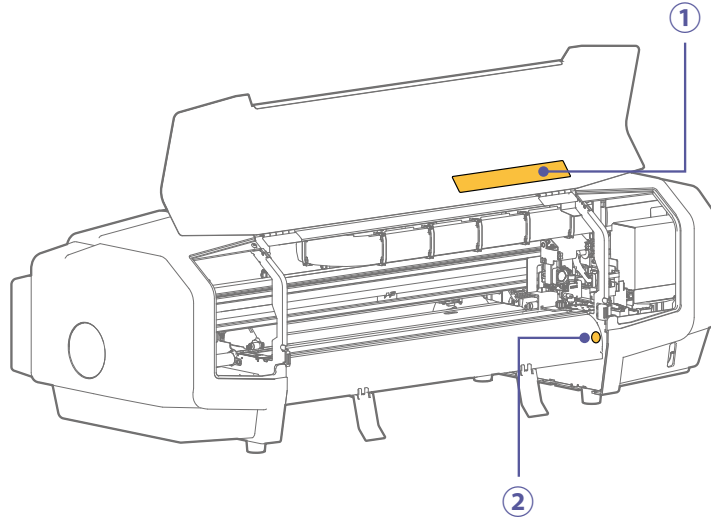

	Type of labels	Name / Meaning
①		<p>Cut Hazard Label for Cutter</p> <ul style="list-style-type: none"> Do not insert your fingers around the cutter. The cutting blade may injure your fingers.
②		<p>Do Not Put Hand Label</p> <ul style="list-style-type: none"> Contacting with carriage could cause injuries.

Check before installation
Unpacking
Assembling
Preparations
Setup

Instruction Labels

Instruction labels are affixed where special attention for operating this product is required. The contents of each label are shown here.

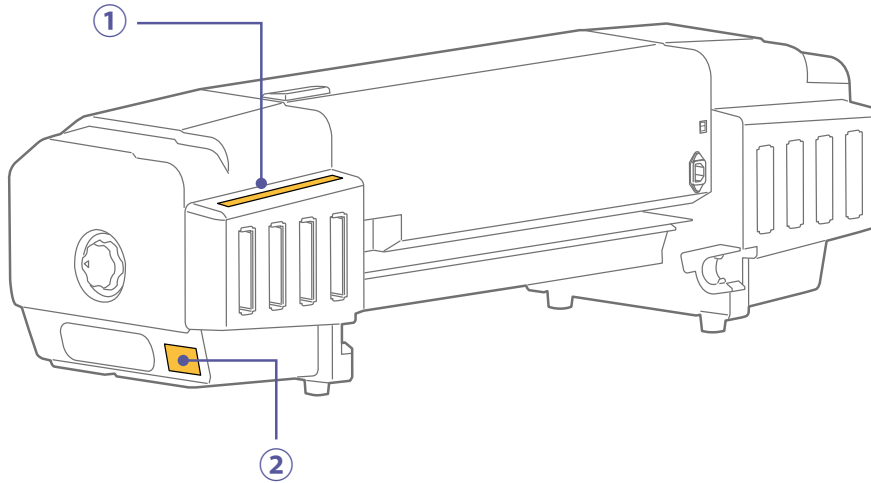

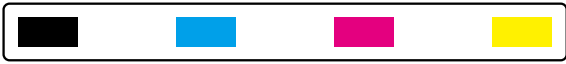
Type of labels	Name / Meaning
<p>①</p> 	<p>Ink Color Label</p> <ul style="list-style-type: none"> • Insert the correct color of ink cartridge according to this label.
<p>②</p> <div style="border: 1px solid black; padding: 5px; width: fit-content;"> <p>◆When moving this product, always empty the waste ink tank. If ink splashes inside the waste ink tank while being moved, it can cause damage.</p> <hr/> <p>◆本製品を移動するときは、廃液タンクを空にして下さい。移動時に廃液タンク内でインクがはねると故障の原因となります。</p> </div>	<p>Moving Instruction Label</p>

Check before installation

Unpacking

Assembling

Preparations

Setup

Check before installation

Installation Location Requirements

Choose the location which satisfies the requirements below.

- The floor must be level
- Avoid vibration from the neighboring devices
- Low humidity and free from dust
- Less chance of temperature and humidity changes
- Avoid direct sunlight
- Avoid water
- Avoid direct air onto the product (including air from air conditioner)
- Low levels of electromagnetic waves



Caution

- This product is not suitable for use in location where children are likely to be present. Keep the work area well-ventilated. Odor of ink may adversely impact on health. If you experience headache, fatigue or dizziness, stop your work and immediately get to fresh air. If nausea persists, seek medical advice.

Minimum Space Requirements

The following space is required for installation.

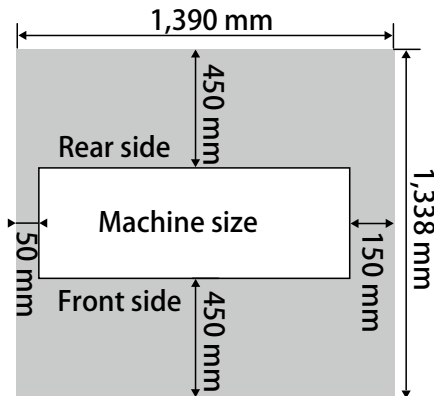

Machine size

Width x Depth: 1,190 mm x 438 mm

Height (with cover opened):

573 mm

with stand attached 1,373 mm

Power Specification

The installation site must meet the following power specification:

- **Input voltage :**
AC 100V to 120V \pm 10%
AC 200V to 240V \pm 10%
- **Input frequency :**
50/60 Hz \pm 1Hz
- **Input load current :**
6.5 A or more

Environmental Requirements

The installation site must meet the following environmental requirements:

- **Operating condition:**
Temperature: 20° C to 32° C
Humidity: 40% to 60%, non condensing
- **Printing Condition:**
Temperature: 22° C to 30° C
Humidity: 40% to 60%, non condensing
- **Machine Storage Condition:**
Without ink filled : Within 6 months : Temperature: -20° C to 60° C
Humidity: 20% to 80% (non condensing)
With ink filled : Within 1 week (*)
*Storage must be within 4 days when stored at 32° C or over
Temperature: -10° C to 40° C
Humidity: 20% to 80% (non condensing)

Check before
installation

Unpacking

Assembling

Preparations

Setup

Unpacking

Preparations

Please check the points below before unpacking.

- At least two people are required for unpacking, assembling and installing this product.
- You will need the following items other than the supplied items for installation.



□ Computer : 1

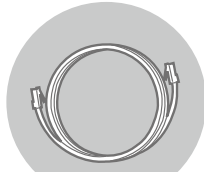

□ Ethernet cable : 2

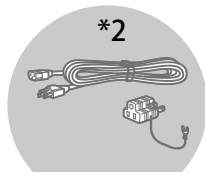

□ Power cord : 1

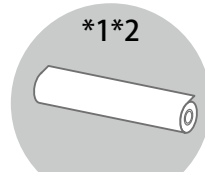

□ Media : 1

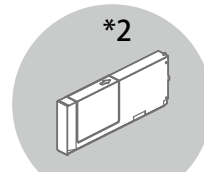

□ Cleaning cartridge : 4

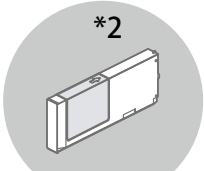

□ Ink cartridge : 4

Or

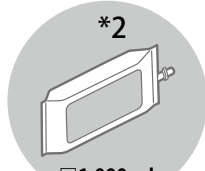

□ 1,000 ml Ink bag : 4

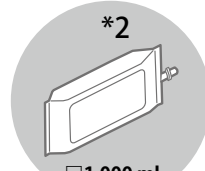

□ 1,000 ml Cleaning bag : 4

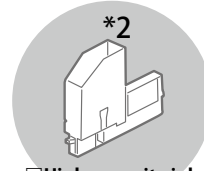

□ High-capacity ink pack adapter : 4

*1 Usable size of media

- 2-inch or 3-inch paper core
- Outer diameter: Up to 150 mm
- Media width: 198 mm to 630 mm
- Weight: Up to 9 kg

*2 Optional accessories or consumable supplies



Warning

Make sure to use the designated power cord.
Failure to do so could cause electric shock or fire.



Important !

Make sure your computer meets the following requirements:

- OS: Windows 11, Windows 10
- CPU: Intel (R) Core (TM) i5 or more
- Memory: 16 GB minimum
- Network: Ethernet network port



Note

- The OS support period of software supplied from MUTOH conforms to the Microsoft support lifecycle policies.
- Please also check the system requirements of your RIP software.

Unpacking the machine

Caution

- At least two people are required for unpacking and moving this machine.
- When taking out the machine from the packaging box, remove the plastic sheet wrapped around the machine, then take it out. Failure to do so may cause slip and damage to the machine.
- Keep the machine level while moving.

Follow these steps to unpack this product.

1 Open the packaging box and take out each part.

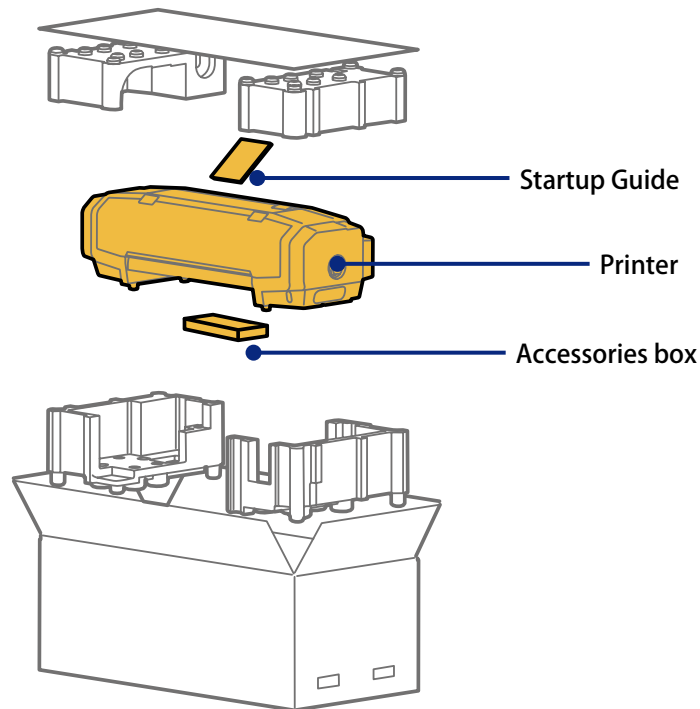

Note

When moving this product, hold the following parts of the product.

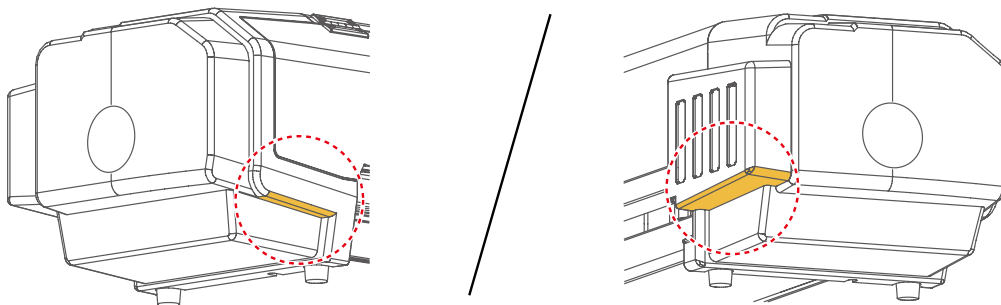

2 Check that the following items are included.

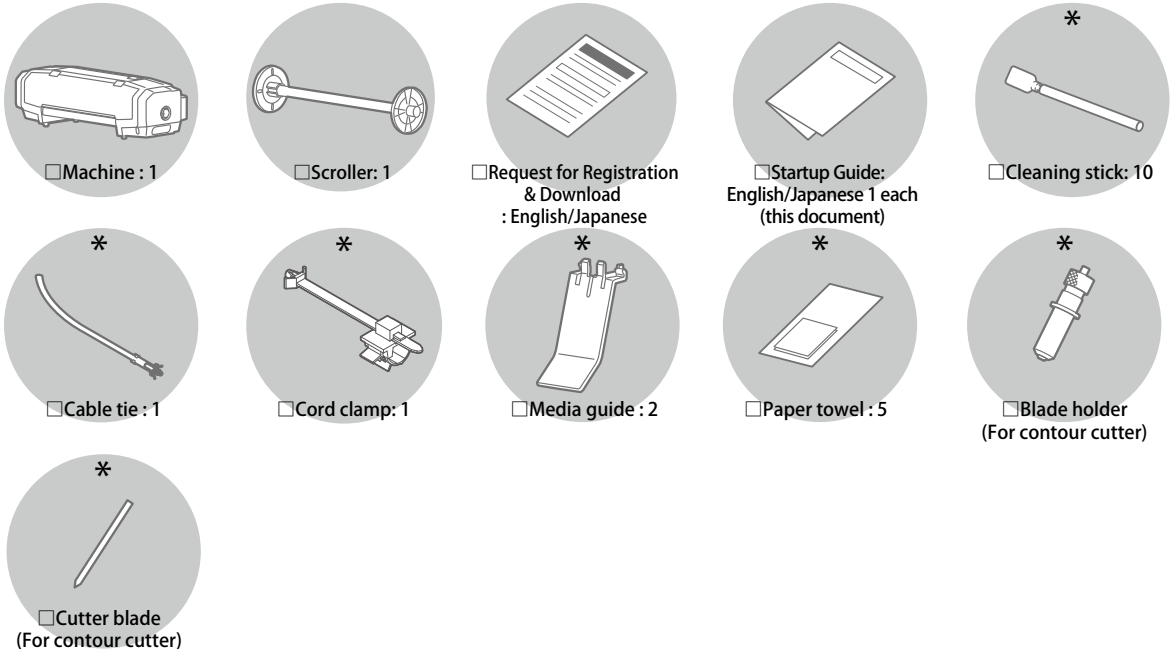

Important !

- The items with asterisk mark in the above illustration are included in the accessories box.
- A cutter blade is installed in the blade holder.

Check before installation

Unpacking

Assembling

Preparations

Setup

Unpacking the optional stand

1 Open the packaging box and take out each part.

2 Check that the following items are included.

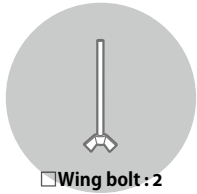
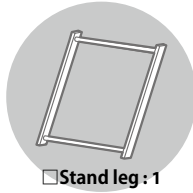
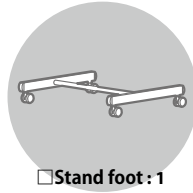
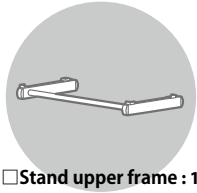

※ For the stand with reinforcement, the following items are also included.

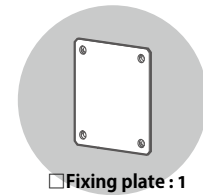
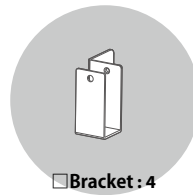
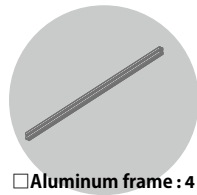

Assembling

Assembling the main unit and the optional stand

1. Attaching media guides and cable ties

Follow these steps to attach the media guides and the cable ties.

- 1 Attach the media guides.

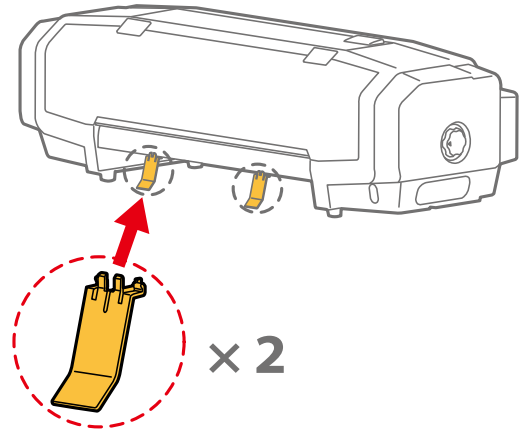

- 2 Attach the supplied cable ties to the position shown in the illustration on the rear side of the machine.

Note

- These ties are used for securing the cables so that they do not interfere with a roll media.
- Cable ties can be loosen or unbound by pushing the nail near the insertion hole.

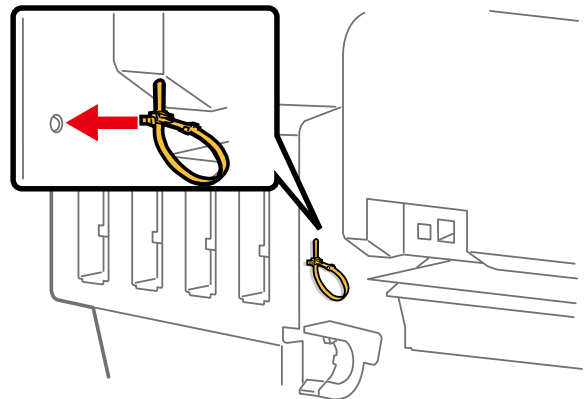

- 3 Attach the supplied cord clamp to the position shown in the illustration on the rear side of the machine.

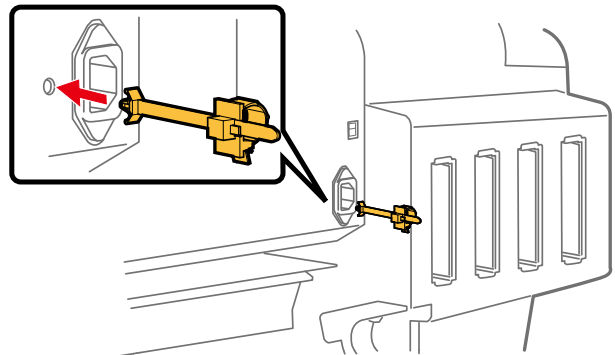

2. Assembling the optional stand

Check before installation

Unpacking

Assembling

Preparations

Setup

Caution

At least two people are required for mounting the machine on the stand.

Follow these steps.

1 Assemble the stand.

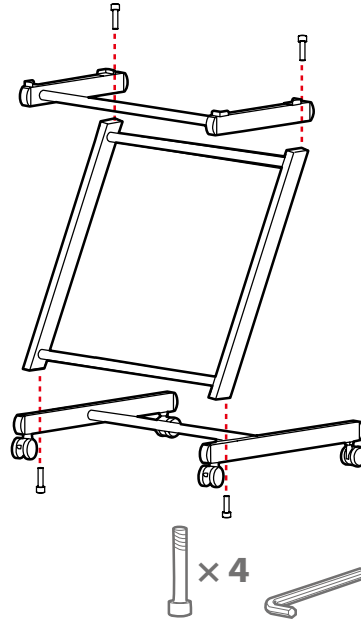

2 Lock the casters.

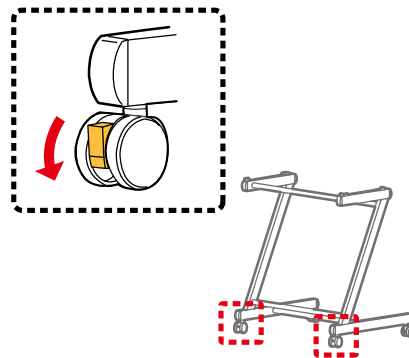

3 • Adjust the position of the rubber feet and place the machine on the stand.
• Fasten with wing bolts.

Note

If your stand includes the reinforcement, move to the next step.

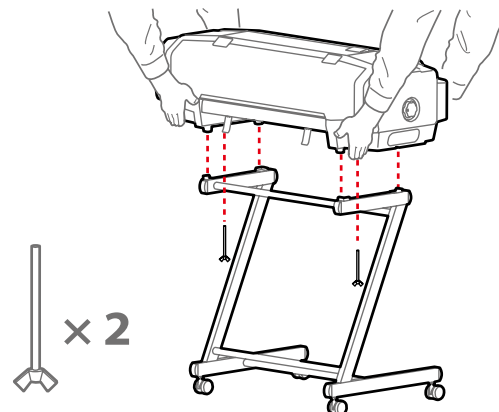

Stand with reinforcement

Next follow these steps to assemble the stand.

- 1 Use the screws to temporarily attach the bracket to the stand frame.

- Screw (M5x40) × 4

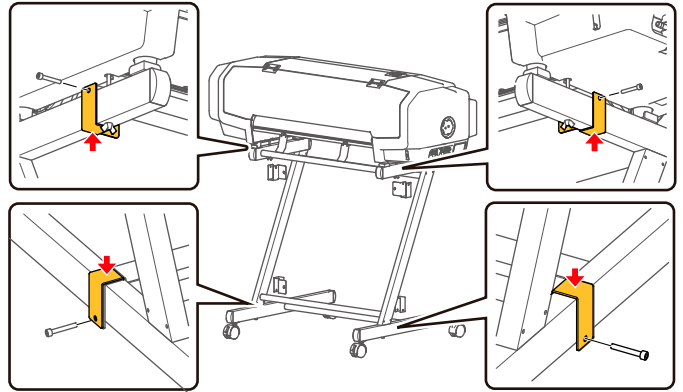

- 2 Move the bracket to the position shown in the illustration.

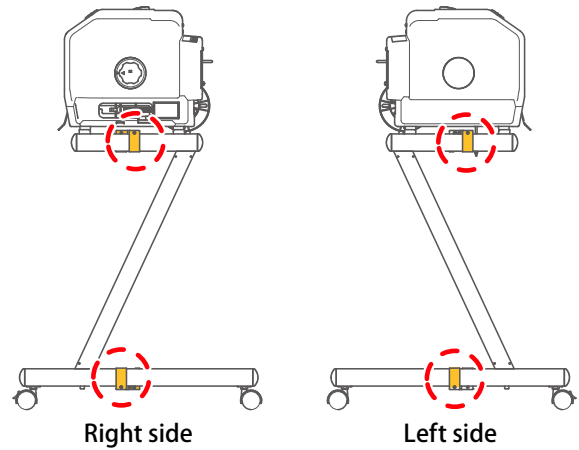

Right side

Left side

- 3 Use the screws to temporarily attach the aluminum frame to the bracket.

- Screw (M5x10) × 4

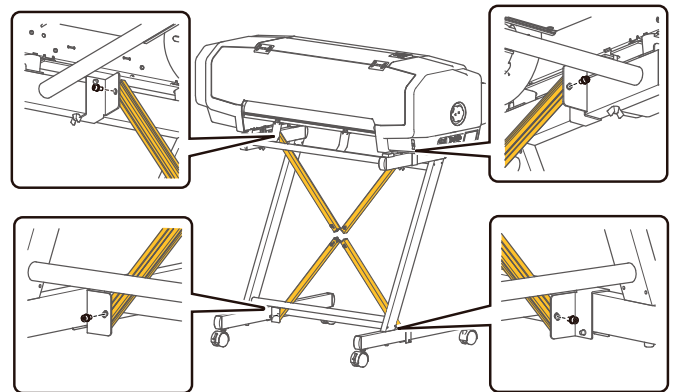

Check before installation

Unpacking

Assembling

Preparations

Setup

- 4 Use the screws to attach the fixing plate to the center of the four aluminum frames.

- Screw (M5x10) × 4

 **Note**

When attaching the fixing plate, the side with large chamfered corner should be upper side.

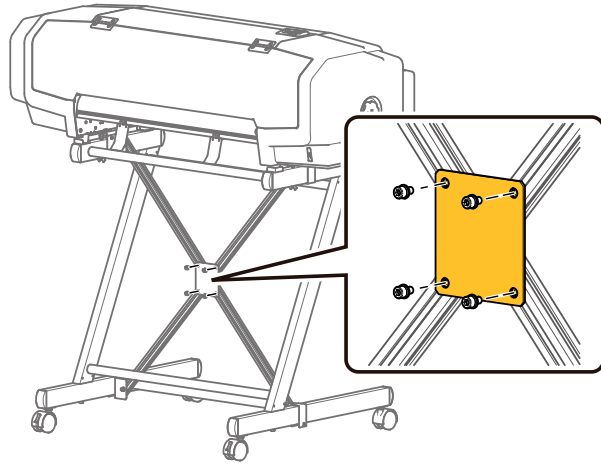

- 5 Tighten all the screws that were temporarily attached.

Check before
installation

Unpacking

Assembling

Preparations

Setup

Removing protective materials

Follow these steps.

1 Remove all the protective materials and tapes attached to the outer side of the machine.

2 Open the front cover.

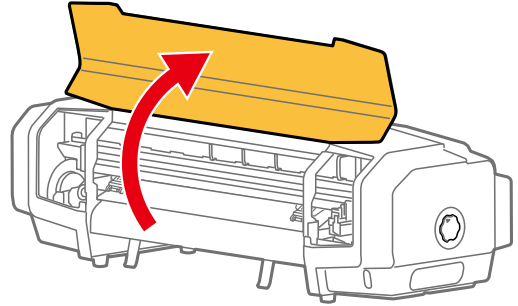

3 Remove the roller protection sheet.

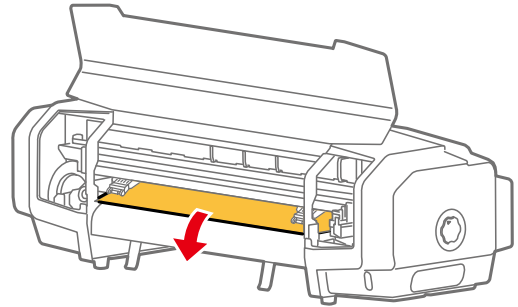

4 Remove the tape and remove the steel veyor protector.

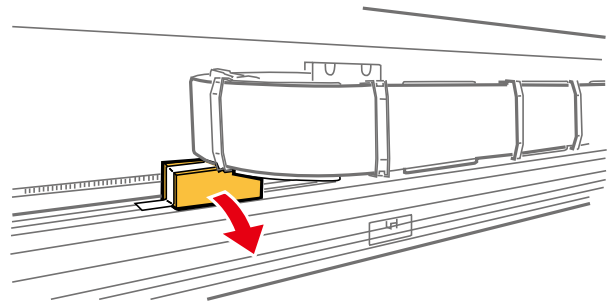

5 Remove the tape and move the edge holders to the left and right ends.

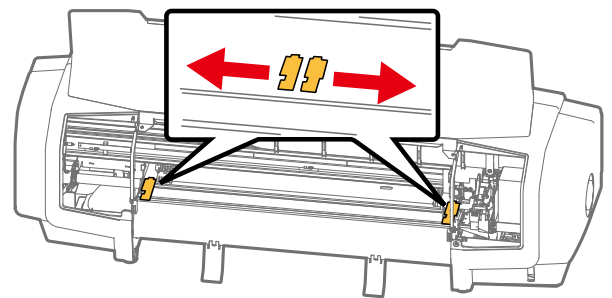

6 Remove the tape securing the sheet cutter.

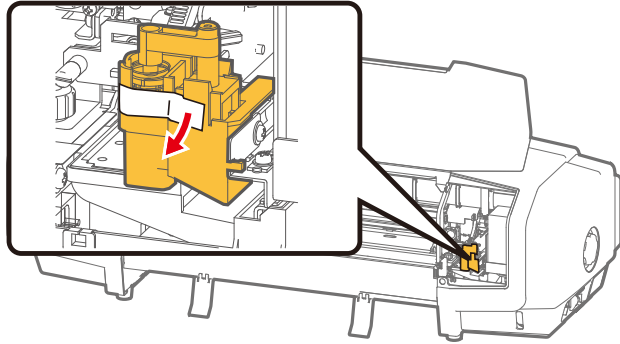

7 Remove the tape securing the contour cutter.

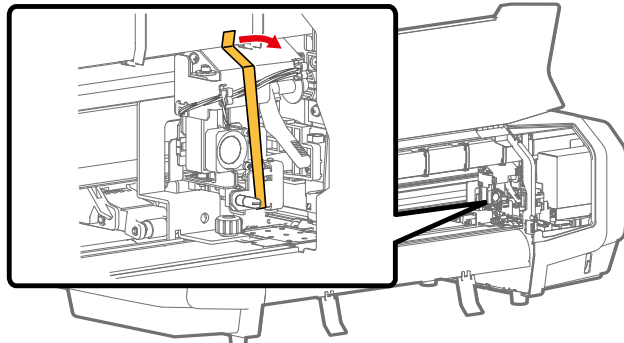

8

- Remove the screw and remove the carriage shipping bracket.
- Close the front cover.

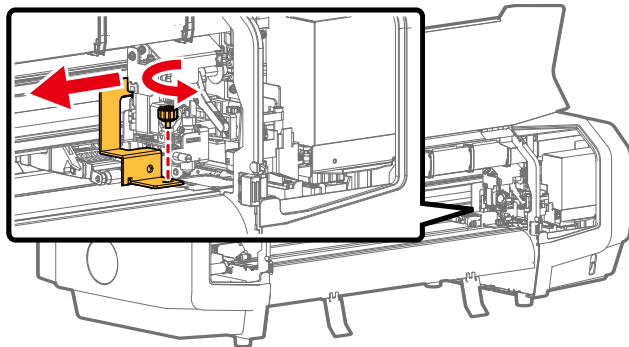

Important!

Keep the following parts for reuse. You will need them when transporting this machine.

- Roller protection sheet, Steel veyor protector, Carriage shipping bracket and screw

Check before
Installation

Unpacking

Assembling

Preparations

Setup

Preparations

Connecting the power cord and Ethernet cable

1. Before connecting the cable

- Turn the media fixing handle to lock it.
 - Check that the knob of the drain tube valve is in the position shown in the illustration.

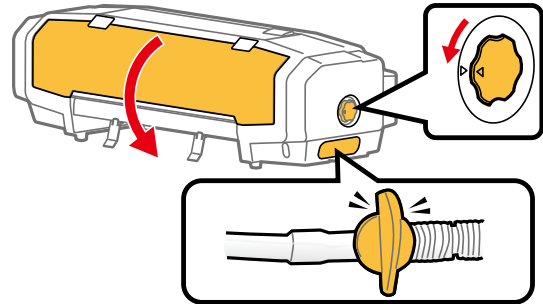

2. Connecting the power cord

- Check that the power button is OFF.

Note

When it is ON, the power button is pressed in. Press the button again to turn it off.

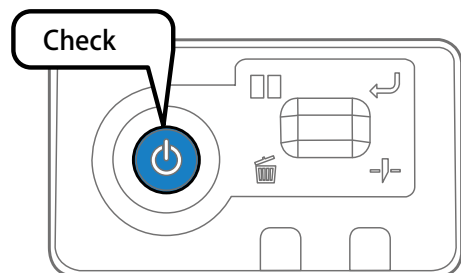

- Set the voltage switch appropriately depending on the voltage of the country you are using this machine.

Note

Voltage switch

- 115V: AC100V - 120V region
- 230V: AC200V - 240V region

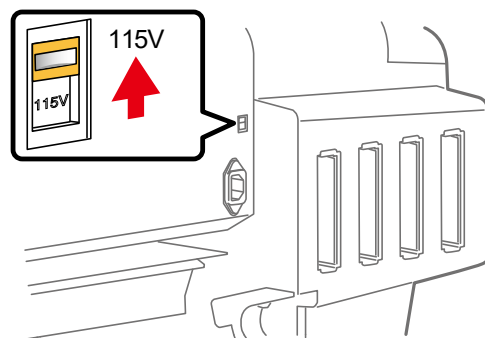

Note

- By factory default, the voltage switch is set to 230V.
- If the voltage switch does not match the local voltage, an error will occur. For errors, see "Troubleshooting" in the operation manual.

3 Connect the power cord to the machine.

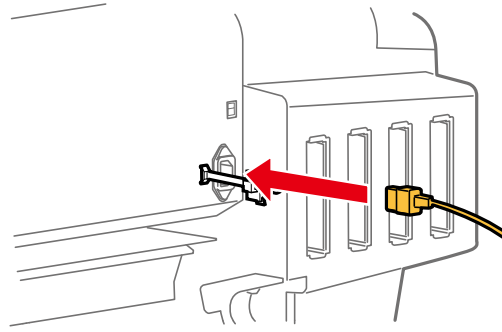

4 Secure the power cord to the cord clamp.

1. Pass the power cord through the clamp and push in to close the cord clamp until it clicks.
2. Slide the clamp to the inlet direction.

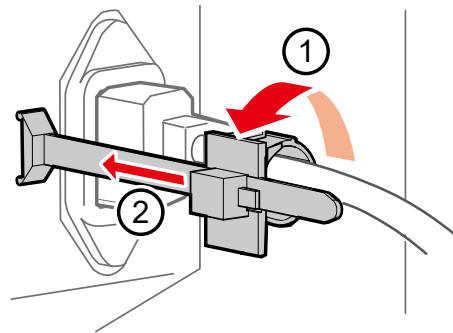

5 Plug the power cord correctly into the wall outlet.



Warning

Do not use power strips.

3-pin plug

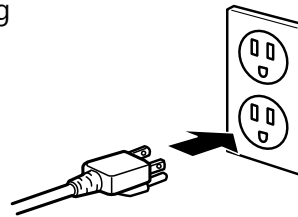

Check before installation

Unpacking

Assembling

Preparations

Setup

3. Connecting an Ethernet cable

1 Connect the Ethernet cable to this product.

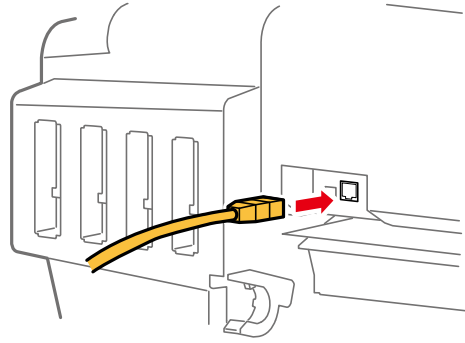

2 Secure the Ethernet cable with the cable tie.

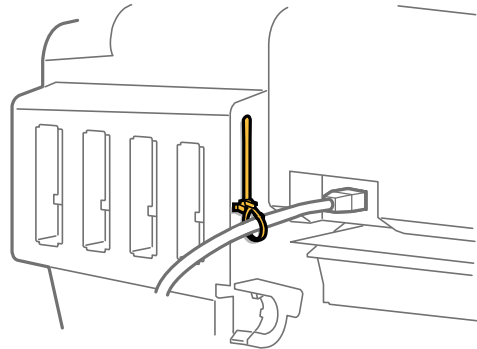

3 Connect the Ethernet cable to the LAN port of the networking device like hub or router.

Important!

This product should be used in a LAN environment with Internet access.

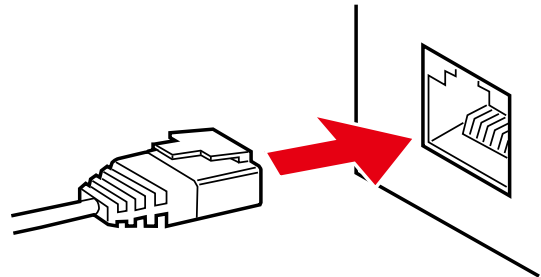

4 Use the other Ethernet cable to connect the computer to the networking device.

Important!

Make sure that your machine and your computer are on the same subnet.

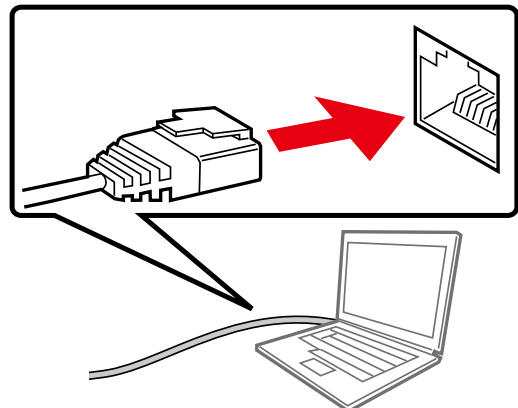

Turning on the print and cut machine

1 Press the power button on this machine.

- The blue lamp on the panel will light up.
- Machine initialization begins.

Important!

Before turning on this machine, make sure that

- the media fixing handle is locked.
- the front cover is closed.

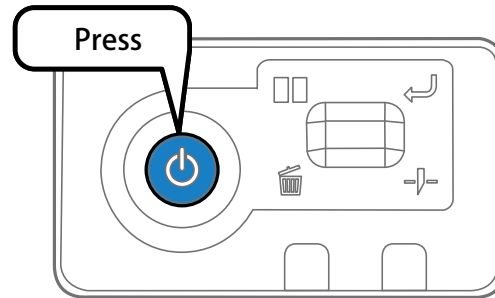

2 Turn on the computer.

Downloading software

You will install the following software in the computer that connects to this machine.

The software and manuals can be downloaded from MUTOH Club.

	<p>MUTOH Status Monitor (MSM) You can check the machine status information, change various settings and perform test printing.</p>
<p>All-in-one Installer</p>	<p>Manual (Printer and software)</p> <p>The following manuals are included</p> <ul style="list-style-type: none"> • XPJ-C641SR-P Operation Manual “Operations and Maintenance Methods” • XPJ-C641SR-P Startup Guide (this manual) • MUTOH Status Monitor User’s Manual • VerteLith User Manual
<p>VerteLith</p>	<p>This genuine RIP software maximizes the performance of MUTOH printers and streamlines your workflow. (License purchase required)</p>

MUTOH Status Monitor (MSM) must be installed before printing. Once installed, follow the MSM operation manual to do initial setup and machine registration.

 MUTOH Status Monitor OPERATION MANUAL 「Initial Setting」

Important !

Make sure to use MSM downloaded from MUTOH Club.

1 Access MUTOH Club (<https://mutoh-club.com/>).

2 Click [Login].

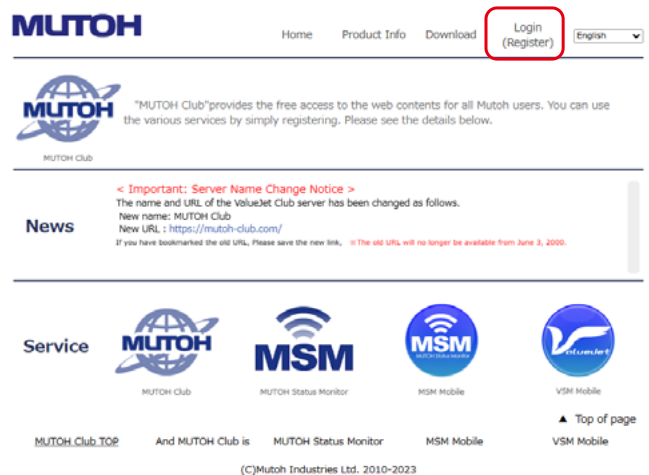

- 3 On the next screen, click [New Registration] and follow the on-screen instruction to complete user registration. Once completed, go to the download page.

 **Important !**

The activation code displayed during registration is required the first time you start this machine.
(It will also be sent to your registered email address)

- 4 Download the zip file for this product.

 **Note**

For the download and installation methods of VerteLith, see the VerteLith Installation Guide supplied with VerteLith.

Setup

Setup Flow

- 1 • Unzip the file downloaded to any location.
• Open the folder and double click the setup.exe.
- 2 The all-in-one installer starts and begins the setup wizard.
• Follow the wizard instructions and complete the printer setup. Here is the setup flow.

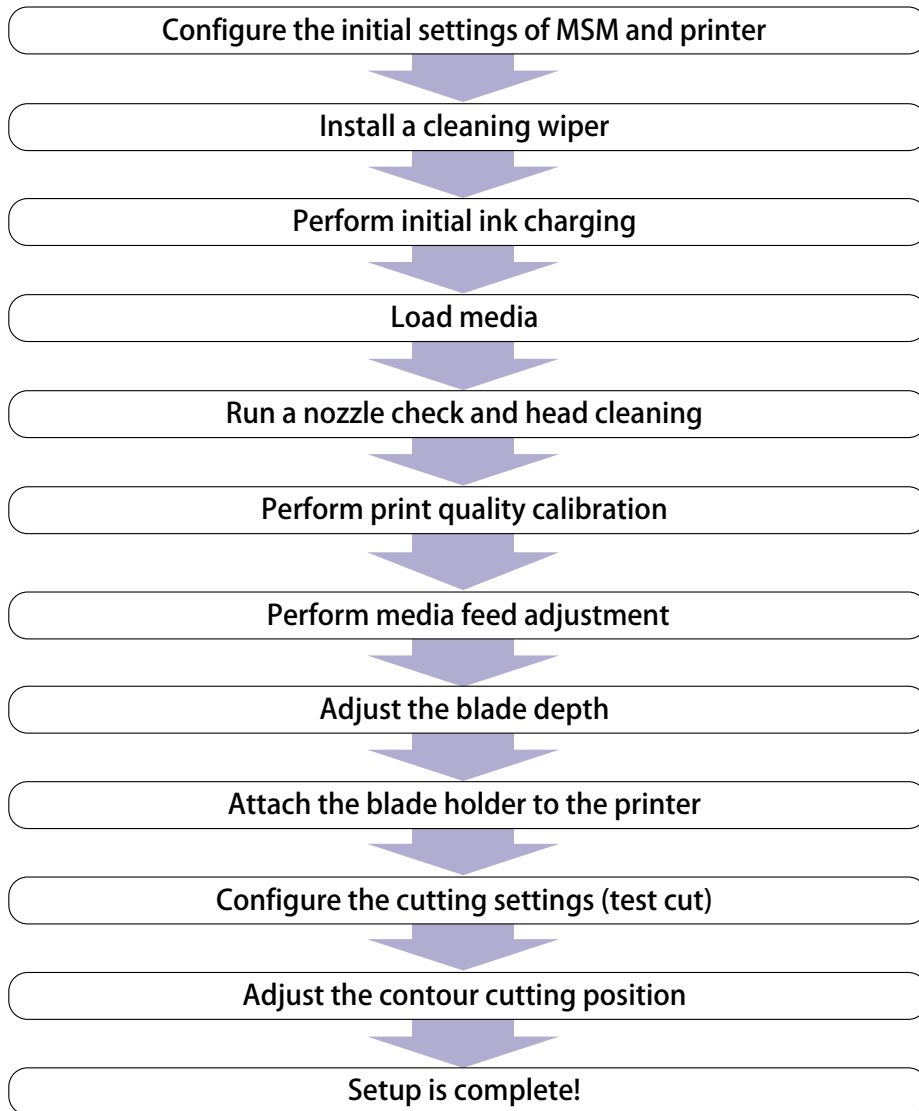

Configure initial setup of VerteLith and machine

You will need to configure the settings of printer, cutter and various print condition before outputting through VerteLith.

- 1 Start VerteLith and click [Add Printer].

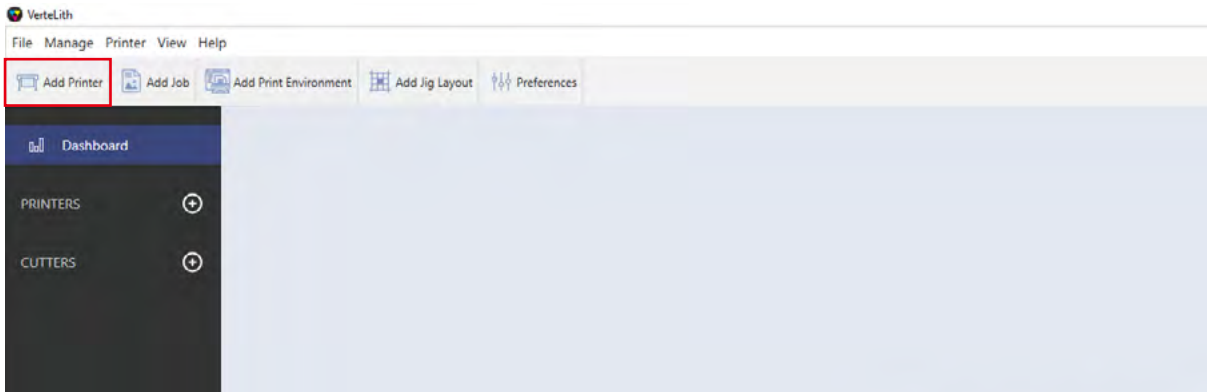

- 2 Configure access settings for MUTOH Club. Enter your user ID (e-mail address) and password, then click [Next].

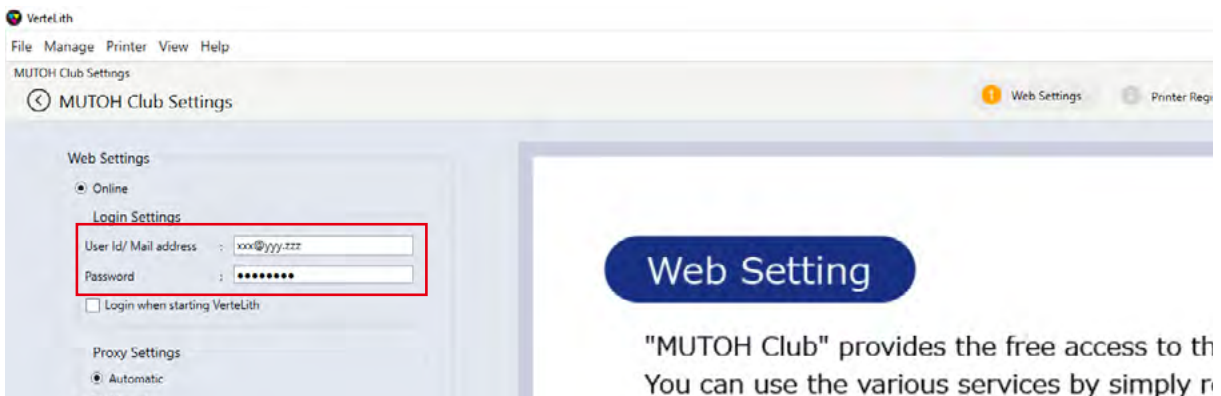

- 3 Enter the VerteLith serial number and authorization code, then click [Next].

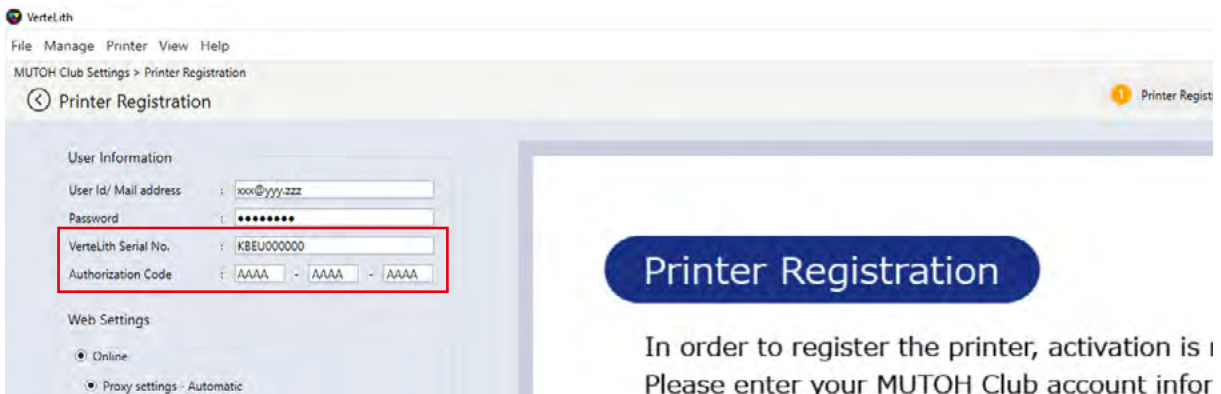

Check before installation

Unpacking

Assembling

Preparations

Setup

4 Select "Select from the printers on the network" and then click [Find Printer].

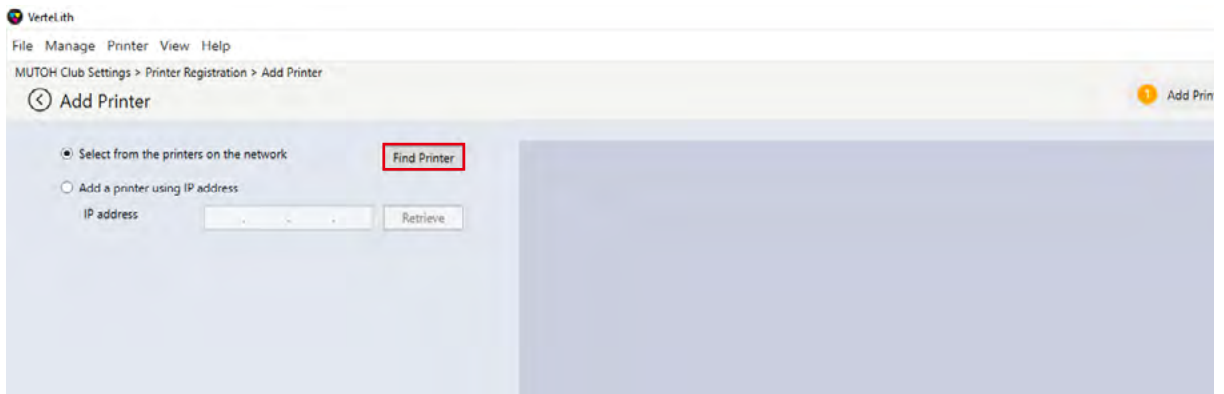

Important !

- Make sure that
 - the machine is connected to the network.
 - the machine is turned on.
- If the computer and this machine are connected on a different network, select "Add a printer using IP Address", enter the IP address of the printer, and click [Retrieve].

5 Select the machine you want to add and click [Next].

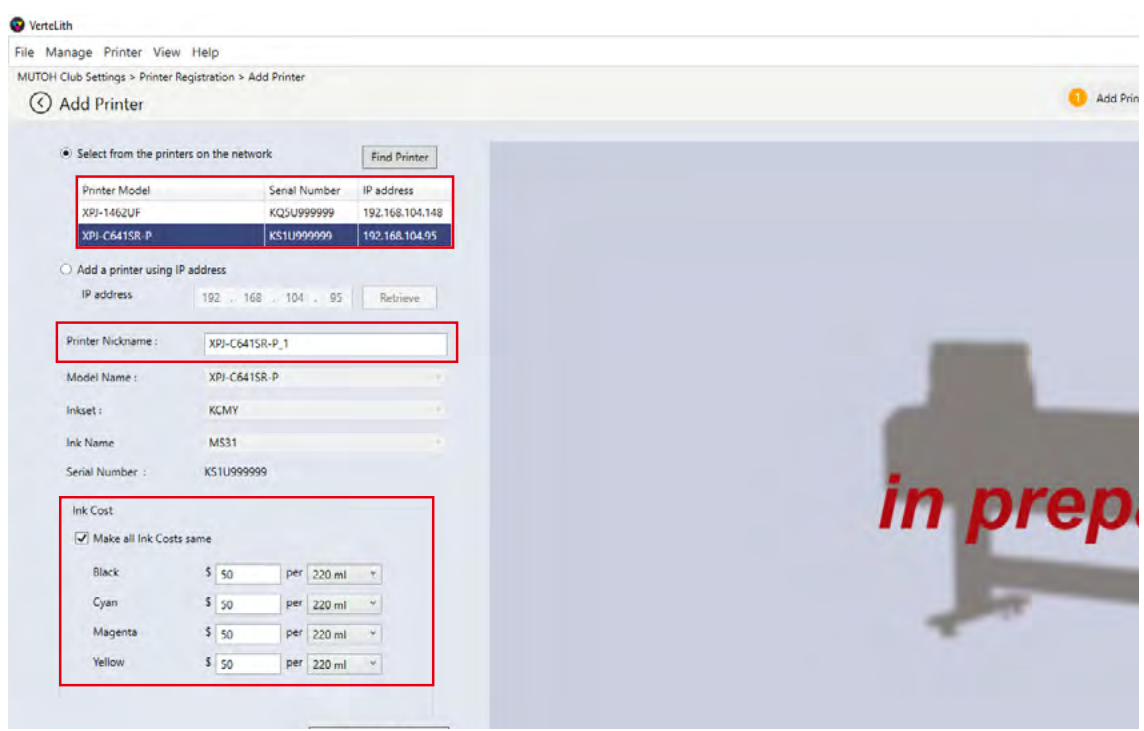

Note

You can change the name of the machine.
 By entering the unit cost of ink cartridges, the ink cost can be calculated.
 Both can be set up later.

6 Enter a name of the print environment and click [Next].

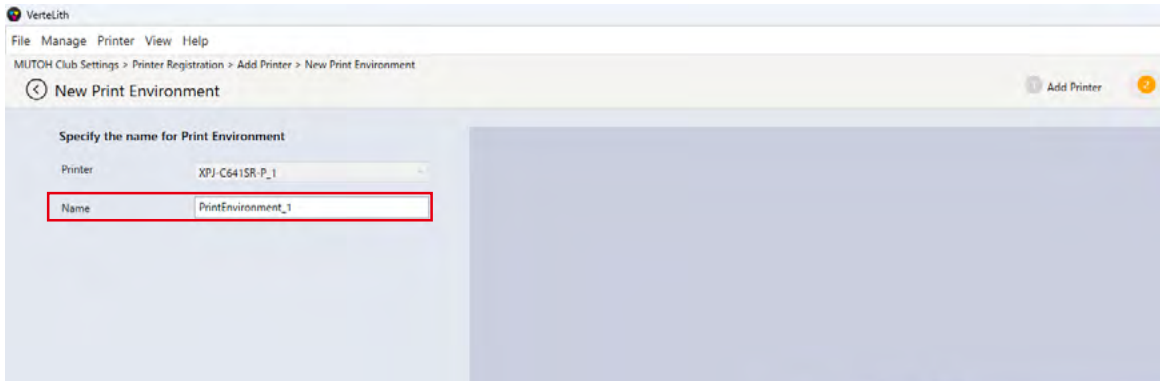

7 Specify the location of the hot folder. To change, click [Browse] to specify.

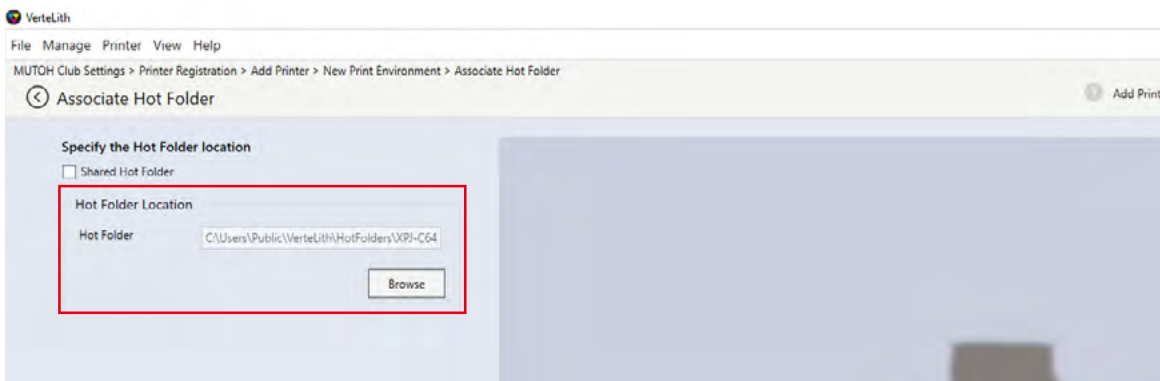

Important !

A hot folder is the folder that runs automatic processing on jobs.

The hot folder has two subfolders:

- Hold: You can add a job to VerteLith by copying or dragging the job to this folder.
- Print: You can print a job directly according to the print settings specified in the print environment by copying or dragging the job to this folder.

- 8** Specify the standard print settings for the print environment and click [Next].
- To edit the print settings, click [Edit].

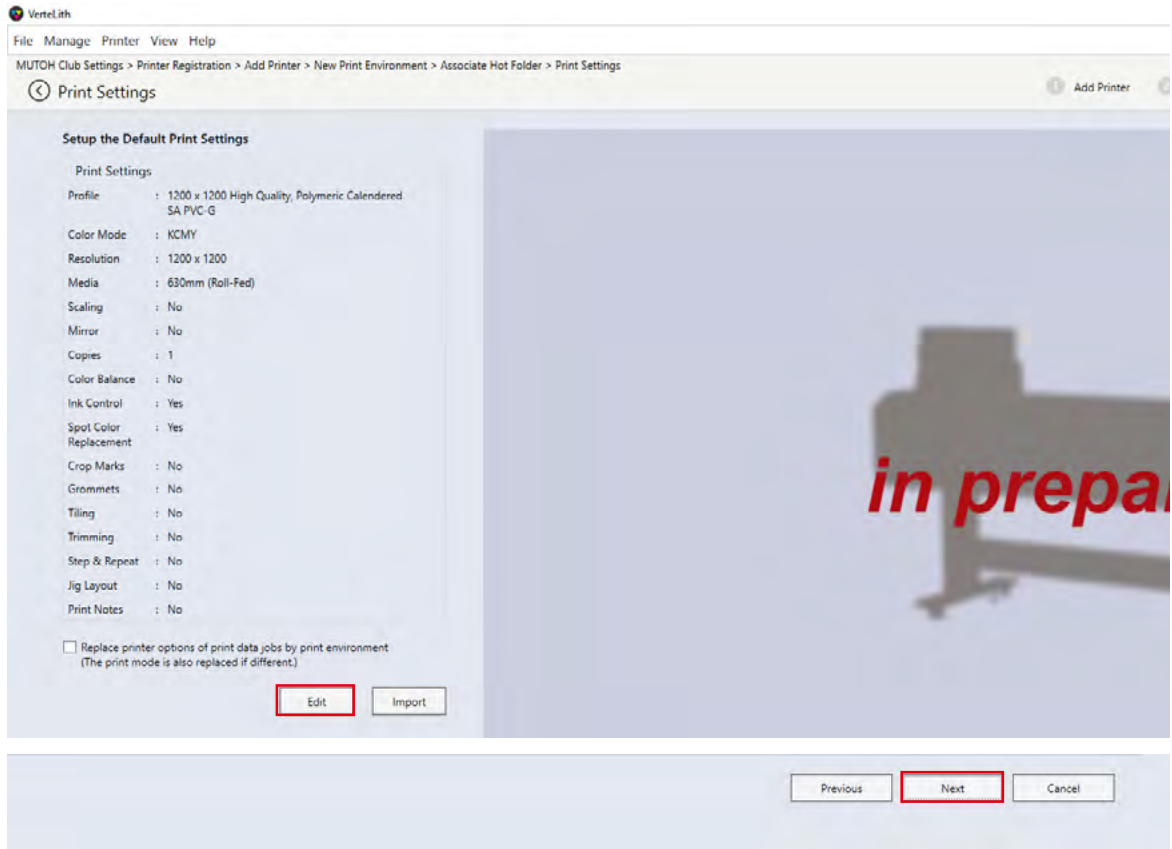

Important !
 These settings will be the default for a job added to the print environment.

- 9** If needed, select the “Allow Auto Nesting” checkbox and click [Next].

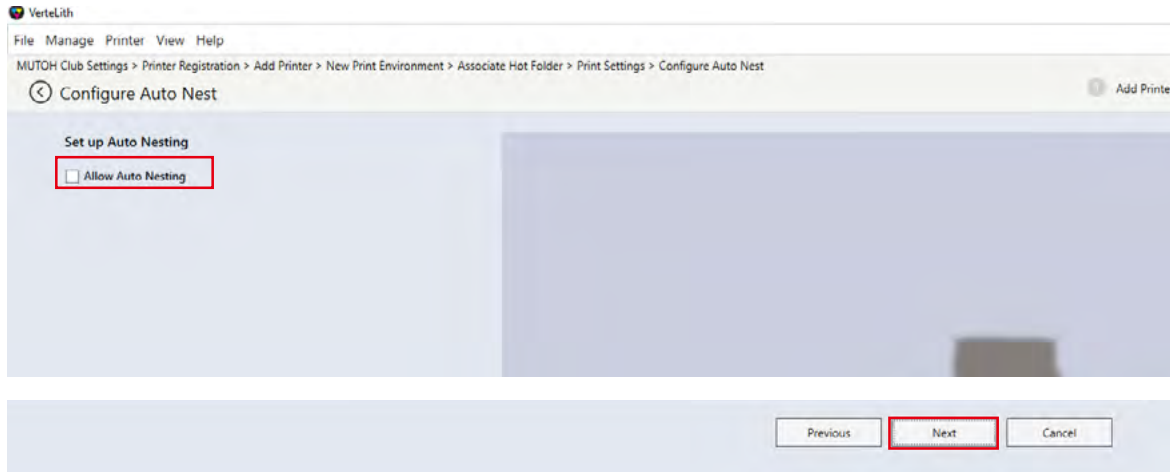

Important !
 By enabling auto nesting, jobs added to the print environment will be automatically nested with the specified conditions.

10 Click [Save].



11 The settings required for printing and cutting are now saved.

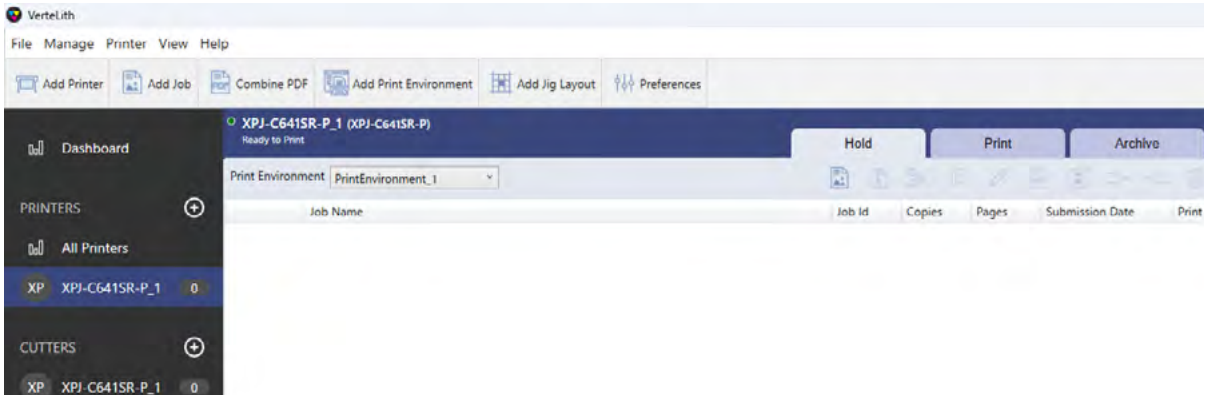

Check before installation

Unpacking

Assembling

Preparations

Setup

МУТОН